

4-1-1965

Special Libraries, April 1965

Special Libraries Association

Follow this and additional works at: https://scholarworks.sjsu.edu/sla_sl_1965

 Part of the [Cataloging and Metadata Commons](#), [Collection Development and Management Commons](#), [Information Literacy Commons](#), and the [Scholarly Communication Commons](#)

Recommended Citation

Special Libraries Association, "Special Libraries, April 1965" (1965). *Special Libraries, 1965*. 4.
https://scholarworks.sjsu.edu/sla_sl_1965/4

This Magazine is brought to you for free and open access by the Special Libraries, 1960s at SJSU ScholarWorks. It has been accepted for inclusion in Special Libraries, 1965 by an authorized administrator of SJSU ScholarWorks. For more information, please contact scholarworks@sjsu.edu.

SPECIAL LIBRARIES

APRIL 1965, VOL. 56, NO. 4

Proposed System for Organizing
Sound Recordings . . . 1964 Reprography
Bibliography . . . Library Searching
Flow Chart . . . URBANDOC Project . . .
SLA 1965 Convention Program

SPECIAL LIBRARIES ASSOCIATION

Putting Knowledge to Work

OFFICERS

- President
WILLIAM S. BUDINGTON
The John Crerar Library, Chicago, Illinois
- President-Elect
ALLEEN THOMPSON
General Electric Company, San Jose, California
- Advisory Council Chairman
LORNA M. DANIELLS
Harvard Business School, Boston, Massachusetts
- Advisory Council Chairman-Elect
HERBERT S. WHITE
NASA Facility, Documentation, Inc., Bethesda, Maryland
- Treasurer
JEAN E. FLEGAL
Union Carbide Corp., New York, New York
- Immediate Past-President
MRS. MILDRED H. BRODE
David Taylor Model Basin, Washington, D. C.

DIRECTORS

- WILLIAM K. BEATTY**
Northwestern University Medical School, Chicago, Illinois
- HELENE DECHIEF**
Canadian National Railways, Montreal, Quebec
- JOAN M. HUTCHINSON** (Secretary)
Research Center, Diamond Alkali Company, Painesville, Ohio
- KENNETH N. METCALF**
Henry Ford Museum and Greenfield Village, Dearborn, Michigan
- MRS. ELIZABETH B. ROTH**
Standard Oil Company of California, San Francisco, California
- MRS. DOROTHY B. SKAU**
Southern Regional Research Laboratory, U.S. Department of Agriculture, New Orleans, Louisiana

EXECUTIVE DIRECTOR: **BILL M. WOODS**
 Special Libraries Association, 31 East 10 Street, New York, New York 10003

MEMBERSHIP

Dues: Sustaining—\$100; Active—\$20 (Paid For Life—\$250); Associate—\$20; Affiliate—\$15; Student—\$2; Emeritus—\$5. For qualifications, privileges and further information, write Special Libraries Association.

THE 56TH CONVENTION WILL BE HELD AT
 BENJAMIN FRANKLIN HOTEL, PHILADELPHIA, PENNSYLVANIA. JUNE 6-10, 1965

PUBLICATIONS

| | | | |
|--|--------|---|----------------------------------|
| Aviation subject headings, 1949 | \$1.75 | National insurance organizations in the United States and Canada, 1957 | 3.50 |
| A checklist for the organization, operation and evaluation of a company library, 1960 | 2.00 | *Picture sources, 2nd ed., 1964 | 6.75 |
| Contributions toward a special library glossary, 2nd ed., 1950 | 1.25 | *SLA directory of members, as of July 15, 1964, 1964 | members 2.50 nonmembers 10.00 |
| Correlation index document series & PB reports, 1953 | 10.00 | SLA directory of members, as of October 15, 1962, 1962 | members 2.50 nonmembers 6.00 |
| Creation & development of an insurance library, rev. ed., 1949 | 2.00 | Source list of selected labor statistics, rev. ed., 1953 | 2.00 |
| Dictionary of report series codes, 1962 | 12.75 | Sources of commodity prices, 1960 | 5.00 |
| Directory of business and financial services, 1963 | 6.50 | Special Libraries Association personnel survey 1959, 1960 | 1.00 |
| Directory of special libraries, 1953 | 5.00 | *Special libraries: how to plan and equip them (SLA Monograph no. 2), 1963 | 5.55 |
| Guide to metallurgical information (SLA Bibliography no. 3), 1961 | 4.00 | Subject headings for aeronautical engineering libraries, 1949 | 4.00 |
| Guide to Russian reference and language aids (SLA Bibliography no. 4), 1962 | 4.25 | Subject headings for financial libraries, 1954 | 5.00 |
| Handbook of scientific and technical awards in the United States and Canada, 1900-1952, 1956 | 3.00 | *Subject headings in advertising, marketing, and communications media, 1964 | 5.95 |
| *Literature of executive management (SLA Bibliography no. 5), 1963 | 4.25 | Translators and translations: services and sources, 1959 | 2.50 |
| Map collections in the U. S. and Canada; a directory, 1954 | 3.00 | U.S. sources of petroleum and natural gas statistics, 1961 | 6.00 |

*Latest publications

SCIENTIFIC MEETINGS—Subscription, \$7.00; Foreign, \$8.00

SPECIAL LIBRARIES—Subscription, \$10.00; Foreign, \$11.00; Single copies, \$1.50

TECHNICAL BOOK REVIEW INDEX—Subscription, \$10.00; Foreign, \$11.00; Single copies, \$1.50

UNLISTED DRUGS—Subscription, \$20; Single Copies, \$2.00

SLA serves as the U.S. sales agent for selected Aslib publications

SPECIAL LIBRARIES is published by Special Libraries Association, monthly September to April, bimonthly May to August, at 73 Main Street, Brattleboro, Vermont 05302. Editorial Offices: 31 East 10th Street, New York, New York 10003. Second class postage paid at Brattleboro, Vermont.

POSTMASTER: Send Form 3579 to Special Libraries Association,
 31 East 10 St., New York, N. Y. 10003

The Faraday Press announces 23 major Soviet Scientific Journals now available for the first time

- **AUTHORITATIVE COVER-TO-COVER ENGLISH TRANSLATION**
- **REGULAR YEARLY SUBSCRIPTION - BEGINNING WITH JAN. 1965 ISSUES**

Cybernetics / *Kibernetika* Presents outstanding achievements by Soviet scientists and engineers in the theory of automata, self-organizing systems, the theory of games, network syntheses, perceptron theory and other vital areas. *Bi-monthly, \$115/year*

Problems of Information Transmission / *Problemy Pere-dachi Informatsii* Offers valuable Soviet contributions to information and coding theory, the detection of signals, machine modeling of the processes of information transmission, control systems, and other problems of cybernetics. *Quarterly, \$100/year*

Soviet Electrical Engineering / *Elektrotehnika* Consolidates in a single journal the most important research activities of Soviet electrical engineers; covers the design of electrical machines, generators, motors, switchgear, electric and magnetic circuits, power plant equipment, etc. *Monthly, \$160/year*

Magnetohydrodynamics / *Magnitnaya Dinamika Zhidkikh Metallov* A significant new quarterly devoted to theoretical and applied problems of plasma dynamics, magnetohydrodynamics of electrolytes, plastic flow of metals, magnetic control of heat transfer, the action of magnetic fields, and new MHD devices. *Quarterly, \$90/year*

Applied Solar Energy / *Geliotehnika* Reports the outstanding Soviet contributions in solar energy, and its many new, important applications, such as photochemical conversion, solar engines, distillation units, heat and power storage, etc. *Bi-monthly, \$110/year*

Theoretical and Experimental Chemistry / *Teoreticheskaya i Eksperimental'naya Khimiya* Describes the most important chemical research now in progress in leading chemistry research labs throughout the Soviet Union—the equivalent in importance in chemistry to the Soviet J. Theoretical & Exper. Phys. in Physics. *Bi-monthly, \$120/year*

Polymer Mechanics / *Mekhanika Polimerov* Latest Soviet research on the theory of polymerization and the physical and chemical properties of natural and synthetic polymers: plastics, elastomers, fibers, biopolymers, etc. *Bi-monthly, \$120/year*

Soviet Applied Mechanics / *Prikladnaya Mekhanika* Publishes advanced Soviet research in structural mechanics; special emphasis on the theory of plasticity, thermal stresses, stress concentrations, fatigue, vibration, and the design of thin shells. *Monthly, \$160/year*

Soviet Physics Journal / *Izvestiya VUZ. Fizika* Covers advanced Soviet theoretical and experimental investigations in plasma physics, optics, molecular physics, electronic processes and the entire range of physics research. *Bi-monthly, \$125/year*

Astrophysics / *Astrofizika* Describes Soviet research in lunar, interplanetary, solar and stellar physics, as performed under the direction of V. A. Ambartsumyan and other leading astrophysicists. *Quarterly, \$90/year*

Journal of Applied Mechanics and Technical Physics / *Zhurnal Prikladnoy Mekhaniki i Tekhnicheskoy Fiziki* A wide-ranging journal of importance to applied physicists, and mechanical, aeronautical, chemical, and structural engineers. *Bi-monthly, \$150/year*

Differential Equations / *Differentsial'nye Uravneniya* Offers for the first time in a single journal the original contributions of outstanding Soviet mathematicians to the theory of nonlinear and boundary-value problems and the numerical solution of differential equations. *Monthly, \$150/year*

Soviet Engineering Journal / *Inzhenernyy Zhurnal* Presents highly valuable contributions to the design of space vehicles, theoretical and experimental problems of mechanics, elastoplastic deformation, gas dynamics and aerodynamics. *Bi-monthly, \$150/year*

Journal of Applied Spectroscopy / *Zhurnal Prikladnoy Spektroskopii* Covers the physical fundamentals of spectroscopy, spectroscopic instrumentation and measuring techniques, luminescence phenomena, plasma diagnosis, the spectral properties of materials, and all of the more important applications of spectral analysis. *Monthly, \$150/year*

Mendeleev Chemistry Journal / *Zhurnal Vsesoiuznogo Khimicheskogo Ob-va im. Mendeleeva* Presents top-level conference proceedings and authoritative state-of-art papers in all the more important areas of organic chemistry, electrochemistry, biochemistry & pharmacology, and physical chemistry. *Bi-monthly, \$160/year*

Combustion, Explosion, and Shock Waves / *Nauchno-Tekhnicheskije Problemy Goreniya i Vzryva* A new quarterly in this fast-expanding field, devoted to theoretical and experimental studies of problems of combustion and detonation of gaseous mixtures, solid and liquid explosives, and the physical phenomena of shock waves. *Quarterly, \$100/year*

Chemistry of Heterocyclic Compounds / *Khimiya Geterotsiklicheskih Soyedineniy* Newest advances in the study of simple and condensed heterocyclic systems and their use as intermediates in the production of valuable new polymers, pigments, and drugs. *Bi-monthly, \$120/year*

Chemistry of Natural Compounds / *Khimiya Prirodnikh Soyedineniy* The Soviet journal devoted to original research into the isolation, structure, modification and synthesis of natural organic compounds. *Bi-monthly, \$110/year*

Applied Biochemistry and Microbiology / *Prikladnaya Biokhimiya i Mikrobiologiya* A new journal, publishing the results of basic and applied Soviet research in industrial and agricultural biochemistry and microbiology, including biochemical studies of proteins, nucleic acids, vitamins and hormones, and experimental investigations of microorganisms in the production of antibiotics, alcohol, fertilizers, enzymes, and other commercially interesting preparations. *Bi-monthly, \$120/year*

Physicochemical Properties of Materials / *Fiziko-Khimicheskaya Mekhanika Materialov* Describes extensive Soviet achievements in utilizing new materials in various working media at very high and low temperatures and pressures, and the technology of producing new materials capable of functioning under extreme conditions. *Bi-monthly, \$115/year*

Journal of Engineering Physics / *Inzhenerno-Fizicheskij Zhurnal* Devoted to Soviet basic and applied research in heat and mass transfer, exotic heat sources, hydrodynamics, thermo-physical properties, and gas dynamics. *Monthly, \$150/year*

Soviet Radiophysics / *Izvestiya VUZ. Radiofizika* Presents outstanding work by Troitskiy and other world-famous Soviet researchers in radioastronomy, quantum and statistical radiophysics, wave propagation, etc. *Bi-monthly, \$125/year*

Soviet Radio Engineering / *Izvestiya VUZ. Radiotekhnika* Publishes leading articles on Soviet advances in the design and construction of radio engineering equipment, HF electronics and electro-dynamics, information theory, and radio engineering measurements and instrumentation. *Bi-monthly, \$115/year*

Order your 1965 subscriptions to these essential Soviet journals from:



The Faraday Press
PUBLISHERS

15 Park Row, New York, N.Y. 10038

ATTENTION LIBRARIANS!!

Important Russian Instrumentation Journals

Available in Cover-to-Cover Translation

These four scientific and engineering journals have been judged by professionals in the instrumentation field to be the outstanding Soviet publications in instrumentation.

Automation and Remote Control

Monthly; mathematically oriented, emphasizing stability and optimization of automatic control systems.

Instruments and Experimental Techniques

Bi-monthly; devoted primarily to nuclear research and associated instrumentation.

Measurement Techniques

Monthly; covers measurement of physical variables plus test and calibration of measurement and recording instruments.

Industrial Laboratory

Monthly; devoted to methods of chemical analysis, physical investigation, and mechanical test.

| Subscriptions: | U.S. | Other Countries |
|-----------------------|-------------|------------------------|
| ARC | \$ 60.00 | \$ 80.00 |
| IET | 40.00 | 55.00 |
| MT | 25.00 | 35.00 |
| IL | 45.00 | 60.00 |
| Combination | \$153.00 | \$207.00 |

| | |
|---------------------|-----------------------------|
| Back Issues: | ARC: from 1957, except 1960 |
| | IET: from 1958, except 1961 |
| | MT: from 1958 |
| | IL: from 1958 |

Complete volumes of back issues will be sold at the same price as current volumes.

Sample copies are available to librarians writing on organizational letterhead.



Instrument Society of America, Department R2
530 William Penn Place, Pittsburgh, Pennsylvania 15219

Coming in June... your master key to all the news of '64

Place your order **now** for the 1964 annual volume of The New York Times Index... an indispensable reference work for libraries of every kind serving every informational need.

- It's packed with basic news in-

CURRENCY. See Counterfeiting. Geog heads (subdiv Econ where subdivided) (for foreign investments and assets). Commodity and indus names. For role in internat trade, see Commerce. Note: For 2 or more countries, see subhead which comes first alphabetically

Canada. Mint expects huge demand for '65 "prooflike" sets; limits orders to 5; raises price to \$4. D 20,II,31:5

Cyprus. Draws \$1.95 million from IMF. D 16, 67:1

Germany, West. Jan-Oct payments deficit \$550 million against \$300-million surplus, '63 period. D 31,35:5

Great Britain

Bank of Eng details pound crisis, qtrly bulletin, 63:3; dipped into reserves to support pound, 17,63:2; rest...

formation on everything under the sun that happened in 1964.

- It's easy to use — fully organized, alphabetized, cross-indexed.
- It summarizes the facts of every news story.
- It gives you the exact date and location of the full story in The New York Times.
- It helps you track down stories in other newspapers and news magazines.

The cost? Just \$60 a copy—and it's well worth it in the research time and effort it saves you. Add \$45 more and we'll also send you the semimonthly issues of the Index for an entire year. (If ordered separately, they would cost \$60.)

Why not plan now to enjoy the **complete** Index service in the year ahead? Your order will receive our immediate attention.

The New York Times Index
Times Square, New York, N. Y. 10036

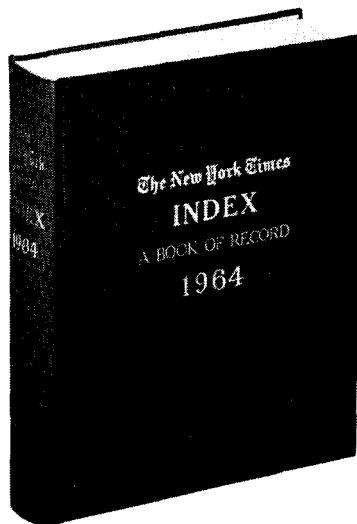

New Publications from Western Periodicals Co.

Society for Information Display

Fifth National Symposium—Feb. 25-26, 1965—Santa Monica, Calif. \$10.00
Fourth National Symposium—Oct. 1-2, 1964—Washington, D. C. \$10.00
Also available: Third and Second National Symposia—\$10.00 each
First Symposium—Microfiche \$4.00 Duopage \$16.00

IEEE Conventions on Military Electronics

Volume 4—1965—\$15.00 Volume 3—1964—\$10.00 Volume 2—1963—\$10.00
Volume 1—1962—\$10.00

Journal Of Astronautical Sciences

Volume 1-10 (1954-1963) \$125.00
Bound in partial reprint—separately available
Vols. 1-2 bound (1954-1955)—\$30.00 Vols. 3-5 bound (1956-1958)—\$45.00
Vols. 6-8 bound (1959-1961)—\$45.00 Vols. 9-10 bound (1962-1963)—\$30.00

Exclusive Distributor:

WESTERN PERIODICALS CO.

13000 Raymer St.

North Hollywood, California

TRiangle 5-0555

WHERE ?????

“too recent for abstracts

. . . and too specific in any case
for easy finding. . . .”

BRITISH TECHNOLOGY INDEX

Pinpoints target subjects

Current subject guide to 400 British technical journals

Invaluable for current awareness and for keeping marginal
interest subjects in sight

Complete service (12 monthly Parts & Annual Volume) \$50

Annual Volume \$30

LIBRARY ASSOCIATION, CHAUCER HOUSE, MALET PLACE,
LONDON W.C. 1. ENGLAND

SPECIAL LIBRARIES

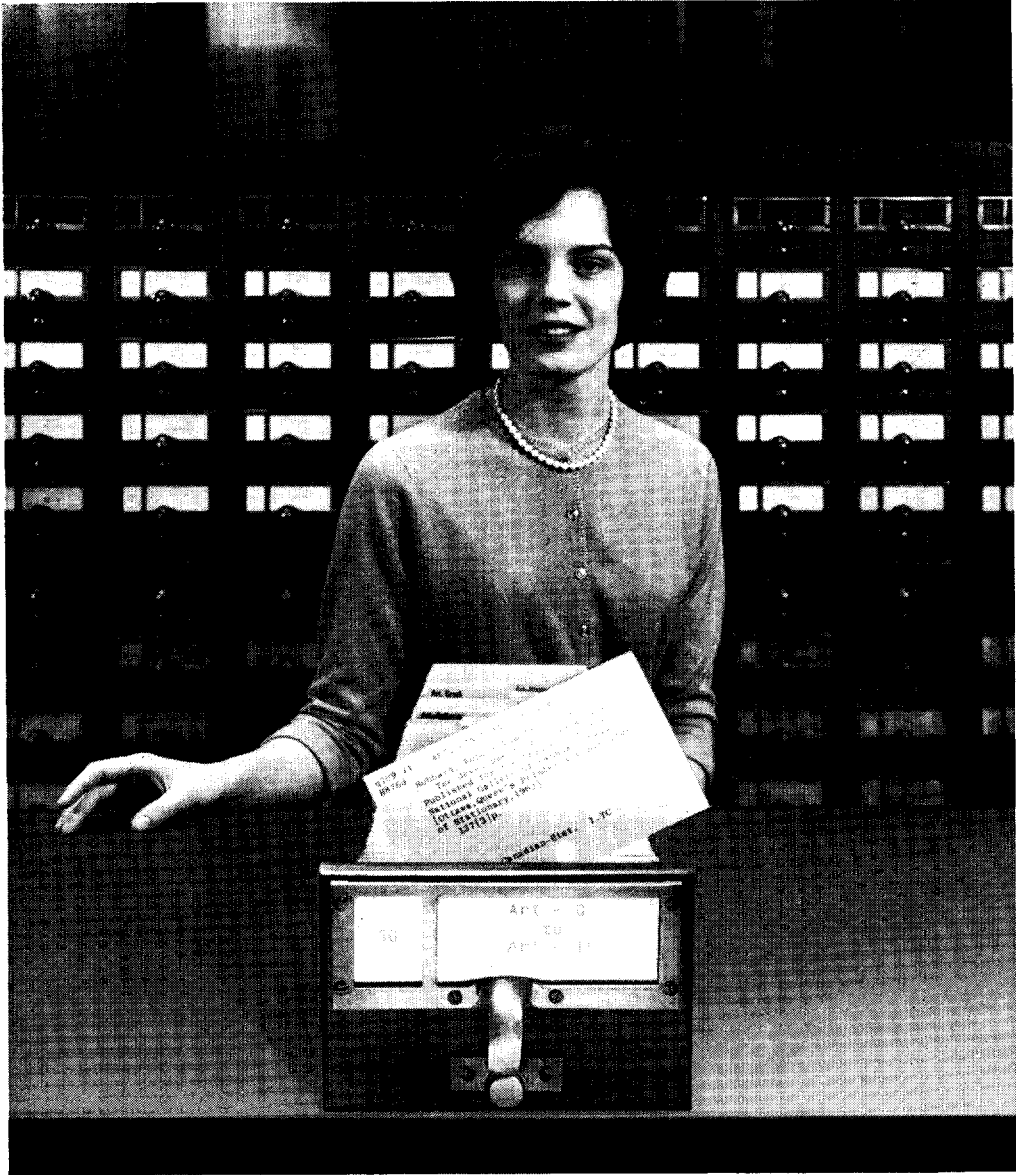

we'll duplicate all your catalog cards...

... and return them to you within 72 hours. Any number of duplicate catalog cards, copied photo-exact from your original. Same size, durable, top-grade stock, precision-punched and trimmed, returned to you in the same order as the file you submit... Samples and prices on request; special mailers and in-

structions for your convenience... Xerox branch offices in principal U.S. and Canadian cities. Call the one nearest you—or write Xerox Corporation, Rochester, New York 14603. In Canada, Xerox of Canada Limited, Toronto.

XEROX

NEW ENLARGED

1965 Out-Of-Print Books
Catalog Now Available

Lists over 5,000 Titles

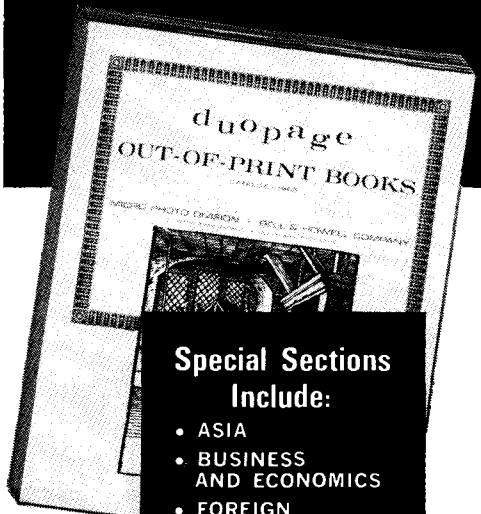

Special Sections Include:

- ASIA
- BUSINESS
AND ECONOMICS
- FOREIGN
LANGUAGE BOOKS
- GENEALOGY
- MATHEMATICS
- RELIGION
- RUSSIA
- U. S. HISTORY

Send for your free copy...

Micro Photo Division
BELL & HOWELL COMPANY

1700 SHAW AVENUE
CLEVELAND, OHIO 44112

Aslib Publications Available from SLA

Faceted Classification

B. C. Vickery 1961 \$1.74

Survey of Information/Library Units in Industrial and Commercial Organizations

Campbell and Hanson 1960 \$1.74

The Foreign Language Barrier

C. W. Hanson 1962 \$1.68

Handbook of Special Librarianship, 2nd ed.

W. Ashworth 1962 \$8.82

Film Cataloguing Rules 1963 \$4.14

Index to Theses Accepted for Higher Degrees in the Universities of Great Britain and Ireland

Vol. 10 1959-60 \$3.50

Vol. 11 1960-61 \$3.50

Vol. 12 1961-62 \$3.50

Aslib Directory, 2 vols. 1957 \$17.58

Amendment No. 1, 1960-61 Free
with above

Report of an Investigation of Litera- ture Searching by Research Scien- tists

John Martyn 1964 \$1.04

Technical Libraries: Users and Their Demands

Margaret Slater 1964 \$3.64

Looking Forward in Documentation

1964 \$2.52

Special Libraries Association

31 East 10th Street, New York 10003

READER APPEAL

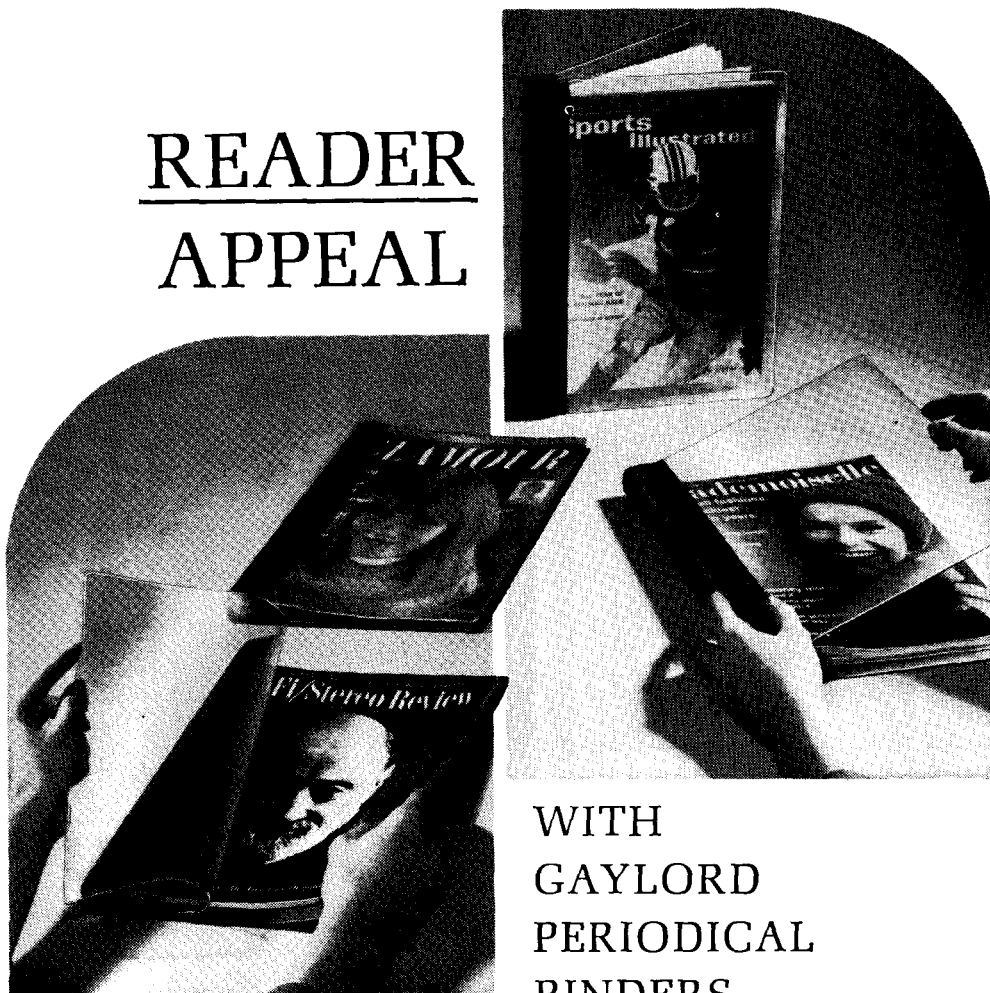

WITH
GAYLORD
PERIODICAL
BINDERS

PAT. 3,151,886

Periodicals look more inviting, stay cleaner, last longer, when you display them in Gaylord Periodical Binders. Attractively styled with either flexible or rigid covers, these binders will protect and prolong the life of even your most popular magazines.

Series 680 has flexible covers, the front transparent, back opaque. Series 780 has rigid, transparent covers front and back. Each is available in eight popular sizes and two colors, sable brown or apple red. Both series feature a quick acting hidden lock and stainless steel compression springs which automatically accommodate thick or thin periodicals.

Add reader appeal to your periodicals. Send for complete information on Series 680 and 780. Prices from \$2.85.

Gaylord Bros., Inc. 

SYRACUSE, N. Y. STOCKTON, CALIF.

LIBRARY SUPPLIES

CLEAN ROOMS . . . WHITE ROOMS

If your company designs, manufactures or sells any contaminant-sensitive products or materials . . . your library needs this comprehensive text!

DESIGN & OPERATION of CLEAN ROOMS

by Philip R. Austin
370 Illustrations

•
•

Stewart W. Timmerman
14 Chapters

The book covers all phases of contamination control. It provides an introduction to clean rooms and the history of contamination control. Particulate matter, filtration, product requirements and clean room design are each discussed in separate chapters. Other chapters include laminar flow design and monitoring of clean rooms, garments and their requirements, parts cleaning, standards of air cleanliness and much more. Illustrations and photographs clearly depict each subject in this latest and most complete book ever written on clean room applications.

If your firm is in the aerospace, electronics, optics, photography, pharmaceuticals, micro-miniaturization, hospital, food or any one of a number of similar industries dealing with contaminant-sensitive products or materials, this book can be a valuable addition to your library. 440 Pages—\$25.00

Order your copy for a 10-Day Free Examination. Write today to:

Business News Publishing Company
450 W. Fort Street
Detroit, Michigan 48226

MEDICAL LIBRARY ASSOCIATION PUBLICATIONS

Serials:

VITAL NOTES ON MEDICAL PERIODICALS \$ 5.00 year

Records births, deaths, and title changes
3 times a year

BULLETIN OF THE MEDICAL LIBRARY ASSOCIATION \$12.00 year
Articles of interest to all librarians (single nos. \$3.50)
4 times a year

Monographs:

DEVELOPMENT OF MEDICAL BIBLIOGRAPHY \$ 5.00

by Estelle Brodman. 1954
An important contribution in the history of
science bibliography

HANDBOOK OF MEDICAL LIBRARY PRACTICE \$10.00

edited by Janet Doe. 2d ed. Chicago,
American Library Association. 1956
Discusses problems common to all libraries

Indexes:

BULLETIN OF THE MEDICAL LIBRARY ASSOCIATION

v. 1-40, 1911-1952 \$ 3.50

v. 41-50, 1953-1962 \$ 2.00

MEDICAL LIBRARY ASSOCIATION

919 North Michigan Avenue, Chicago, Illinois 60611

SPECIAL LIBRARIES



Can you read those characters?
 She can! It's part of her job.
 It's our job too. In any tongue,
 on any subject.

- AUTOMATION AND SYSTEMS DESIGN
- CONSULTING AND PLANNING
- CUSTOMIZED CATALOGING
- WORLD-WIDE ACQUISITIONS
- BIBLIOGRAPHIC AND SPECIAL SERVICES
- INDEXING AND ABSTRACTING

Translation: "Library service is our business"

JOHN I. THOMPSON & COMPANY

Phone 202 - 337-4200

1118 22nd Street, N. W., Washington, D. C., 20037

APRIL 1965

Please send detailed information:

Firm: _____

Attention: _____

Address: _____

*Library Sciences Division
 John I. Thompson & Company*

**Don't miss our exhibit
 at the SLA Convention • Booth 89**

Now Ready! The New 516-page Edition of THE 1965 AB BOOKMAN'S YEARBOOK

THE SPECIALIST BOOK TRADE ANNUAL—FOR ALL BOOKMEN:
DEALERS AND PUBLISHERS, LIBRARIANS AND COLLECTORS

Contents

The Old & The New

PART I AB REFERENCES

Editor's Corner
Specialist Booksellers
Specialist Book Publishers
Specialist Book Services
AB Index of Display Advertisers
AB Subscription Form & Rate Chart

SEPARATE PART II AB FEATURES

THE SPECIALIST BOOK TRADE

Autographs—1965—An Appraisal
Mary A. Benjamin
Miniature Books—*Louis W. Bondy*
Dime Novel Collecting—*Charles Bragin*
Modern Firsts—*Marguerite A. Cohn*
Modern Trends in Modern Collecting
Philip C. Duschnes
Western Americana Collecting
Charles Eberstadt
Generations of Genealogy
John W. Farquharson
Lucky Finds—*W. R. Fletcher*
World of Africana—*Walter Goldwater*
Americana Collecting Trends
William F. Kelleher

Appraisal of Literary Properties
Robert F. Metzdorf

Hurrah for Ephemera—*Arthur H. Minters*
Children's Books for Millionaires—*P. H. Muir*
Music Collecting—*S. Orlinick*
Mapping the Future—*Kenneth Nebenzahl*
Renaissance and Reformation
Leona Rostenberg
Modern First Editions—*Bertram Rota*
Aeronautics—Flying High—*Edward L. Sterne*
Collecting Manuscripts Today
Alan G. Thomas
American Literature—*John S. Van E. Kohn*
Future of Occultism—*Donald Weiser*
My Fair Lady—*Elisabeth Woodburn*
Early American Science—*Richard S. Wormser*

THE O. P. MARKET: 1965

(Reference Directory of Specialist and Anti-
quarian Booksellers)

TRADE SERVICES DIRECTORY: 1965

(Reference Guide to Trade Services for Spe-
cialist Book World)

Permanent Book Wants
Antiquarian Book Exchange



BOOKMAN'S YEARBOOK: The Specialist Book Trade Annual is published in the U.S.A. by
ANTIQUARIAN BOOKMAN: The Specialist Book Trade Weekly, Box 1100, Newark 1, N. J.
AB Yearbook \$5 (Part I \$3, Part II \$2) net, cwo, postpaid. L.C. Catalog Card #54-1676
World Copyright 1965 © by Sol. M. Malkin, Editor and Publisher, AB Weekly and AB Yearbook.
Associate Publisher Mary Ann O'Brian Malkin. [Subscription form & rate chart, pages 364-367]

SPECIAL LIMITED OFFER: Bookmen interested in keeping up with this fast-growing spe-
cialist book field can subscribe to AB Weekly (\$12.50 a year, U.S., Canadian & Foreign) and re-
ceive a FREE copy of "THE 1965 AB BOOKMAN'S YEARBOOK." *Supply is limited.*

Send in your subscription and get your Free Copy Now of "THE 1965 AB"! Try AB! 25¢ a week!

SPECIAL LIBRARIES

A "PLAN-AHEAD" calendar for your ordering department . . . showing the full schedule for reprinting all back volumes of

THE NEW YORK TIMES ANNUAL INDEX - -

from 1851 thru 1961

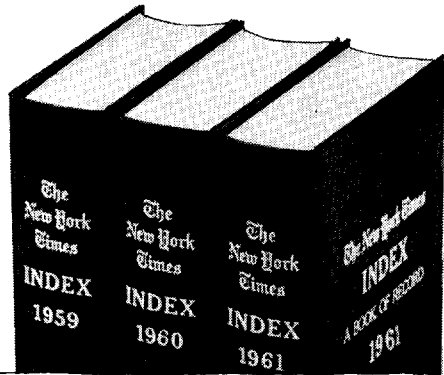

| | | |
|---|---|---|
| <p>NOW READY</p> <p>1930-61</p> <p>Annual Indexes, with some years in 2 volumes, others in 1; \$44.50 net pp. per ANNUAL INDEX.</p> | <p>Coming JUNE, 1965</p> <p>1920-29</p> <p>Annual Indexes, with each year in 2 volumes; \$44.50 net pp. per ANNUAL INDEX.</p> | <p>Coming NOVEMBER, 1965</p> <p>1913-19</p> <p>Annual Indexes, with each year in 2 volumes; \$44.50 net pp. per ANNUAL INDEX.</p> |
| <p>Coming SPRING, 1966</p> <p>1863-1904</p> <p>Annual Indexes: these will be priced at \$44.50 net pp. per volume, with several years in each volume, as follows: 1863-74, 1875-80, 1881-86, 1887-90, 1891-93, 1894-98, 1899-1904.</p> | <p>Coming SUMMER, 1966</p> <p>1851-62</p> <p>Annual Indexes: these 12 years will appear in a single volume at \$44.50 net pp. The 1851-1858 portion will be reproduced in its original handwritten form. The remaining years have never been available before and are now being compiled for the first time.</p> | <p>Coming FALL, 1966</p> <p>1905-12</p> <p>Annual Indexes: these will appear in 2 volumes — 1905-08 in one volume at \$44.50 net pp. and 1909-12 in another at \$44.50 net pp. NOTE: These INDEXES have never been available before and are now being compiled for the first time.</p> |

You can order any or all back volumes of THE NEW YORK TIMES ANNUAL INDEX right now — to be delivered to you as shown on the above calendar. This publication forecast is tentative, of course, but should be valuable to you in arranging your future budgets to get the volumes you need. For further details on deferred payment or any other arrangements we might make to help solve your budget problems, please write.

B **R. R. BOWKER COMPANY,** 1180 Avenue of the Americas, New York, N.Y. 10036

BRITISH MEDICAL JOURNAL



Read the best British journal for complete coverage of research in medical science and trends in clinical medicine throughout the world.

Published weekly.

Annual Subscription \$15.00.

The British Medical Journal publishes also a number of specialist journals the following of which are listed below for your particular attention.

- **BRITISH HEART JOURNAL.** The Official Journal of the British Cardiac Society. Covers all aspects of cardiology, including anatomy, physiology, and pathology. One of the foremost cardiological journals in the English language. *Annual Subscription (six issues a year), \$14.00.*
- **GUT.** The Journal of the British Society of Gastroenterology. Covers the whole field of gastroenterology—alimentary, hepatic and pancreatic disease and papers may cover the medical, surgical, radiological or pathological aspects. *Annual Subscription (six issues a year), \$14.00.*
- **JOURNAL OF CLINICAL PATHOLOGY.** The Journal of the Association of Clinical Pathologists. Publishes specially commissioned articles on each branch of pathology with prominence given to its clinical application. Technical methods; notes on new or improved apparatus; book reviews. *Annual Subscription (six issues a year), \$14.00.*
- **THORAX.** The Official Journal of the Thoracic Society. Publishes original work on diseases of the chest relevant anatomical and physiological studies by authors in Great Britain and many other countries. *Annual Subscription (six issues a year), \$14.00.*
- **JOURNAL OF MEDICAL GENETICS.** A new journal publishing articles on clinical, statistical, pathological, cytological and bio-chemical aspects of medical genetics. *Published Quarterly. Annual Subscription \$10.00.*
- **BRITISH JOURNAL OF INDUSTRIAL MEDICINE.** Authoritative papers on all aspects of occupational medicine, e.g. the pneumoconioses, occupational cancers, industrial toxicology and psychology. *Published Quarterly. Annual Subscription \$10.00.*
- **BRITISH JOURNAL OF VENEREAL DISEASES** fulfils the need for a journal devoted entirely to the world-wide problem of the treatment and control of venereal diseases. Its subject matter is contributed by authors throughout the world. *Published Quarterly. Annual Subscription \$10.00.*

- **ABSTRACTS OF WORLD MEDICINE.** This journal provides critical abstracts selected from 1,500 of the world's leading medical journals. In addition the 'ABSTRACTS' publishes a series of *Review Articles*. Published from time to time, each will deal with one of the 'growing points' of medicine.

Published monthly.

Annual Subscription \$18.00.

These famous journals should be included in every medical library.

ORDER YOUR SUBSCRIPTION NOW

Subscription orders only:
BRITISH MEDICAL JOURNAL
80 Brighton Avenue,
Boston, Mass. 02134

All enquiries to The Publisher,
BRITISH MEDICAL JOURNAL
B.M.A. House, Tavistock Square,
London, W.C.1, England.

SPECIAL LIBRARIES

Official Journal
Special Libraries Association

Volume 56, No. 4

CONTENTS

April 1965

| | | |
|---|-------------------------------------|----------|
| A Proposed Information Retrieval System for Sound Recordings | C. B. HAGEN | 223 |
| Bibliography on Reproduction of Documentary Information January-December 1964 | LORETTA J. KIERSKY | 229 |
| Flow Chart on Library Searching Techniques | SALLY SWENSON | 239 |
| Is This a Problem? | LOUISE STOOPS | 243 |
| URBANDOC: A Cooperative Project of Librarians and Planners | HOWARD BENTLEY AND RICHARD MAY, JR. | 244 |
| SPECIAL LIBRARIES ASSOCIATION | | |
| Join the Ranks of NLW Promoters! | | 246 |
| 56th SLA Convention Program | | 249 |
| SLA Sustaining Members | | 259 |
| 1965 SLA Annual Meeting | | 260 |
| SLA Hall of Fame 1965 | | 264 |
| NEWS | | |
| Vickery Leads Seminar on Faceted Classification | | 228 |
| Spotted | | 242 |
| Rebecca B. Rankin: In Memoriam | JAMES KATSAROS | 248 |
| Have You Heard | | 238, 265 |
| Off the Press | | 267 |

Editor: MARY L. ALLISON
Assistant Editor: EDYTHE C. PORPA

SPECIAL LIBRARIES COMMITTEE
Chairman: ROBERT G. KRUPP
HOWARD B. BENTLEY
MRS. ELIZABETH R. USHER

Papers published in SPECIAL LIBRARIES express the views of the authors and do not represent the opinion or the policy of the editorial staff or the publisher. Manuscripts submitted for publication must be typed double space on only one side of paper and mailed to the editor. ● Reprints may be ordered immediately before or after publication. ● Subscriptions: U. S. \$10; foreign, \$11; single copies, \$1.50. © by Special Libraries Association 1965.

INDEXED IN *Business Periodicals Index, Public Affairs Information Service, Library Literature, Management Index and Library Science Abstracts.*

University Microfilms puts 75,000 Doctoral Dissertations at your fingertips.

*Now you can offer a complete reference library
of the research that's being done at most
of the leading universities and colleges in the country.*

Every month, University Microfilms publishes *Dissertation Abstracts*. This publication contains abstracts of every dissertation received monthly from 150 colleges and universities.

These abstracts are written by the candidates. They cover mathematics, sciences, social sciences, and the humanities. They are indexed by expert cataloguers from the Library of Congress.

All in all, we've published more than 75,000 abstracts in the past twenty-seven years. All of the back issues are available in bound volumes at a special price. You can subscribe to the current issues of *Dissertation Abstracts* for \$70.00 a year.

We can also give you a complete copy of any dissertation listed in *Dissertation Abstracts*. You have your choice of either microfilm or hard copy. Positive microfilm will cost you about 1¼ cents a page. Or you can get a xerographic copy of the original for about 4½ cents a page.

To start your subscription, or for more information about this service, simply fill out the coupon and mail it to us.

- Please start our subscription to **Dissertation Abstracts**.
- Please send additional information.

NAME _____

ADDRESS _____

CITY _____ STATE _____

 **UNIVERSITY MICROFILMS, INC.**
313 NORTH FIRST STREET, ANN ARBOR, MICHIGAN
A subsidiary of Xerox Corporation.

A Proposed Information Retrieval System for Sound Recordings

C. B. HAGEN

IN MY CAPACITY as a sound engineer and librarian, I have begun at Mount St. Mary's College in Los Angeles, a project of preserving on magnetic tape important lectures, speeches, TV and radio documentaries, important newscasts, drama and theater productions, live broadcasts of local concerts and recitals, broadcasts of international music festivals, phonograph records no longer available, and other material that cannot be normally obtained on commercial recordings. This project parallels the College's program of acquiring commercial recordings, both on records and on tape. There are technical and legal* considerations, interesting problems of circulation and use, and so on, but this paper deals only with the information retrieval aspects.

It is immediately apparent that a system embracing such a heterogeneous collection of recordings has to be extremely flexible. The system proposed here has been designed with this goal in mind, but it can also be applied to much smaller collections, even those of the average individual collector.

Accessioning and Indexing

Each individual piece of recorded material (musical compositions, separate radio programs, a newscast, etc.) is assigned a se-

* Regarding legal and copyright aspects the author has prepared a report on the subject entitled A Report to the U.S. Copyright Office on the Library, Educational and Private Uses of Recordings. A condensed version of this report has been recently published: Copyright and the Threat to Fair Use of Sound Recordings, *NAEB Journal*, January-February 1965, p. 43-71.

The author is Head of the Map Library at the University of California at Los Angeles. In private life, Mr. Hagen owns and operates a recording studio, and the project he describes here is based on his experiences with these facilities. He has undertaken this project on a voluntary non-profit basis, with all the costs of recording, except blank tape, being donated to Mount St. Mary's College.

quential accession number. A given storage unit, such as a phonograph record or a reel of tape, is identified by limiting accession numbers, e.g. Reel 735-739.

For most commercial records or tapes the label, jacket, or box satisfactorily identifies and describes the item. For non-commercial recordings, however, a brief description has to be prepared. Ideally at the time a tape is made the recording engineer prepares for each reel an index sheet with brief descriptions of each item recorded, giving data such as composer, title, performing artists, source, date, speed used, and so on. When available, the printed programs of events or broadcasts can be clipped and pasted onto the index sheet, with the engineer adding date, speed used, length, and other information. Duplicate copies of these index sheets can gradually become a sort of master index that can be arranged by accession numbers and kept in a separate place.

After recording and indexing the problem of cataloging has to be faced. It is in this area where I feel a very serious situation exists because of the prevailing feelings among librarians that special materials can be treated very much like books. In the case of recorded materials the immense complexity and impracticality of trying to adjust standard book cataloging rules to recordings is staggering. If standard rules are applied, in the large majority of the cases, the cost of cataloging will be much higher than the cost of the items cataloged and a highly specialized staff will be needed. A dramatic example of this situation was reported some years ago when the public library of a Mid-



western city decided to fully catalog and maintain its relatively moderate record library according to all the existing rules. This decision meant that the entire work output of eight full-time employees—three catalogers, three skilled helpers, and two clerical workers—was devoted to the project. The startling fact that about as many personnel were engaged in cataloging recordings as were usually employed cataloging books became evident. It is pertinent at this point to remember a statement made more than 20 years ago by Archibald McLeisch, then Librarian of the Congress:

The profession . . . candidly face the fact that present cataloging methods are nineteenth century methods devised for forms of print which no longer constitute the bulk of library accessions, and for categories of readers who constitute a part only of present and potential library clientele.¹

This statement becomes especially prophetic in view of the enormous advances of modern technology. New and improved magnetic tape recording techniques, for instance, have reduced speeds and increased trackings, flooding the markets with thousands of previously unavailable or unknown works and reducing costs from a few dollars to a few cents. The very complex and meticulous cataloging rules now in existence for this type of material create an immense gap between labor costs and material costs. Faced with such a situation many record and tape libraries have been forced to reject or to substantially modify the standard rules; as a result, a number of isolated and often awkward systems of classification and cataloging have been created with each system geared to the peculiar problems, staff, and holdings of its own collection and, unfortunately, with great variations in quality and efficiency.

The Library of Recorded Sound at Mount St. Mary's College collects a wide variety of materials, containing all types of materials of a conventional record or tape library plus many others. The present tendency in collections of recorded sound is precisely in this

direction of a wide variety of types of materials. After a survey of its present and future development and service patterns, we have concluded that a cataloging system suited for this or similar collections should meet the following requirements:

1. The cost of cataloging should be lower than the cost of most of the items cataloged. At present the average cost of most of the individual items ranges from 20 to 80 cents. In terms of labor at the present rates for skilled technical library help (about \$2 per hour) this means that 10 to 25 minutes might be spent cataloging an item. Average cataloging time, therefore, should not be more than 15 minutes per recorded item.
2. The process should be simple enough to be handled by skilled non-professional help. In our case, as in many of other music libraries of this type, the only labor available is student help.
3. The system should be simple and uniform enough as to withstand the high turnover of a college library operating mostly with student help.

The cards described in the system discussed below are basically catalog cards adapted for machine processing and using simplified layouts that can be handled and filled in by relatively inexpensive non-professional workers. The system has not been applied yet, and many changes may be needed, but the basic approach will remain the same—namely, to produce rapidly and efficiently catalog cards using student help. The actual application of this cataloging system to IBM cards should be extremely simple. The cards are printed with an overlay indicating clearly the spaces for all the elements to be listed, and these elements are handwritten on the cards after the material to be cataloged has been examined. The actual machine processing (keypunching, interpreting, sorting) would be done by an independent commercial service. The average fee of such services is about \$5-6 per hour. As a general average several hundred cards can be processed in an hour, so the cost for the library will be only a few cents for each finished card.

1. LIBRARY OF CONGRESS. *Annual Report of the Librarian of Congress for the Fiscal Year Ending June 30, 1942*. Washington, D. C.: Government Printing Office, 1943, p. 45.

Author-Title-Performer Materials

These materials are treated by what might be called a "unit" cataloging method and include such items as musical compositions and plays. The cataloging is done by hand-writing the various identifying characteristics on an IBM card having the following distribution for the 80 columns of the card:

| ELEMENTS | NO. OF COLUMNS |
|--------------------------|----------------|
| Classification | 7 |
| Author | 10 |
| Title | 17 |
| Performers | 20 |
| Group card number | 2 |
| Label and Catalog number | 10 |
| Source | 1 |
| Recording media | 1 |
| Media size | 2 |
| Timing | 4 |
| Accession number | 6 |
| Total | 80 |

Some explanation is needed for some of the fields:

Classification. For recorded materials there is practically no standard classification. For printed musical scores a number of detailed schedules have been worked out in the past by major libraries and authorities in the field. The best known schedules are those prepared by Brown, Cutter, Dewey, Library of Congress, Bliss, and the British Catalogue of Music, the latter based on the faceted classification principle of Ranganathan. To illustrate the diversity of these systems, a piano sonata by Beethoven has the following classification code in the different systems:

| | | |
|------------------------|----------------------|------------------------|
| <i>Brown</i> C647.9 | <i>Cutter</i> VZP | <i>Dewey</i> 786.41 |
| <i>LC</i> M23a | <i>Bliss</i> VXPI | <i>B.C.M.</i> QPE |

Author, title, and performer. These three elements are handled in much the same way as in standard cataloging. When the performer is an orchestra or choral group, a sub-field for conductor could be created by assigning to his name the last 6 or 8 columns of the field.

Group card number. As it will be explained later, about 20 per cent of the material cataloged requires one or more expansion cards for the same accession number. On this field the number of such cards is placed.

Source. This indicates whether the recording comes from a broadcast, a disc, another tape, a film soundtrack, a live concert, and so on.

Recording media. This identifies the type of recording—tape, disc, cylinder, etc. A code could be introduced in this same column to indicate the speed of the tape or disc.

Media size. This refers to the diameter of the disc or reel of tape.

It should be mentioned at this point that data with only one alternative, such as stereo or monaural recording, could be coded in terms of a binary code, one with one alternative, generally yes or no, and placed on the card as control punches in the numeric fields. Control punches could also be used for data with few and definite choices. In the case of source, for example, there would only be 6 possibilities: live, broadcast, disc, tape, film, other.

This basic layout would suffice for an estimated 80 per cent of the author-title-performer type of materials. As abbreviations will be used, a single card would be enough for most of the materials. In some cases, however, the spaces provided cannot contain all the information it would be desirable to include. Such cases would be: two or more authors, composer-arranger combinations, or very long names; long titles, nicknames, or names involving complete descriptions of keys, opus, numbers, etc.; and performers in a trio, quartet, opera, or other large work.

For material that needs more expanded cataloging, the following distribution for 80 columns on expansion card(s) is proposed:

| ELEMENTS | NO. OF COLUMNS |
|--------------------------|----------------|
| Classification | 7 |
| Author | 20 |
| Title | 20 |
| Performer | 21 |
| Instrument | 2 |
| Group card number (—of—) | 4 |
| Accession number | 6 |
| Total | 80 |

The fields are self-explanatory. The descriptive data are left out as they already appear on card number 1. Classification is a field that may or may not be left out depending on the use of this element. After "Performer" a field for "Instrument" may be introduced to indicate in code form the instrument that particular individual plays.

The "Group card number" field would show the number of expansion cards that have been prepared for a certain composition and would be expressed in the form "3 of 7." In an opera, for example, there are several soloists, orchestra and conductor, chorus and conductor, and at times other individuals involved. One expansion card can be assigned to each of these individuals or groups. Within the accession number, the group card number will tie all these cards together after the main entry card, which is always number 1.

At the end of the cataloging process there will be a deck of cards arranged alphabetically by author and classification. Secondary decks arranged alphabetically by titles and performers can be easily prepared. Expansion cards could be merged into these files, using perhaps some color coding. For alternate names or nicknames of works or performers or when there is more than one author or an author-arranger combination, "see" cards should be made. They could simply be standard IBM cards with the entire field assigned to an alphanumerical notation, for example: *Pathétique Symphony*—See, Tchaikovsky, *Symph. #6 in b, Op. 74* or Sousa, J. P.—*Stars and Stripes ballet*—See, Kay, H.

Other Materials

Such items as documentaries, lectures, speeches, newscasts, commercials, or sound effects may be cataloged using the principles of coordinate or Uniterm indexing. The materials may be considered exactly like printed documents, and the process is standard for this type of indexing and generally very simple. An item is assigned an accession number, and the cataloger then selects a number of terms that describe the content of the taped material. This selection is based on the program information pasted on the index sheet. If this information is not sufficient, the cataloger may find it necessary to listen to

the program or at least part of it. The Uniterms can be personal names of participants or panelists, nouns, places, trade names, dates, etc. A list of these terms can be attached to the reel or box of tape. This tracing provides a record of the terms assigned to a certain item in case other terms are added in the future, some deleted, or the program is erased.

Each term is given a card of its own where the accession numbers of all recordings dealing with that term are recorded. Searching for a given program or subject can then be done by the standard coordinate indexing procedure. As with printed materials, a simple distribution for the 80 columns of the IBM card could be made as follows:

| ELEMENTS | NO. OF COLUMNS |
|---------------------|----------------|
| Accession numbers | 60 |
| Term | 13 |
| Term account number | 6 |
| Card number | 1 |
| | <hr/> 80 |

The field for accession numbers occupies columns 1 through 60. Punches in this field could be made to interpret accession numbers. For example, a 3 punch in column 16 would mean accession number 163. This coding has two slight disadvantages: 1) the first accession number is 10, and 2) after the number 609 is punched, a second card is necessary. On this second card consecutive numbers can be assigned to columns 1 through 60 starting with accession number 610 to keep the continuity. These disadvantages, however, are minor compared to the conveniences and compactness of this coding method.

The field for the Uniterm is alphanumerical. Thus, it can accept dates or compound names having combinations of letters and numbers.

The term account number can be a very valuable asset to the file, especially for manual alphabetical arrangement. This number can be assigned to the term at the time it is assigned a card for the first time. For this purpose a table such as the *Lefinder Guide*² may be used. This useful table is a sort of

2. LEFAX, INC. *Lefinder Guide*. Philadelphia: 1957, 32 p.

condensed dictionary of the standard English language distributing in a very balanced way numbers 0000 through 9999 from A through Z. We have found that assignment of these numbers or expansions of them (expansions, of course, can be unlimited) to Uniterms is a most valuable asset to the files for either machine or manual alphabetical arrangement.

The last column is reserved for card number to provide for the time when accession numbers exceed 609 and added cards are needed to code the following numbers.

With this dual system of cataloging recorded materials, any program can, of course, utilize the two treatments simultaneously, for example, a documentary program on the life of a composer featuring panel discussions and musical illustrations of his compositions. The accession number would be the same for the entire program, and it would be assigned both to the musical illustrations (unit cataloging with the basic elements author-title-performers) and to the discussion material (coordinate indexing).

General Observations

This system, we believe, provides a fairly adequate cataloging of materials held in a collection. One relative disadvantage that can be cited at once is that some auxiliary tables are needed, for example, the classification schedule or the codes for source or instruments have to be kept in a visible place and users have to learn to use these and similar decoding guides.

At this point the question, for whom are we cataloging?, must be considered. A number of authorities are charging that the existing catalogs are not designed for public use and that catalogers are too tradition-oriented and afraid to experiment. Even with the adoption of the Cataloging Code Revision the catalog's main use will probably be by a trained staff. An administrator and librarian wrote a few years ago:³

. . . I worry about the state of cataloging because I feel that no major break-through has been made in cataloging techniques and utilizing modern devices. As I understand cataloging today, it is basically the same as it was 50 years ago, except

3. GOLDHOR, H. The Worries of a Public Library Administrator. *Library Resources and Technical Services*, vol. 3, no. 2, Spring 1959, p. 119-22.

that we type our cards or Xerox them instead of writing them out; we've changed some rules, but the approach is basically the same. Compare this with the break-through achieved by Henry Ford in industry with his development of the assembly line system of production. Standardized and interchangeable parts, high volume of production, low unit cost, utilizing persons with relatively little skill, and other aspects constituted a revolution in its way such as we need of the same stature in cataloging. More relevant to cataloging is integrated data processing which is automation in the office. It means that information is organized by intelligent human beings once, and thereafter handled automatically by machines according to directions.

The system described here is aimed precisely in this direction. It has been planned with these three objectives in mind:

1. To tackle in a comprehensive way the so far almost insoluble problem of cataloging such difficult special materials such as sound recordings.
2. To prepare cards with inexpensive, non-professional help who receive short training periods and are subject to high turnover.
3. To make the cards suitable for inexpensive and fast duplication and rearrangement of fields, all of which can be achieved by extremely fast and inexpensive machine methods.

The system described can therefore offer, like most mechanized methods, the following advantages:

1. The possibility of placing a maximum of usable data on a minimum of space with a minimum of time and labor.
2. Ease of preparing the cards due to the form-like layouts permitting the use of cheaper non-professional labor.
3. Versatility and low cost of the system:
 - a. Any later modification can be made retroactive, thanks to high speed machine duplication of card decks and rearrangement of fields in almost any desired way.
 - b. Applicable to both large and small collections.
 - c. High speed machine searches.
 - d. Entire decks of cards can be inexpensively duplicated and their contents printed on cards or in book form. Thus, the catalog of an entire library can be made available either complete or in a selective way, and periodical supplements or cumulative catalogs can be prepared at any time.

e. Any number of additional decks of cards can be produced and, through shifting of the fields, organized by function of any other elements. Thus, if the master deck is arranged by author, three additional secondary decks can be produced inexpensively and organized by title, performers, and classification.

In closing, it should be stated that this proposed system is by no means a definitive

or polished one. It needs a sizable pilot project—the only way to work out all the details and refinements. The layouts and operational instructions presented are basically illustrations of what can be done in this field. What I have tried to emphasize is the fact that mechanized methods of data handling and information retrieval are not only possible, but an essential need for special libraries handling sound recorded materials.

Vickery Leads Seminar on Faceted Classification

THE FIFTH OF A series of Seminars on Systems for the Intellectual Organization of Information, which are being conducted by the Rutgers Graduate School of Library Service under the direction of Dr. Susan Artandi and with the support of the National Science Foundation, was devoted to a two-day consideration of faceted classification. B. C. Vickery, a member of the British Classification Research Group and Librarian, The Manchester College of Science and Technology, England, made the major presentation. In his prepared paper he explained that facet analysis is an explicit technique of structuring and controlling vocabulary in a specialized subject field. Stated simply, a list of terms pertinent to a subject area is compiled by examining representative documents and reports and knowing library users and their field. These terms are sorted into categories or facets, such as substance, state, materials, reaction, operations, and agents, and then are arranged in some sort of hierarchical order within each facet. The facets themselves can be arranged for post-coordinate or pre-coordinate indexing. This system has its roots in Ranganathan's colon classification but is utilized primarily in industrial research and development libraries. Mr. Vickery discussed in detail the advantages and disadvantages of facet analysis, the construction of classification schedules, search methods, and use of notations, often citing the English Electric Scheme as an example.

The next morning the tall, blue-eyed Britisher took part in a panel discussion and answered questions directed to him by the audience. Calvin N. Mooers, Rockford Re-

search Institute, questioned the use of terminology rather than symbols or concepts and commented that "classification people are either lumpers or splitters." Alan M. Rees, Western Reserve University, pointed out that faceted classification is a logical indexing rationale rather than a retrieval system or searching tool and suggested that a thesaurus would help link terms in different facets. Prefacing his remarks with the observation that "The creation of a classification scheme is an act of supreme arrogance," Ralph Shaw, Rutgers and the University of Hawaii, noted that uniformity within a classification scheme is a problem, that indexers and users must trust the logic of each facet, and that the more general the terms used, the greater the need for scope notes and cross references. Questions from the audience concerned the technique of chain indexing, problems of compound terms, difficulties of searching and coordinating terms in a faceted scheme, and the use of specific terms versus concepts. The Cranfield Research Project and the results of its tests of the efficiency of facet classification and other indexing systems were referred to frequently. The theoretical and practical discussions were relieved by some good natured bickering.

The 80 or so librarians, system designers, library school students, and others who attended this Seminar were exposed to the intricacies of a classification system that is almost unknown and unused in the United States; if the group with which this reporter returned to New York was typical, the exposure was meaningful and provocative.

m1a

Bibliography on Reproduction of Documentary Information January-December 1964

LORETTA J. KIERSKY

GENERAL

ADAMS, K., JR. The microfilm industry—big business or small business. *National Micro News* (69):212-14, Apr. 1964.

Aerospace Abstracts now available in microfiche. *Sci Information Notes* 6(5):12, Oct./Nov. 1964. Service is offered by the American Institute of Aeronautics and Astronautics and will be supplied by the Technical Information Service, 750 Third Ave., New York 10017.

ARDERN, L. L. Book review, *Microcopying Methods*. (H. R. Verry. London: Focal Press, 1963 [Apr. 1964]. 175p.) *J Doc* 20(3):179-80, Sept. 1964.

ASHTON, G. How EDP will affect the field of reproduction technology. *Reprod Methods* 4(5):14, 61, May 1964.

BAPTIE, A. L. The new publishing prodigy—microfiche. *In: Proc National Microfilm Assn.*, 13:1964.

Bills and Resolutions of 84 Congresses to be included in LC Microfilm project. *Lib J* 89(2):217, Jan. 15, 1964. (News note.)

BOONE, S. M. Current administrative practices in library photographic services 1964. Thesis (M.L.S.) Univ. North Carolina. 81p.

Committee on Fair Use in Photocopying makes recommendations. *Law Lib J* 57:155-56, May 1964.

COOPER, H. G. Computer to microfilm, "a new era." *In: Proc National Microfilm Assn.*, 13:1964.

CROW, J. E. Microreproduction requirements for information processing. *In: Proc National Microfilm Assn.*, 13:1964.

DAGGETT, P. H., JR. Data management system requirements. *In: Proc National Microfilm Assn.*, 13:1964.

DAY, M. S. The NASA microfiche program. *In: Proc National Microfilm Assn.*, 13:1964.

DUNNING, A. W. Letter to Kiplinger Washington Editors, March 25, 1964. *National Micro News* (69):232-33, Apr. 1964. Letter of explanation

of microspots and protest at the warning in the Kiplinger Letter of March 6, 1964.

ECKLES, R. B. Some problems of scholarly publication in photocopy. *National Micro News* (69):215-18, Apr. 1964. Discusses the need for centralization of want list and project reporting for both scholar and publisher.

———. Some problems in scholarly uses of microphoto publication. *Am Archivist* 27:565-67, Oct. 1964.

EVEN, A. Sources of information to aid in selecting retrieval equipment. *Reprod Methods* 4(1):12, 14, 58, Jan. 1964. Includes a few sources of microforms information.

EXELBERT, R., KISH, J. L., and SHOLTZ, P. Educating top management to the importance of microfilm as a business systems tool. *In: Proc National Microfilm Assn.*, 13:1964.

Federal policy change announced on microfilming permanent records. *Lib J* 89:1700+, Apr. 15, 1964.

Ferris gives trained 'answers' to industry's recruiting cry. *Reprod Engr* 8(5):180-81, May 1964. Describes the Graphic Reproductions Course at Ferris State College, Big Rapids, Michigan.

FREEHAFER, E. G. Summary statement of policy of the Joint Libraries Committee on Fair Use in Photocopying. *Spec Lib* 55(2):104-06, Feb. 1964.

HASKETT, J. Let's look at the records. *Reprod Methods* 4(11):54, 56, Nov. 1964. Discusses records management with brief comment on microfilm.

HENN, R. W. and WIEST, D. G. Microscopic spots: a progress report. *In: Proc National Microfilm Assn.*, 13:1964.

HENSEL, J. World-wide exchange of scholarly and industrial microfilm programs. *In: Proc National Microfilm Assn.*, 13:1964.

Indian micropublishers. *Unesco Bul Lib* 18(1):43[50], Jan./Feb. 1964. Further information from Dr. Madhukant Mehta, Reflex Library, 45 Sharda Society, Ahmedabad-7, India.

INGERMAN, E. A. The Joseph Downs manuscript and microfilm library. Winterthur Portfolio one: 151-59, 1964.

International Congress for Reprography, Cologne, October 1963. *Unesco Bul Lib* 18:92-93, Mar. 1964.

Miss Kiersky is Librarian at Air Reduction Company, Inc., Murray Hill, New Jersey, and SLA's Special Representative to the National Microfilm Association.

JOHNSON, R. K. RTSD Copy Methods Section annual report, 1963/64. *Lib Res & Tech Serv* 8(4):439-40, Fall 1964.

KIERSKY, L. J. Bibliography on reproduction of documentary information, January-December 1963. *Spec Lib* 55(3):160-65, Mar. 1964.

———. Book review, *Microcopying Methods*. (H. R. Verry. London and New York: Focal Press, 1963. 175p. \$10.50) (Dist. in U. S. by Pitman Publishing Corp.) *Spec Lib* 55(9):649, Nov. 1964.

———. National Microfilm Association: Report of the SLA special representative for 1963-1964. *Spec Lib* 55(7):503-04, Sept. 1964.

LC reports on expansion of photocopying abroad. *Lib J* 89:2310, June 1, 1964.

Libraries want free right to photocopy. *Pub Wkly* 185:36, June 15, 1964.

Library of Congress microfilms Soviet National Bibliography. *Lib J* 89(6):1208, Mar. 15, 1964. All issues from 1907-1946 available for purchase from Photoduplication Service, Dept. C, Library of Congress, Wash., D. C. 20540.

LYNER, P. E. Planning and micro-records. *Northern Ireland Lib* (News sheet of the Northern Ireland Branch of the Library) 5:4-5, May 1964.

MARTIN, J. E., JR. Second annual survey: Education for reproductions. *Reprod Rev* 14(8):20-23, 68, Aug. 1964. Lists colleges and schools having courses in reprography.

Microfilm defects. *Am Archivist* 27(2):297, Apr. 1964. Reported statement of E. E. Olson, Salt Lake City that examination of microfilm did not reveal any spots.

Microfilm "rash" plagues archives. *Antiquarian Bkman* 33:2432, June 1-8, 1964.

Microfilm "rash" plagues archives; spots on records disturb U. S. and industry. *New York Times* 114:84, col. 7, May 17, 1964.

Microfilm's diverse and unusual applications. *Ind Phot* 13(8):34-35, Aug. 1964.

Microfilm's measles: just a scare? *Ind Phot* 13(9):109-12, Sept. 1964. Analyses indicate that the blemishes are produced by a local oxidation of silver grains to soluble form. In no case reported has the text of an archival film been damaged.

Microscopic spots or defects on microfilm. *Am Archivist* 27(1):142-44, Jan. 1964. Reports the opinions of National Bureau of Standards, Bell & Howell Co., Eastman Kodak Co., and others.

More about microfilm "measles." *Office* 60(4):64, Oct., 1964. Statement of University Microfilms that no damage was found in the image area of the millions of feet of film in its files.

MUTCHER, P. K. Copyright law and photoduplication in the library. *Felicitier* 9(8):12-18, Apr. 1964.

NELSON, C. E. Convention comments: National Microfilm Association, Philadelphia, April 27-29, 1964. *Systems* 5(4):52-53, July/August 1964.

———, moderator. Microfilm: where it is . . . where it's going. *Systems* 5(6):41-44, 46, Nov./Dec. 1964. Summary of major questions posed and points made during the Second Annual SYSTEMS Microfilm Seminar, New York.

New York Times article on microscopic spots. *National Micro News* (70):274-76, June 1964.

NICHOLSON, A. L. Copyright, photocopying, and library service, Letter to the editor. *Spec Lib* 55(8):585, Oct. 1964.

Outer space microfilm library included in World's Fair exhibit. *Lib J* 89:1700+, Apr. 15, 1964.

PEELE, D. Bind or film: Factors in the decision. *Library Res & Tech Serv* 8(2):168-71, Spring 1964.

Photocopy encroachments alarm U. S. publishers. *Bookseller* (3048):1968, May 23, 1964.

Photocopying can help you. *Office Mag* 11(128):594-615, Aug. 1964.

Photocopying of still pictures in the Prints and Photographic Division of the Library of Congress. *Lib Cong Inf Bul* 23:428-29, Aug. 10, 1964.

Pre-Convention [National Microfilm Association] Microfiche Session: AEC and microfiche, E. J. Brunenkant; NASA microfiche concept, M. S. Day; DOD interest in microform standards; Technical Documentation Center, OTS. *National Micro News* (71):8-20, Aug. 1964.

Register of master microfilms. *Unesco Bul Lib* 18(5):245-46[343] Sept./Oct. 1964. Data sheets on request and further information from Microfilm Clearing House, Union Catalog Division, Library of Congress, Washington, D. C. 20540.

SAHA, J. Document reproduction: a plea for co-operation. *Lib Sci* (India) 1(1):80-96, Mar. 1964.

SAXENA, T. P. Reprography for libraries. *Indian Libn* 18:223-26, Mar. 1964.

Six biggest problems in office reproduction. Report of the National Reproduction Processes Committee of the Administrative Management Society. *Admin Mgt* 25(8):45, Aug. 1964. Results of a survey.

STATES, H. W. Retrieval and reproduction, present and future. *National Micro News* (71):2-7, Aug. 1964. Adapted from a paper presented at the Systems & Procedures Association Spring 1964 Conference, San Francisco, Calif.

STONE, R. K. What's in a name?—Guidelines for systems planning. *Reprod Rev* 14(5):44, 46, May 1964. Discusses the naming of reprographic processes, equipment, and materials.

Study underway of facsimile transmission system for technical information. *Sci Information Notes* 6(4):11, Aug./Sept. 1964. Houston Research Institute, Houston, Texas, is conducting the survey.

TAUBES, E. P. Microfilm as a systems tool. *National Micro News* (68):151-69, Feb. 1964. Adapted from a paper presented at the First International Congress for Reprography, Cologne, Germany, Oct. 1963.

TATE, V. D. Microreproduction references. *Reprod Methods* 4(4):30-31, Sec. 1, Apr. 1964. A basic selection of current literature in this field.

———. Microscopic blemishes and the storage of permanent record microfilm, in perspective. *National Micro News* (70):241-48, June 1964. Discusses the problem pointing out important and significant facts. (Single copy, ten cents postage, available from the author, P. O. Box 386, Annapolis, Md.)

Three references on aging blemishes. *National Micro News* (68):170-73, Feb. 1964.

Toscanini Memorial Microfilm Archive to be housed in NYPL Music Division. *Lib J* 89(5):1052, Mar. 1, 1964. (News note.)

ULLRICH, O. A. and WALKUP, L. E. Challenges in microimage publishing. *Reprod Methods* 4(10):36, 56, 58, Oct. 1964. Summary of paper presented at the 16th Annual Meeting of the Technical Association of the Graphic Arts, Pittsburgh, June 1-3, 1964. Discusses the possibilities and the advantages for readers, publishers and libraries.

Unesco mobile microfilm unit in the United Arab Republic. *Unesco Bul Lib* 18(6):295[421], Nov./Dec. 1964. A list of all the manuscripts microfilmed can be obtained from the National Library, Midan Ahmed, Cairo (U.A.R.).

VALENCIA, V. N. Microfilming program and services of the National Power Corporation (Philippines). *ASLP Bul* 10(1):6-8, Mar. 1964.

VEANER, A. B. European report: Reprography Congress document reproduction activities in French and British libraries. *Lib Res & Tech Serv* 8(2):199-204, Spring 1964.

VERRY, H. R., ed. Document reproduction. *Rev Int Doc* (The Hague) 31(3):117-20, Aug. 1964. Reviews equipment and processes.

WEIS, M. M. Imagination, ingenuity—significant elements in an effective microfilm program. In: *Proc National Microfilm Assn.*, 13:1964.

WESEMAEL, A. L. van. Impressions from the First International Reprography Congress. *Bibliothek-leven* 49:12-19, Jan. 1964. (In Dutch.)

WIEST, D. G. and HENN, R. W. Microscopic spots: a progress report. *National Micro News* (70):249-57, June 1964. Spots are described and illustrated, and techniques for inspection of microfilm collections are given. Procedures for improved storage and a gold protective processing treatment are described. Note: Paper published in advance of presentation at the National Microfilm Association Convention and in NMA Proc 13:1964. (Single copy, ten cents available from V. D. Tate, P. O. Box 386, Annapolis, Md.)

WOLF, D. R. Microfilm applications in business situations. *Office* 59(4):74-75, Apr. 1964. A general comment that includes library applications and gives a chart to show how records are filed on microfilm.

———. Microfilm topics: Finding answers fast and efficiently. *Systems* 5(3):40, 46, May/June 1964. Describes the NASA search program and the use of STAR.

———. Microfilm topics. Handling information search and storage. *Systems* 5(2):43, 55, Mar./Apr. 1964. Discusses two major services, current awareness and retrospective searches.

———. Microfilm topics: The potential of microfilm in publishing. *Systems* 5(1):40, 42, Jan./Feb. 1964.

WOLF, M. H. Survey: Manufacturer's training facilities. *Reprod Rev* 14(8):26-28, Aug. 1964. Describes consumer training programs for supervisory and technical personnel concerned with reprographic equipment.

WOOLEY, O. F. Progress through EDMS (Engineering Data Micro-Reproduction Systems). In: *Proc National Microfilm Assn.*, 13:1964.

PUBLICATIONS

AMERICAN LIBRARY ASSOCIATION. LIBRARY TECHNOLOGY PROJECT. *Fifth annual report for the period July 1, 1963-June 30, 1964*. Chicago: 1964. Annual. Apply.

Annual Report of the Librarian of Congress for the Fiscal Year Ending June 30, 1963. Wash., D. C. 20541: Library of Congress, 1964. 169p. pap. and cloth. Apply.

AVEDON, D. M. *Glossary of terms for Microphotography and Reproductions made from Micro-Images*, 3rd ed. (NMA Informational monograph no. 2). Annapolis, Md. (P. O. Box 386): National Microfilm Association, 1964. 67p.

BALLOU, H. W., comp. *Guide to microreproduction equipment* (Suppl. B to the 1962 ed.). Annapolis, Md. (P. O. Box 386): National Microfilm Association, 1964. 136p. \$5.

Basic Collections in Microedition: Botany. Tumba, Sweden: International Documentation Centre AB (Hågel Hus), 1964. 46p. On request.

Basic Collections in Microedition: Humanities. Tumba, Sweden: International Documentation Centre AB (Hågel Hus), 1964. 32p. On request.

Basic Collections in Microedition: Slavonics (Supplement). Tumba, Sweden: International Documentation Centre AB (Hågel Hus), 1964. 7p. On request.

COUNCIL ON LIBRARY RESOURCES, INC. *8th annual report for the year ending June 30, 1964*. Wash., D. C. 20036 (1025 Connecticut Ave., N. W.). Annual. On request.

DIAZ, A. J., ed. *Guide to Microforms in Print, 1964-1965*. Wash., D. C. (901-26th St., N. W.): Microcard Editions 1964. 94p. pap. \$4. Compilation of publishers' lists with prices.

FEDERATION INTERNATIONALE DE DOCUMENTATION. *Manuel pratique de reproduction, documentation et de sélection* (FID publication no.

353). Paris: Gauthier-Villars, 1964. 341p. 46NF. Available through dealers in imported books.

HAWKEN, W. R. *Photocopying from bound volumes*, Supplement nos. 1 and 2 (LTP publication no. 4 suppl. 1 and 2). Chicago: American Library Association, 1964. \$2 each.

———. Supplement no. 3. 1964. \$5.

HEINZ, G. and PETERSON, A. F., comps. *NSDAP Hauptarchiv: Guide to the Hoover Institution Microfilm Collection*. Stanford, Calif.: Hoover Institution on War, Revolution, and Peace, 1964. 175 p. pap. \$4.50. In addition to the microfilms of the German Nazi Party, the collections of Streicher and Himmler are included. Prices of the reels are given.

Libraries and Automation; proceedings of a Conference held at the Airlie Foundation, May 26-30, 1963. Wash., D. C. 20402: Supt. of Doc., Govt. Printing Off., 1964. 268p. \$2.75.

MCCAMY, C. S. *Inspection of processed photographic record films for aging blemishes* (NBS Handbook 96). Wash., D. C. 20402: Supt. of Doc., Govt. Printing Off., 1964. 11p. 25 cents.

MCREYNOLDS, H. *Microforms of United States Government Publications* (Occasional paper no. 69). Univ. Illinois Grad. School Library Sci., 1964. 13p. bibl. Apply.

Microfiche Foundation Newsletter. Delft, The Netherlands (101 Doelenstraat): Microfiche Foundation. Subscription \$5.

Mighty Miniatures. New York: Grisco Products Corp., 1964. Illustrated booklet discusses why engineering design and developments are important to up-to-date microfilm equipment. On request.

NATIONAL MICROFILM ASSOCIATION. *Proceedings of the Thirteenth Annual Meeting and Convention, National Microfilm Association, Philadelphia, Pa., Apr. 28-30, 1964*. Ed. by V. D. Tate. Annapolis, Md. (P. O. Box 386): 1964. \$9; members \$4.50.

Newspapers on microfilm, 9th ed., 1964-1965. Cleveland: Micro Photo Div., Bell & Howell Co., 1964. On request.

SALMON, S. R. *Specifications for Library of Congress microfilming*. Wash., D. C. 20541: Lib of Congress, 1964. 21p. Apply.

SCHWEGMANN, G. A., JR., comp. *Newspapers on microfilm*. Wash., D. C. 20541: Lib of Congress, 1964. 305p. Apply.

TILTON, E. M., comp. *A Union List of Publications in Opaque Microforms*, 2nd ed. New York and London: Scarecrow Press, Inc., 1964. 744p. \$15. (In England distr. by Bailey Bros. & Swinfen, £7,10s).

UNIVERSITY MICROFILMS, INC. *Microfilm Catalogue No. 15*. Ann Arbor, Mich., 48107 (313 N. First St.): 1964. 77p. pap. On request.

———. *O. P. Cumulation*. 1964. 270p. pap. Catalog of out-of-print books available from Univer-

sity Microfilms in Xerographic copy format. On request.

VAN DER WOLK, L. J. *Microfiche for the research worker* (Publications on Microfiche No. 2). Based on a paper read at the First International Congress on Reprography, Cologne, Oct. 14-19, 1963. Delft, Netherlands (101 Doelenstraat): Microfiche Foundation, 1964. 7p. 50 cents.

METHODS AND PROCESSES

ANDERSON, M. G. Vesicular systems for high resolution generation printing. *In: Proc National Microfilm Assn.*, 13:1964. Discusses Kalvar film and microfilm generation printing as in Mil Std 9868.

ASHTON, G. Latest data on Abram Games' copying process called "Imagic." *Reprod Methods* 4(3):14, 28, 63, Mar. 1964. This high speed process of a British inventor uses infra-red radiation as a heat source.

AXFORD, A. J. O. and GILBERT, J. Characteristics of electrophotographic papers. *J Photogr Sci* 12(1):20-27, Jan./Feb. 1964. Discusses the surface charge under certain conditions and with relation to the machine design.

BARNES, J. C. Rapid processing of Recordak Micro-File film at elevated temperatures. *In: Proc National Microfilm Assn.*, 13:1964.

BECK, R. J. and CONDITT, P. C. To xerox or not to xerox. *PNLA Q* 29:19-25, Oct. 1964.

BROWN, M. C. A book catalog at work. *Lib Res & Tech Serv* 8(4):349-58, Fall 1964. Discusses the production of a book catalog by several methods including microphotography and sequential card cameras. Cost comparisons are noted as well as advantages and disadvantages of the methods.

CAMPBELL, D. R. For efficiency and economy put the copier where the work is. *Reprod Engr* 8(2):47-48, 65, Feb. 1964.

CAWLEY, T. What is a fair price for a xerox copy, Letter to the editor. *Lib Assoc Record* 66(5):238, May 1964. See also Loynes, S. R. and Green, N.

DENTSMAN, H. The long and the short. *Ind Phot* 13(2):14, 71-74, Feb. 1964. Discusses continuous tone films used in copying processes as a recording material.

Electric photography speeds reproduction. *Business Equip Digest* 4(4):48, Apr. 1964.

Enlarged and reduced "stats" are made without a dark room. *Machine Design* 36:15, July 2, 1964.

European newsletter: The "Imagic" story. *Ind Phot* 13(3):8, 81, Mar. 1964. Describes a distillation method of document copying devised by Abram Games and called "Imagic."

Four ways to copying: offset, stencil, spirit and photocopying machines. *Business Equip Digest* 4(4):70-71, Apr. 1964.

FRANKLIN, W. R. A new look at diazo. *Systems* 5(1):25-26, Jan./Feb. 1964.

- FREY, H. C. and RUBIN, H. E. Microdensitometry in a microfilm program. *In: Proc National Microfilm Assn.*, 13:1964.
- GALE, F. M. The copier—Our great efficiency machine. *Reprod Engr* 8(2):43-44, 68-69, Feb. 1964. Reviews the present methods of copying and classifies copying into four categories: documentary, systems, making masters, and general office copying.
- GREEN, N. What is the fair price for a xerox copy, Letter to the editor. *Lib Assoc Rec* 66(9):406, Sept. 1964. See also Cawley, T. and Loynes, S. R.
- GUILDING, N. W. The use of the Xerox 914 for the reproduction of sheaf catalogue entries. *J Doc* 20(4):205-11, Dec. 1964. Discusses the duplicating of catalog entries to supply several libraries at Durham University Library.
- Half-size prints. *Mech Eng* 86:66, Mar. 1964. System at Norfolk Naval Shipyard produces reduced-size intermediates on film using Revolute equipment.
- HANSON, D. E. Liquid development of electro-photographic images for office copy processes (Paper presented at the TAPPI Coatings Conference, New Orleans, May 5, 1964). *TAPPI* 47(9):149A-50A, Sept. 1964. Reprinted *Reprod Methods* 4(10):44-45, 59, Oct. 1964. Selection of suitable materials for the liquid developer depends upon the end use requirement. Factors such as safety in handling, toxicity, convenience, and cost must be considered.
- HOLLIDAY, R. H. Modern microfilm production through the eyes of a production manager. *In: Proc National Microfilm Assn.*, 13:1964.
- HOLMES, D. C. Quality control at the Library of Congress. *In: Proc National Microfilm Assn.*, 13:1964.
- KERFORD, F. J. Microfilm record setup cuts costs and labor of bulk paper retention. *Systems* 5(2):40-41, 51, Mar./Apr. 1964. Describes microfilming project in which the contents of 2,000 five-drawer file cabinets were put on 16 mm film and then inserted into 5 x 8-inch file jackets.
- KRONICK, D. C. Photocopying processes. *Reprod Methods* 4(12):52, 68, Dec. 1964. Excerpts from "A Comparison Analysis of Photocopying Processes." Thesis, Graduate School of Business Administration, New York University. Describes a survey and reports on the results.
- KUTCHERA, A. W. Unitized film processing. *In: Proc National Microfilm Assn.*, 13:1964.
- LANGFORD, M. "Imagic" story. *Ind Phot* 13:8+, Mar. 1964.
- LOYNES, S. R. What is a fair price for a xerox copy, Letter to the editor. *Lib Assoc Rec* 66(7):322, 1964. See also Cawley, T. and Green, N.
- Making a few copies of a slide is a job you can do yourself. *Ind Phot* 13(10):24-25, Oct. 1964. A chart is given with a description of copying methods for slides.
- Making maps from diazo masters. *Reprod Methods* 4(5):39, 61, May 1964. The Ektalith method is used to produce images on conventional drafting film. This process furnishes a translucent master suitable for diazo reproduction.
- MARTYN, A. W. Document copying with silver halide processes. *Brit J Phot* 111:792-96, Oct. 1964.
- MERIGAN, W. H. Man that copy machine! *Admin Mgt* 25(10):18, Oct. 1964. Discusses the advantages of having a trained operator on the machine.
- Microfiche. *Reprod Methods* 4(4):40-41, 58, Sect. 1, Apr. 1964. Discusses advantages offered by this unitized microform for distribution of technical documents, for reference and publishing.
- Microrecording. *Ind Phot* 13(2):80-81, Feb. 1964. Describes the systems for microfilming drawings and technical reports at several Armed Services facilities.
- MITCHELL, E. P. Transition to microfilm. *Reprod Methods* 4(12):32-34, Dec. 1964. Describes the procedure for setting up the program and making the transition to microfilm.
- Modern look in graphic data processing. *Automation* 11:22-23, July 1964. Describes Photochromic Micro-Image (PCMI) and long distance xerography (LDX) among other systems.
- NIESET, R. T. The Kalvar system of photography. *Reprod Methods* 4(9):56, Sept. 1964. Summary of a paper presented at the 16th Annual Meeting of the Technical Association of the Graphic Arts, Pittsburgh, June 1-3, 1964. Kalvar film is used for some microfilm applications.
- Office Operators*. New York: Royal McBee Corp., 1964. Learn how to cut costs with typewriters and copying machines.
- OKELL, C. E. Diazosystems: How to cut the cost of information repetition. *Systems* 5(2):4-5, Mar./Apr. 1964.
- PEACOCK, M. How general is General Purpose Bond. *Reprod Rev* 8(3):91-92, 96, 107-108, Mar. 1964. General Purpose Bond (GP Bond) is the name for a type of paper that can be used for business documents and also as a master for diazo process copiers.
- Personalized office copies. *Reprod Methods* 4(11):34, Nov. 1964. Printed messages called "Xeromarks" can be made to appear automatically on each copy made on a Xerox 813 copier. The service is free if a copier has been installed.
- Photocopying: Condensed information. *Prod Eng* 35(20):46-47, Sept. 28, 1964. Describes the Photo-Chromic Micro Image (PCMI) system at Electronics Division, National Cash Register Co., Hawthorne, Calif.
- Photographic reproduction and projection photocopying; called Photo-Chromic Micro Image. *Product Eng* 35:46-47, Sept. 28, 1964.
- PIEZ, G. T. Library Technology Project Report, Film coatings. *Spec. Lib.* 55(5):307, May/June

1964. Announces a test of film coatings for scratch resistance and other characteristics.

Reproduction Methods survey on office copiers. *Reprod Methods* 4(10):40-43, Oct. 1964. Subscriber replies to questions on type of copying machine and use in making offset masters.

REVES, H. F. Microfilm eases recovery from disaster. *Reprod Rev* 8(8):271-72, 289, Aug. 1964. Describes program for microfilming documents and drawings stained and damaged by water and fire.

The revolution in office copying: Special report. *Chem & Eng News* 42(28):114-25, 127-31, July 13; (29):84-96, July 20, 1964. Describes copying machines and methods now in use and also explores new techniques in the research and development stage.

ROCKHOLD, W. R. Diazosystems: Adding current data to existing records. *Systems* 5(3):4, May/June 1964. Describes method for adding machine data periodically to a record kept on translucent stock by means of a marginally punched, pressure-sensitive, translucent label.

SCHMIDT, G. The levitation principle—its application and progress. In: Proc National Microfilm Assn., 13:1964. Discusses this principle and its application to Levitron process machines and archival quality.

SCOTT, P. Review of copying methods: 1963. *Lib Res & Tech Serv* 8(2):131-44, Spring 1964.

SIMONE, C. P. What job cost control can do for microfilming operations. In: Proc National Microfilm Assn., 13:1964.

STEELE, L. L. Protection and rejuvenation of microfilm rolls and aperture cards. In: Proc National Microfilm Assn., 13:1964.

SUYDAM, W. S. Scratch resistant parameters of microfilm emulsions. In: Proc National Microfilm Assn., 13:1964.

TREYZ, J. H. Equipment and methods in catalog card reproduction. *Lib Res & Tech Serv* 8(3):267-78, Summer 1964.

U. S. Naval Underwater Weapons System Engineering Center (NUWSEC) has a variety of reproduction output. *Reprod Methods* 4(6):35-39, June 1964. Includes a chart (p. 36) that gives an analysis of labor and material costs for hard copy reproduction.

WEILL, P. R. Microfilm focuses on retrieval. *Admin Mgt* 25(6):70-81, June 1964.

What's new in electrostatic printing. *Reprod Rev* 14(3): 21-22, Mar. 1964. Review of last year's developments.

WILSON, T. Relationship between microfilm negatives and hard copy print-out. In: Proc National Microfilm Assn., 13:1964. Describes ultraviolet projection of microfilm and reports on a study of diazo print-out.

WINZ, R. M. The technical order library in orbit. *STWP Rev* 11(1):2-4, Jan. 1964. Discusses the

technique of photochromic microimages (PCMI). Work continues on microstorage. *Bookmark* 23:307, July 1964.

Xerox's 1860 Printer reduces by electrostatic photography. *Reprod Rev* 14(6):60, June 1960. Reduction ratios range downward from 95 per cent to 45 per cent of the original size.

Xerox introduces "masterless" copying system. *Reprod Engr* 8(12):447, Dec. 1964. Describes the Xerox 2400 copying machine.

EQUIPMENT

The all-British Ozafax 20: first British-made electric photocopier enters the field. *Small Offset User* 13(150):281, Apr. 1964.

BALLOU, H. W. Copying methods notes: Microform equipment. *Lib Res & Tech Serv* 8(3):323-28, Summer 1964.

BOYETT, D. Microfilm readers and reader-printers. *National Micro News* (68):174-88, Feb. 1964. Includes a chart that gives comparative specifications of a number of readers and reader-printers.

BROOKS, B. Selecting the "right" portable Office Copier. *Systems* 5(2):25-28, Mar./Apr. 1964.

Copying by heat; a commentary on infra-red photocopiers. *Business Equip Digest* 4(3):4-7, Mar. 1964.

Dagmar reader-printer for microfiches. *Unesco Bul Lib* 18(6):297[429] Nov./Dec. 1964. Information available from J. H. Mullens N. V., Newtonstraat 413-419, The Hague, Netherlands.

The Damier microfiche camera. *Unesco Bul Lib* 18(5):245[342] Sept./Oct. 1964. Further information can be obtained from Microfilmex, 75 rue Saint-Lazare, Paris 9^e, France.

DENTSMAN, H. Reproduction manager: Let's take stock. *Ind Phot* 13(4):4, 26, Apr. 1964. Describes the use of the Polaroid Land materials and equipment for copying various types of originals including those in color. Suggests Polaroid copies for approvals.

DEVITT, J. and BENNETT, H. High speed planetary camera. In: Proc National Microfilm Assn., 13:1964.

Diazo reproduction equipment. *Reprod Methods* 4(7):34-35, July 1964. Chart gives model number and price as well as other data for the diazo machines of 13 manufacturers.

Equipment data sheet 1—Microfilm cameras. *Reproduction* 1(1):10-11, Feb. 1964.

Equipment data sheet 2—Dyeline photocopiers. *Reproduction* 1(3):6, Apr. 1964.

FARLEY, E. Combined procedures for technical processes. *Lib Res & Tech Serv* 8(3):257-65, Summer 1964. Discusses use of Recordak Microfile camera Model MRD-2, Xerox Copyflo, and Xerox 914 for cataloging and acquisitions and gives cost figures.

Fume control for copiers. *Product Eng* 35:69, Oct. 12, 1964.

HEADLEY, G. R. Choosing a photocopier, No. 1: Copier with a magic eye (Planocop Electronic). *Reproduction* 1(1):22, Feb. 1964.

———. Choosing a photocopier, No. 2: Two of a kind (Remington L250 and L400 and Roneo Streamliner and Streamliner Major). *Reproduction* 1(2):22-23, Mar. 1964.

———. Choosing a photocopier, No. 3: Instant strike dyeline (Anson B-Line Major and B-Line Minor). *Reproduction* 1(3): 12-13, Apr. 1964.

HERZOG, R. H. Match reproduction equipment to needs. *Office* 59(5):168, 170-71, May 1964. Adapted from a talk at a meeting of the Boston Security Analysts Society, this article discusses number of copies and cost.

HILL, W. J. Regiscope photocharger. *Lib W* 65: 364-66, May 1964.

KIERSKY, L. J. Developments in document reproduction. *Spec Lib* 55(2):114-15, Feb. 1964.

———. Developments in document reproduction. *Spec Lib* 55(6):388-89, July/Aug. 1964.

KLEINSCHROD, W. A. Updating the facts about copiers. *Admin Mgt* 25(3):29-34, 38+, Mar. 1964. Review of 189 machines and trends of the past year.

Microfilm enlargers. *Reprod Methods* 4(7):42-43, July 1964. Chart gives data including price for the models of 19 manufacturers.

Notes on new reprographic equipment. *Brit J Phot* 111:798-99, Oct. 1964.

Photocopiers: one minute survey. *Office Equip News*, Mar. 1964: 26-27.

Projector unit stores, displays and copies maps. *Reprod Engr* 8(12):448, Dec. 1964. Describes a machine combining a projector and electrostatic copying unit that can select and automatically project maps from 70mm slides and produce a copy in less than 20 seconds.

Reader-printer project. *Am Archivist* 27:325-26, Apr. 1964.

Reflex copiers are so versatile. *Business Equip Digest* 4(5):4, 7, May 1964.

Regiscope bookcharger/printer. *Unesco Bul Lib* 18(6):297[428] Nov./Dec. 1964. Information available from Regiscope Corporation of America, 7 East 43rd St., New York 10017.

ROOT, A. C. Impact of microfilm on retrieval hardware. In: Proc National Microfilm Assn., 13: 1964.

Think small; a report on microfilm for the office. *Modern Office Proc* 9(7):29-33, July 1964. Discusses cameras, processing, and filing, and includes a microfilm equipment chart.

APPLICATIONS

ALLISON, H. Microfilming at Burroughs paid for itself in 18 months. *Reprographics* 2(6):30-31, Dec. 1964. Discusses several applications of the 105 mm microfilm system.

ALLYN, W. H. Do-it-yourself Xerox. *Ohio Lib Assn Bul* 34(4):3-6, Oct. 1964. Describes the costs of operating a machine on a self-service basis at Ohio University Library.

BALLOU, H. W. Copying methods notes: The microfiche. *Lib Resources & Tech Serv* 8(1): 81-85, Winter 1964.

———. Copying methods notes: Microform picture windows. *Lib Res & Tech Serv* 8(4):449-55, Fall 1964.

BARTON, W. Library and microfilm; a preliminary survey of microfilm practice in German libraries with special consideration of newspaper filming. *Z Bibl u Bibliog* 11(3):127-47, 1964. (In German.)

BEAUCLAIR, W. DE. Special applications of microfilm and microfilm sheet. *Reprographie* 4(5): 107-11, July/Aug. 1964. (In German.)

BECKER, J. Automatic preparation of book catalogs. *ALA Bul* 58(8):714-18, Sept. 1964. Includes the use of cameras for photographing catalog cards at high speed.

Better informed at lower cost. *Reprod Engr* 8(12):434, 453, Dec. 1964. Describes the preparation of a weekly bulletin at Du Pont that includes a Xerox Copyflo and other equipment.

BROOKS, B. Uncle Sam finds microfilm saves money, time and space. *Systems* 5(1):35-39, Jan./Feb. 1964. Briefly describes a number of applications including Library of Congress catalog cards.

CARLSON, E. C. New uses for microfilm in industry. In: Proc National Microfilm Assn., 13: 1964.

Centralized register of all master negatives of microfilms planned in cooperation with the Association of Research Libraries. *Wilson Lib Bul* 38:455, Feb. 1964.

CHAPEL, R. J. All the news that's fit to microfilm. *Systems* 5(2):52-53, Mar./Apr. 1964. One suggested application for microfilmed newspapers is the grouping of a series of articles by inserting microfilm into jackets or mounted in aperture cards.

CLICKENGER, J. O., MATSUMIYA, H., and BLOOMFIELD, M. Why we microfilmed our library card file. *Office* 60(1):20, 22+, July 1964. The union card catalog was microfilmed and cartridges were used to contain the film. Costs are given for supplying branches, for updating, and for a projected ten year period.

Combination shaves two days from time spent on monthly billing. *Systems* 5(1):30-31, Jan./Feb. 1964. Describes an application for updating records by the use of translucent cards with strips of magnetic tape on the backs. The method combines magnetic storage and diazo reproduction.

Copy machines and forms go hand-in-hand. *Systems* 5(4):40-41, July/Aug. 1964. Describes the application of Thermo-Fax systems paper to various purchasing-receiving situations.

- Copying machine restores burned records. *Office* 60(5):63, Nov. 1964. Sheets enclosed in a transparent carrier were fed through a copier which was adjusted to overexpose or underexpose. Cost cutting comes by copying. *Reprod Engr* 8(2):50, 52, 66, Feb. 1964. Carrier Corporation saved by adding a copying system for purchase orders that included an Ozamatic 60 diazo machine.
- CRAMER, J. Diazosystems at work: Planning plus diazo can cut your copying costs. *Systems* 5(6):14, 57, Nov./Dec. 1964. Among the applications noted is the use of diazo masters in the preparation of forms.
- DEWEZE, A. Automated establishment and utilization of bibliographical citation indexes. *Unesco Bul Lib* 18(5):211-23[294] Sept./Oct. 1964. Sect. 2.4 describes the microfilm card file (columns 14-80) on the master tab card.
- Diazosystems: Open-end system cuts processing time. *Systems* 5(4):4-5, July/Aug. 1964. The procedure has reduced typing time by using diazo reproductions in a purchasing application.
- Directories of documents reproduced by the Unesco Mobile Microfilm Unit. *Unesco Bul Lib* 18(1):44-45[52], Jan./Feb. 1964.
- Electrostatic copying unit lightens paperwork load. *Admin Mgt* 25(12):62-64, Dec. 1964. System uses the Bruning Model 2000 electrostatic copying machine.
- ELLINGER, W. B. Use of a sequential camera for composition of a list of subject headings. *Law Lib J* 57(3):217-23, Aug. 1964.
- Floating University gathers teaching aids. *Office* 60(2):60, Aug. 1964. Microfilmed material from the University of Seven Seas is used to teach first graders in a San Diego school.
- HAMANN, E. G. This works for us: Xerography for University (of New Hampshire Library) periodicals list. *Spec Lib* 55(8):581, Oct. 1964.
- HIRSH, P. Electronography: Computer prepares catalog data in full page format. *Reprod Rev* 14(9):32, 34, Sept. 1964. Preparation of a Navy parts catalog using microfilm.
- JONES, B. The compact book catalog by photographic process. *Lib Res & Tech Serv* 8(4):366-69, Fall 1964.
- JORGENSEN, W. E. One picture is worth a thousand [typed] words. *Lib Res & Tech Serv* 8(2):196-98, Spring 1964. Discusses production of catalog cards on the Xerox 914 copier.
- Management gets data faster through copier. *Admin Mgt* 25(4):60-62, Apr. 1964.
- MARTIN, J. A. and FERGUSON, M. S. Photocopying in a researching library. *Bul Med Lib Assn* 52(2):410-13, Apr. 1964.
- MATSUMIYA, H. and BLOOMFIELD, M. A working microfilm card catalog. *Spec Lib* 55(3):157-59, Mar. 1964. Describes the Hughes Aircraft Company's union catalog.
- MAYNARD, T. G. Microfilm in the graphic arts *In: Proc National Microfilm Assn.*, 13:1964.
- MUNDY, E. H. Slashing paperwork bills \$750 a month. *Systems* 5(6):19, Nov./Dec. 1964. Describes some applications of the Verifax Viscount Copier.
- Music publisher makes copies by the "score." *Office* 59(4):53, Apr. 1964. Use of a copying machine to provide rental copies of music that cannot be sold outright.
- PENZOLD, L. Should microfilms replace original copy in interlibrary loan? *Zentral Biblio* (9):526-28, 1964. Presents the advantages of using microfilm. (In German.)
- PIZER, L. H. Another look at printed card catalogs, Letter to the editor. *Spec Lib* 55(2):119, Feb. 1964. Reply to R. C. Jones, Compact card catalog: being a printed book catalog by photographic process. *Spec Lib* 54:625-26, Dec. 1963.
- PREISS, H. R. Engineering drawings in a hurry. *Pub Works* 84:155-60, Oct. 1964.
- PULA, F. J. Make it visual with diazo. *Reprod Engr* 8(4):121-22, 138, Apr. 1964. Discusses overhead projection techniques and production of diazo masters.
- Put your drawings on active microfilm. *Engineering* 198:358, Sept. 18, 1964.
- RAUCH, J. S. Additional application of photocopying in the operation of a current awareness service. *Med Lib Assn Bul* 52:592-93, July 1964.
- RHYDWEN, D. A. The application of microphotography to newspaper clippings. *Spec Lib* 55(1):28-30, Jan. 1964.
- ROSE, M. et al. Microfilm system saves city \$75,000 a year. *Office* 60(6):76-77, 174+, Dec. 1964. Discusses microfilmed New York City Health Department records and copies produced on a reader-printer.
- Samoan documents on microfilm. *Unesco Bul Lib* 18(4):194[265], July/Aug. 1964. Program for microfilming documents of interest to scholars is carried on by University of Hawaii Library.
- SANS, E. W. and ORTON, A. W. Visualizing in color—through diazo. *Reprod Engr* 8(4):124-25, 140-41, Apr. 1964. Discusses the overhead projection of slides and the reproduction of copies in applications of the United Air Lines.
- Seagoing University (University of the Seven Seas). *Reprod Methods* 4(1):59, Jan. 1964. Microfilm has been selected as an active ship's library teaching aid.
- SHARP, Q. 35 mm microfilm applications. *Reprod Methods* 4(4):42-43, 61, Sect. 1, Apr. 1964. Cites several applications and gives cost figures.
- SHEPARD, B. D. Copying methods as applied to library operations, 1964. Thesis (M.L.S.) University of Mississippi.
- SWENSON, J. P. EKG copies save time, speed treatment. *Reprod Methods* 4(9):30, Sept. 1964. Use of the Xerox 914 for copying of electrocardio-

grams as well as for articles from journals and preparation of offset masters.

VEANER, A. B. High speed reproduction of library cards through microreproduction techniques. *In: Proc National Microfilm Assn.*, 13:1964.

— and FRASER, J. Library card reproduction by Xerox Copyflo. *Lib Res & Tech Serv* 8(3): 279-84, Summer 1964.

Writing and reading for the paralysed. *Unesco Bul Lib* 18(1):45, 48[53], Jan./Feb. 1964. Describes microfilm work being done by the Committee for Writing and Reading Aids for the Paralysed.

SYSTEMS

BISHOP, C. E. Micro processing—new route to economy for re-draw procedures. *Reprod Engr* 8(8):263-64, 284, Aug. 1964. Describes a microfilm aperture card system for drawings having a number of viewers placed throughout the plant.

BLOOMFIELD, M. This works for us: Telephone answering recorder and reproduction service. *Spec Lib* 55(9):632, Nov. 1964. An automatic telephone answering tape recorder called Electronic Secretary installed by Hughes Aircraft Co. Culver City Library acts as the link between patron and reproduction service.

Blueprints by wire; long distance Xerography. *Product Eng* 35:47-48, June 8, 1964.

BONK, E. T. How to communicate computer print-out by reproduction methods. *Reprod Rev* 14(7): 30, 32+, June 1964. Examines ways in which certain reproduction processes can extend the usefulness of computer operations.

BROWN, A. N. Microfilm and video speed customer information. *Elec World* 162:64-66, July 27, 1964.

BURLEIGH, W. P., JR. Basic guide lines for setting up an engineering drawing microfilm program. *In: Proc National Microfilm Assn.*, 13:1964.

City of L. A. microfilms drawings and records. *Reprod Methods* 4(4):44-45, 48, Sec. 1, Apr. 1964. System included microfilming of maps, drawings, records and distributing prints to dispersed locations.

Computer/repro system speeds operations for Westinghouse Division. *Reprod Methods* 4(4): 38-39, 48, Sect. 1, Apr. 1964. Combines electronic data processing concepts with a Xerox Copyflo—unitized microfilm system.

Document Transmission by Closed Circuit Television (Marconi Company, Basildon, Essex, England). *Aslib Proc* 16(8):230-31, Aug. 1964.

Employee suggestions filmed for reference (Eastman Kodak). *Admin Mgt* 25(7):64-67, July 1964. About 25,000 suggestions are handled annually in a system that makes use of microfilm, IBM punched cards, and a Simplex numbering machine.

EVEN, A. Continuing analysis of basic steps in mechanized data retrieval. *Reprod Methods*

4(10):16, 18, 20, 62, Oct. 1964. Discusses basic steps of data processing and describes cards as the microfilm carrier.

GAUL, A. E. Pick a photo with a "Kwic" system. *Reprod Engr* 8(6):201-02, 214-15, June 1964. In a semi-automated system at University of California's Lawrence Radiation Laboratory key words are selected from the photograph's caption to produce an index.

GOFF, F. L. Microfilm "unitizes" engineering data—for successful satellite shoot. *Reprod Engr* 8(8):267-68, 286, Aug. 1964. Describes system using microfilm aperture cards and a Xerox 1824 printer.

HERRICK, C. Photolisting systems—what they do; how they do it. *Reprod Rev* 14(9):48, 50+, Sept. 1964. Discusses the preparation of lists when the information on cards is assembled and photographed by a sequential-card camera. The manual, mechanical and photographic operations are described.

JENKINS, D. Automated document information storage and retrieval. *Systems* 5(3):39, 42, 44, May/June; (4):45, 50-51, 60-61, July/Aug.; (5):42, 44, 46-48, Sept./Oct. 1964. Review of commercially available systems making use of the roll microfilm concept: CRIS, FMA-Filesearch, MIRACODE, MEDIA, FILMOREX, MAGNAVUE, RADIR, and others.

LEIDER, A. Modern systems of information storage and retrieval. *Am Water Works Assoc J* 56: 569-74, May 1964.

MCARTHUR, D. W. Microfilm systems: Tool for data storage and retrieval. *Systems* 5(2):35, 46, 48, Mar./Apr. 1964.

Microfilm means security. *Reprod Methods* 4(12): 49, Dec. 1964. Describes a system in use at Koehler Mfg. Co., Marlboro, Mass., in which microfilmed drawings are mounted on 3- x 5-inch index cards.

NATHANSON, H. New microfilm technique cuts lead time at TMC (Technical Material Corporation, Mamaroneck, N. Y.). *Reprod Methods* 4(6): 40-41, 52, June 1964. Describes a system which includes the 3M Co.'s Filmsort 1000d Processor-Camera.

REVES, H. F. Produce information fast and now—through data processing. *Reprod Rev* 8(5):157-58, 174+, May 1964. Describes a system in use at General Dynamics/Electronics that permits 16mm or 35mm microfilming of the EDP output and also prints a page size copy of microfilm image.

SAAMA [San Antonio Air Material Area, Kelly Air Force Base] tests new procurement concept. *National Micro News* (71):21-28, Aug. 1964. Describes an aperture card system for engineering drawings with test results that indicate economy and advantages.

STINE, L. G. Random retrieval of micro-image parts. *In: Proc National Microfilm Assn.* 13:1964.

TANNIAN, P. A. and CORTIS, A. C. Fast, faster, fastest for Ford. *Reprod Methods* 4(12):45, Dec. 1964. Describes a unitized microfilm—aperture card—rapid printout system.

TAUBES, E. P. Electronic data retrieval and microfilm. *In: Proc National Microfilm Assn.* 13: 1964.

Videofile system substitutes TV recordings for file folders. *Reprod Methods* 4(11):49, Nov. 1964. "Videotape" has been introduced by Ampex Corp. and will be first delivered to NASA, Huntsville, Ala. The system consists of a Videotape recorder with electronic editing capability, TV camera, indexing unit, television receiver, and/or electrostatic printer.

WILLIAMS, J. A. Organize the details for efficient data control. *Reprod Engr* 8(6):197-98, 216, June 1964. Describes the handling of drawings at Bendix Corp., Indiana, using aperture cards and Xerox equipment.

WOLF, D. R. Microfilm topics: Communications Center operations. *Systems* 5(5):39, 41, Sept./Oct. 1964. Describes system for incorporating technical information into the 3M Technical Communications Center by means of the Filmsort 1000d Processor-Camera and Filmsort aperture cards.

STANDARDS

ASHTON, G. Why the urgent need for an international microfiche standard. *Reprod Methods* 4(9):20, 26, Sept. 1964. Discusses sizes of microfiche in use and refers to paper by W. R. Hawken, *National Micro News* (69):195-207, Apr. 1964.

HAWKEN, W. R. Technical reports on microfiche—what price unitization? *National Micro News* (69):195-207, Apr. 1964. Discusses the proposed

standard formats of 3 x 5, 4 x 6 and 5 x 8 inches in size and makes a recommendation.

International standardization of microfiche discussed at ISO Budapest meeting. *Microfiche Foundation Newsletter* (Delft) (7):1-2, Dec. 1964. Meeting of the NMA Committee on Quality Considerations of Permanent Record Microfilm held at the National Bureau of Standards June 5; June 25, 1964. *National Micro News* (70): 265-70; 71-73, June 1964.

Microfiche standards adopted. Three government agencies adopt standards to speed up, simplify, dissemination of R & D reports. *Chem Eng News* 42(35):54-55, Aug. 1964.

PELCOWA, J. Polish standards for microfilm. *Rev Int Doc* (The Hague) 31(3):111, Aug. 1964. (In French.)

PIEZ, G. T. Library Technology Project Report: Microfiche standard adopted. *Spec Lib* 55(6): 390, July/Aug. 1964.

RUBIN, J. An historical survey of line density approach to exposure control. *Reprod Methods* 4(4): 33-37, 59-60, Sec. 1, Apr. 1964. Discusses the DOD specification MIL-M-9868.

RUTKUS, J. Microfiche specification review for auto-viewing and printing. *In: Proc National Microfilm Assn.*, 13:1964.

Standardization of the microfiche. *Microfiche Foundation Newsletter* (Delft) (5):3-4, June 1964.

EDITOR'S NOTE: Volume 13 of Proceedings of the National Microfilm Association from the NAM Convention in Philadelphia, April 28-30, 1964, had not been published when this was compiled; therefore, page numbers in pertinent above references are lacking.

Revision of Copyright Law

The bill for the revision of the United States copyright law (S. 1006 and H.R. 4347) was introduced in the 89th Congress on February 4. Of main interest to librarians and others in the information field is the statement of fair use, which is not in the original law. The bill states, "Notwithstanding the provisions of section 106, the fair use of a copyrighted work is not an infringement of copyright." Section 106 on the exclusive rights in copyrighted works is primarily concerned with the reproduction, distribution, and sale of several copies of the work. Provisions in the bill as changed or not covered in the original law are: 1) establishment of a single system of statutory protection for all works, published or un-

published; 2) instead of copyright for 28 years, the term is for the author's life plus 50 years; 3) after 35 years the author or his heirs may disclaim copyright; 4) sound recordings will be protected; 5) present compulsory license for music recordings will be modified; 6) removal of the exemption of public performances of nondramatic literary and musical works where the performance is not for profit; 7) exemption of juke box operators from payment of royalties; 8) omission or errors of copyright notice does not forfeit copyright; and 9) modification of clause that certain works must be manufactured in the United States to have copyright protection here.

Flow Chart on Library Searching Techniques

SALLY SWENSON

WITH SO MUCH activity in large libraries being geared towards mechanization these days, involving as it does the logical analysis of operations by flow charts and block diagrams, there is developing a new, coordinated approach to library activities from which smaller libraries can benefit now. Smaller libraries have the opportunity to plan their operations and develop their services in a more logical, systematic manner, which could lead them more easily to fully integrated, electronic systems in the future.

The flow charting process is an extremely useful tool for a variety of library operations, whether or not mechanization is in view. At Northern Electric's Research and Development Laboratories, we began with a general enthusiasm for the method of flow charting and an awareness of a real need to communicate effectively to our 600 users what the library can mean to them. It seemed appropriate to attempt a generalized flow chart of the entire library as a start. Since the chart is aimed at our users, it is called a Flow Chart of Library Searching Technique, but it will quickly be seen that this chart is a general statement of the library's resources, with related index and search aids indicated.

The chart consists of three main parts:

Part A: Steps 1 to 3, upper left

Part B: Steps 4 and 5, center

Part C: Steps 6 to 12, lower right

The steps in part A will be readily recognized as those decisions a librarian makes almost unconsciously when beginning a search—a subconscious activity that is one of the most significant contributions librarians make in the information handling process. The chart endeavours to expose the nature of this activity and pass the technique along to library users for their benefit. As

Miss Swenson is the Chief Librarian of the Northern Electric Co., Ltd., Research & Development Laboratories, Ottawa, Canada.

progress through part A is based on knowledge of the extent, organization, and quality of available publications, which is not second nature to the average library user, these basic steps assist the user in defining the terms of reference for his search. The library user should be able to conduct his own search, when he so desires, following this logical path, and as he gains experience in defining his needs in relation to the illustrated organization of the literature, he will learn to satisfy his own highly specialized information requirements. The user is advised not to proceed further if he cannot frame his question as suggested in part A. Here is an example of the type of clarification to be achieved by steps 1 to 3:

Undefined Question: Looking for something on computers in libraries.

Definition Steps

- Step 1: Use of computer at National Library of Medicine, for preparation of index journal. All available literature from 1963 on.
- Step 2: Books, periodicals, technical reports, bibliographies, conference proceedings.
- Step 3: Don't know any authors, try subject approach or source (also General Electric) and look for authors in references.

Part B is the heart of the system, where the full range of available publications is displayed for selection, with suggested alternate approaches. The related subsidiary publications, shown to the right of each of the main types of publication, offer specific

FLOW CHART OF LIBRARY SEARCHING TECHNIQUE

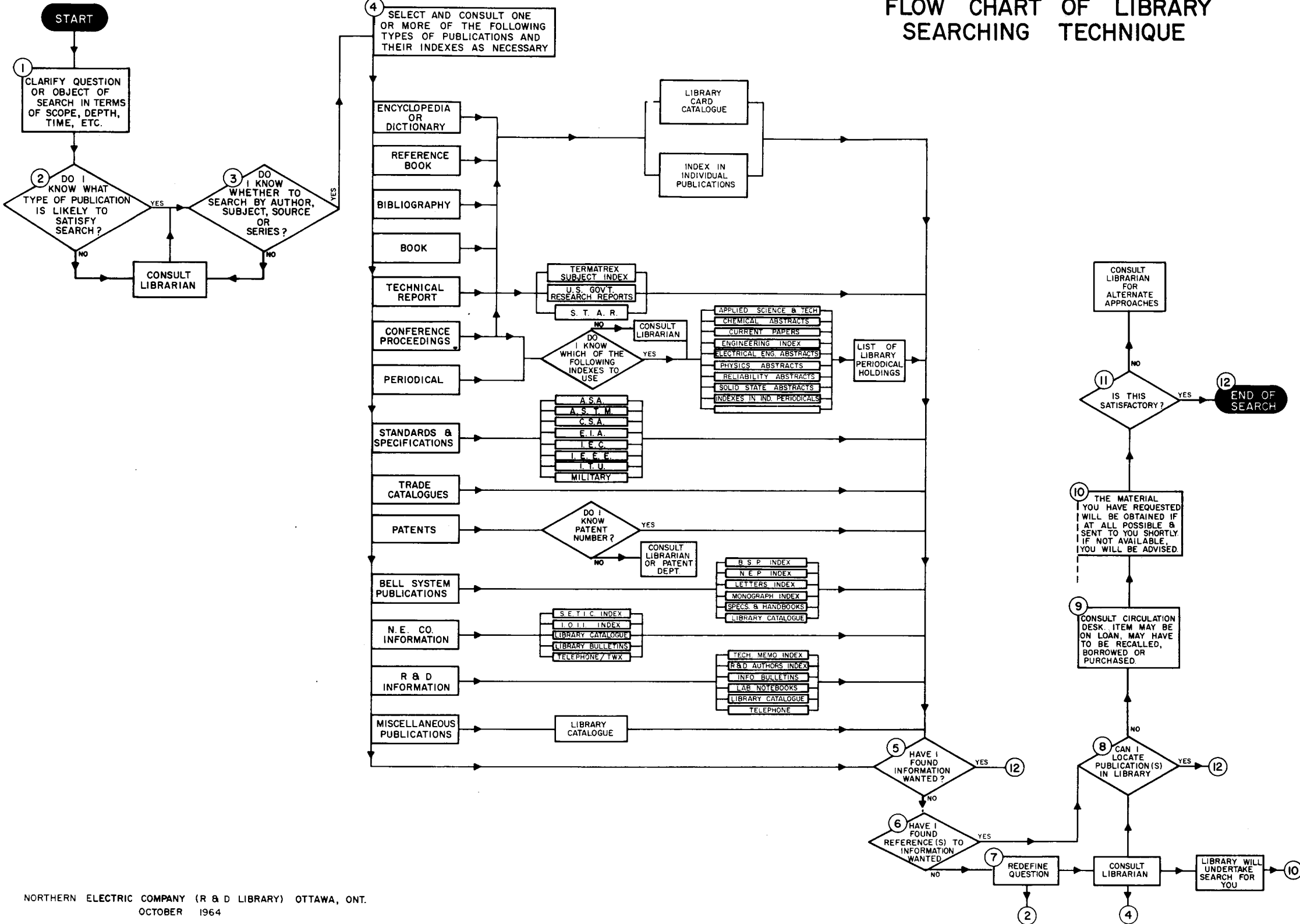

NORTHERN ELECTRIC COMPANY (R & D LIBRARY) OTTAWA, ONT.
OCTOBER 1964

suggestions for conducting a specific search. While we have tried to keep this chart as straightforward as possible, the fourth step is obviously complex if tackled directly. If the searcher has not successfully completed the first three steps, he is unlikely to be able to cope efficiently with this step. However, having progressed through the preceding three steps, the searcher should be able to proceed confidently and rapidly through the fourth.

In the final part of the chart, the user is offered various suggestions and alternatives if the answer to question 5 is "no." Here the library staff may help locate an item, advise on further search tactics, or take over the search for the user, depending on his wants at this time.

The chart has been surprisingly well received by our scientific staff, most of whom are engineers accustomed to formal programming and scheduling techniques. It talks to them in a manner they understand, revealing the array of resources at their disposal. One of its most useful applications has been as a teaching aid in library orientation lectures for new members of the laboratories staff. Each type of publication shown on the chart is described from a user's viewpoint as to acquisition policy, coverage, quality, organization, and indexes. In many cases, the indexes themselves are displayed and described. Because the chart presents information in a visual way, more can be said about specific publications and their organization without the lecture becoming too complex.

This is the second issue of our chart, incorporating some additions and improvements over the first one. Even so, it is incomplete and imperfect, since it reflects the present state of a young library, and this, of course, makes it a very helpful planning tool. Gaps and deficiencies in the system become evident, lines of development are suggested, and on the warning side, illogical operations are illuminated. The R & D Library is in the process of doubling its present space, and once this expansion has been completed, we intend to reissue the chart, showing location numbers in each box corresponding to physical locations on a map of the library as a further guide to users.

SPOTTED

- Even libraries have strange bed-fellows. According to the New York "Times" the entire Asbury Park Police Department became members of the Friends of the Asbury Park Library
- Cincinnati has initiated Machine Tool Week, a novel, original, and informative promotional project for the city's biggest industry. The brainstorm of SLA member Mrs. Dorothy McNutt, and sponsored by the Public Library of Cincinnati and Hamilton County during February 8-13, the activities began with Ohio's Governor James Rhodes cutting the official steel ribbon with, of course, a machine tool.
- The Space Technology Laboratories Library at Redondo Beach, California, is enthusiastically playing den mother to a pack of Space Scouts—45 boys and 12 girls—who participate in an Explorers' program of space science. A STL executive was heard to proudly announce, "This is probably the only technical library in America that young people can go into."
- Here is a challenging comment on scientific information and retrieval: Sometimes it's quicker to do the research over again than it is to find it!
- In a series of U.S. Department of Health, Education, and Welfare financial charts from the Office of Education, 1965 was a banner year for financial assistance to library services—\$55 million. From 1961-64 \$7.5 million was spent. The first allocation in 1957 was \$2 million.
- Parents unite! Get the school library your child needs with the help of the American Library Association and the International Paper Company. IP has prepared a kit full of facts, statistics, forms, and ideas, divided into four strategic moves: find out where you stand; get professional help; devise a plan of action; and follow through. IP has also embarked upon an advertising campaign to stimulate public interest and support for more school libraries.
- A research librarian in the Technical Library is the cover girl on the January-February 1965 "Better Living," the employee magazine of E. I. duPont de Nemours. The cover story, "An Answer for Every Question," tells in text and unusual photos of other hard-working glamour girls who search, translate, abstract, index, and answer a multitude of questions.

Is This a Problem? ? ? ?

This is the first of a proposed new series of short features that will present in narrative form typical administrative, personnel, and management problems in special libraries. By utilizing the "case history" approach it is hoped that readers will be stimulated to think through their own solutions to the problems posed. Written comments on ways of resolving the problems will be published as "Letters to the Editor;" solutions to this first "case" should be submitted by May 7 for inclusion in the July-August issue. The series is being prepared by Louis Stoops, Librarian, United States Steel Corporation, New York City. The author, editor, and members of the Special Libraries Committee also welcome comments on the series itself as well as suggestions for future "case histories."

A special librarian named Mary Jo worked in a large company, the RB Corporation, manufacturers of reversible batting. She had been employed to take charge of a brand-new library, with excellent facilities, new equipment, and a view from five large windows. Mary Jo had a Master's degree in Library Science and eight years' experience in a public library plus three years in a special library in the statistics field. The subject area of the RB Corporation Library was mainly management, business and finance.

The library staff consisted of four young women. The number one girl, Susan, was a college graduate, and Mary Jo had hired her. Her number two girl, Jean, was a high school graduate. Elsie and Pat were hangovers from the good old days, when the Personnel Department of RB did not know what to do with inheritance people (their dads had worked for RB), and a library seemed such a good place for people to work—it was quiet and non-taxing.

Mary Jo had been hired as Librarian and introduced to Jean, Elsie, and Pat, as "your new boss." Mary Jo felt hackles rising on her three assistants and instinctively and impulsively asked them all to go out to lunch with her. Afterwards she talked to each one outlining her plans and their new responsibilities.

Jean had always done the filing, so Mary Jo thought that she should continue to do so, but a new subject filing system had to be set up, and separate files would be maintained for the company and its personnel. Elsie was given the job of checking in and routing the library's 400 magazines, and Pat was given responsibility for the rather broad area of book ordering, processing, and binding.

However, problems soon developed for Mary Jo. She found that she could not give adequate reference service to anyone, for she was constantly dividing her time between devising new subject headings, ordering books, scanning periodicals, and teaching Susan where to find answers to reference questions. Since checking periodical cards proved too much for Elsie, Mary Jo assigned this task to Pat, who promptly let the book ordering and binding lapse. Pat had proved disappointing because she did not want to learn anything about book ordering and thought "the CBI was a big bore." Jean was slow on the filing and had a memory like a sieve.

Mary Jo, at her wit's end, asked for help from her boss. He shook his head. "You have plenty of help," he said. "Plenty."

"In numbers, yes," retorted Mary Jo, "but these people are untrained and even simple office procedure throws them."

"Never had any complaints before," said the boss.

"This was not a library before," shot back Mary Jo.

And so they wrangled.

• • •

The problems of dealing with ready-made staffs, training them, and developing and maintaining follow-through and continuity is a MUST for any special library. Mary Jo feels that her boss expects too much of her by burdening her with unqualified people. Her assistants are all married, and she can always hope they will leave to have children, but this hope does not get the filing done, the magazines checked in, routed, and bound, the reference questions answered, or the catalog cards typed and filed.

Is this your problem?

URBANDOC: A Cooperative Project of Librarians and Planners

URBANDOC is a project to control the vast literature of urban planning and renewal by developing a computerized system for retrieval of information. The enormous amounts of published material in this area of knowledge, coupled with the fact that not enough is being done to bibliographically control it, creates a real problem in library work. Can the use of electronic data processing equipment help librarians assimilate the literature of urbanism? URBANDOC is a study of the feasibility of using computer techniques in this area of social science librarianship.

What later became URBANDOC had its origins at the 1963 SLA Convention in Denver, at a Planning, Building, and Housing Section open house where Vivian Sessions and Wayne A. Kalenich started exploring a potential project in the social sciences, which led to an arrangement for IBM cooperation. (Mrs. Sessions is the librarian of the City Planning and Housing Library, a unit of the New York Public Library, and Mr. Kalenich is an information retrieval specialist with IBM's corporate headquarters at Yorktown Heights, New York.) Since the literature of city planning is so multitudinous and, to make matters worse, so difficult to locate, a project such as this sparked the interest and cooperation of the librarians at the Section's open house.

The next step was taken at the Council of Planning Librarians' (CPL) Convention four months later. This Convention was held jointly with the American Institute of Planners' (AIP) Convention. At a Joint Workshop on the Library as an Information Center for Planners, AIP's prestigious Edmund Bacon (Director, City Planning Department, Philadelphia) delivered a mandate: let there be an AIP-CPL workshop to sponsor the development of a national information system; let there be a presentation of the national information system at the following annual convention; let Vivian Sessions coordinate the system.

Although no organization existed to implement the directive at the time of its delivery, the reputation of Mr. Bacon, combined with the logic of the situation, enabled a New York group to assemble the necessities: financial assistance from the Taconic Foundation, computer know-how from IBM, library materials from the City Planning and Housing Library, planners from the New York Chapter of AIP, librarians from planning libraries in New York and Chicago, and over-all support from the New York City Department of City Planning and its commissioners. (The librarians in this task-force, all SLA'ers, were: Joseph Benson, Municipal Reference Library of Chicago; Howard B. Bentley, Time, Inc.; Clifford R. Johnson, Ford Foundation; Sarah H. Smith, Regional Plan Association, Inc.; Eve Thurston, New York Public Library, Municipal Reference Library; Barbara C. White, then with the Tri-State Transportation Commission; and, of course, Vivian S. Sessions.)

The Taconic Foundation granted the funds to make a study in which 200 documents would be put into an IBM machine system. And so in January 1964 this small group of special librarians began to prepare the program and the procedures for selecting, organizing, and analyzing the 200 documents. Many hours throughout the winter and spring were spent developing this project, and at nights and on weekends the librarians and planners worked long hours in unheated offices, eating sent-in food, to ensure the successful birth of the project.

A special controlled vocabulary was built by the librarians just for this project. Special cataloging rules of entry were adapted. A geographical code was adopted. And cataloging and classifying continued apace.

The summary of the activities and findings of the group, which in the spring of 1964 named itself and the study URBANDOC, was given on schedule at the annual joint Convention of the AIP-CPL in Au-

gust 1964. The presentation met with great enthusiasm and interest, and the mandate was increased: let every effort be made to make URBANDOC a continuing project. (A report that discusses the methodology and goals of URBANDOC is: *URBANDOC, a Report on Computerized Documentation and Information Retrieval in the Literature of Urban Planning and Renewal*, by Vivian S. Sessions, Project Director. New York: Institute of Public Administration, 1964. Available free from the City Planning and Housing Library at 2 Lafayette Street, New York City. Press coverage may be seen in: *New York Times*, August 16, 1964; *Barrons*, November 2, 1964; and the *SLA New York Chapter News*, February 1965.)

At this writing, the URBANDOC study is being considered for a Demonstration study in the Federal Urban Renewal program. It would continue in New York City under the direction of Mrs. Sessions.

Basically, URBANDOC is like any other library operation: it has input (selecting documents, cataloging and classifying documents, storing the resultant records in a catalog—in this case a magnetic tape for an IBM 1401) and output (finding the needed information for the requestor). The only difference is the specialness of the subject matter and possibly the catholicity of documents—books, periodical articles, pamphlets, Congressional hearings, newspaper clips, press releases, maps, and so on.

Like every other computerized project, URBANDOC has the concomitant worksheets and print-outs for main and added entry and title. Subject print-outs are generated on demand and in answer to specific requests. Such a print-out gives not only a bibliographic reference but also an abstract of each reference. A fringe benefit here is that each reference-abstract contains the tracings to all the descriptors, or subject headings; thus giving a sense of the coverage or point of view of each reference. Another interesting element is the geographical one. URBANDOC treated geographical areas as descriptors so that retrieval is possible in the same way as is subject retrieval. This geographical ability of URBANDOC is proving to be one of its more important aspects

because much research is done on the basis of *where*, as urban planning always occurs in a definite place.

If the projected Demonstration study of URBANDOC indicates intellectual and economic feasibility to provide information otherwise unavailable, and if this data be of aid in the planning of our urban areas, then it is likely that in the future URBANDOC will be more and more essential and will encourage other projects of this type.

HOWARD B. BENTLEY, Library
Time, Inc., New York

I HAVE READ the URBANDOC report and although I have not had the opportunity to see a demonstration of its use, feel that it can be of great use to the planning profession and those undertaking research in the field.

A practicing planner today has to make it his business to at least peruse and be aware as much as he can of the vast volume of written material in the form of books, articles, and reports being issued. Most publications are noted and then passed on to the library for availability when needed. A few are retained for reading. Most careful attention is given to professional publications and those known by the reputation of their authors to be of most significance. Finding pertinent materials later is what presents difficulties, even in a small library, because in a field as broad as planning there is great necessity for cross-referencing.

To my mind, the greatest value of URBANDOC is in the abstracting of the original references, so that its contents and significance can be quickly appraised and can be indexed under the proper subject heading. This, I gather, may also prove to be the most expensive part of the task as it requires people trained in library science with a good knowledge of the planning field. In fact, even if we didn't have URBANDOC, we could make very good use of good abstracts of new works printed on library cards and in enough quantity to permit their cross-filing in a card catalog. The American Institute of Planners has been seeking funds for years to establish such an

abstracting service, so we welcome it even if it takes fascination with the computer to induce those able to give financial support to this venture.

However, there is no question that the computer lends a dimension to this process that could not be achieved by other means, namely that of rapid retrieval. I would imagine that the installation required for proper use of this method of retrieval will be limited by expense to major libraries or institutions in central locations. It would, therefore, be most helpful if print-outs of filed abstracts could be sold to smaller organizations either in punch card form or for hand filing in an office library (which is what URBANDOC plans to do). I also hope that techniques will be developed to sift out and discard references that are outdated or no

longer of significance. Like every other field, planning has its accumulations of printed material which should be gracefully retired.

My own procedure in research has been to seek first the latest works on a subject by the most qualified people or agencies and to then use their bibliographies as a source for further references.

Even the best abstracts are no substitute for thoughtful study, which may lead one's investigations into very different directions than one's preconceptions in approaching a subject. To put it another way, URBANDOC should prove to be a very useful tool, which will aid but never replace the intelligent researcher.

RICHARD MAY, JR., A.I.P.
Raymond & May Associates
White Plains, New York

Join the Ranks of NLW Promoters!

Federal Reserve Bank of Minneapolis

THE LIBRARY entered into the spirit of National Library Week by bringing its services to the attention of its patrons, both within and outside the bank. Descriptive brochures were mailed to nearly 500 member banks in the Ninth Federal Reserve District. Since each bank has at least five or more employees, at least 2,500 bank officers and employees were made aware of NLW and of the bank library in particular. Brochures were also mailed to other special libraries and to other Federal Reserve System personnel throughout the United States.

Over 600 employees of the Bank itself including those from the branch at Helena,

Montana, received a descriptive folder and an invitation to our week-long Open House. Employees of the National Bank Examiners and the Federal Deposit Insurance Corporation were also included in the celebration.

For the Open House, our quarters were decorated with mobiles, posters, streamers, and book displays as well as an attractive bulletin board that depicted "Keys to Economic Research." Visitors were given our brochure, a bookmark, and a candy bar. An estimated 250 people signed the register and learned more about our library.

Our monthly, "The Book List," invited our own staff to visit the library. We also made large invitations in the form of a key and placed one on the bulletin board of each floor in the bank. Library patrons from local banks and business firms were also made welcome.

An article "Reading Is the Key" appeared, with pictures of our library and its staff, in the May 1964 issue of *Columns*, our employee publication.

The library staff, which consists of two professionals and two library assistants, was most pleased with the enthusiastic response to our NLW efforts. Management encour-

SPECIAL LIBRARIES

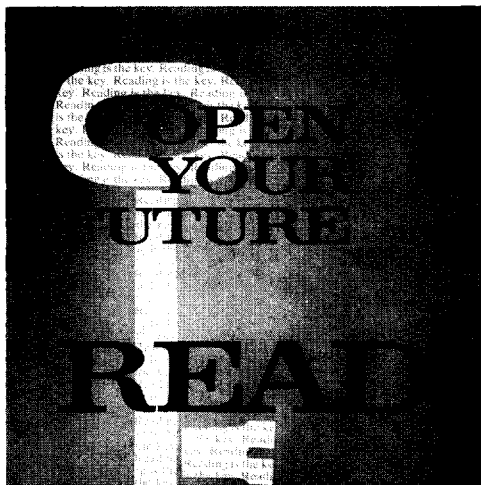

aged us in our plans, and all concerned showed real interest and cooperation. By reaching an estimated audience of 2,800, we anticipate renewed interest in the library and an increase in the use of our facilities.

MILDRED R. STRAND, Librarian

Minneapolis-Honeywell Regulator Company

WE USED Reading Is the Key posters—all three types—as eye-catchers on bulletin boards in various sections of the Engineering Library. In front of a glass window, recently acquired books were on display, and since these windows opened toward a hall, the impact was double that of an exhibit facing into the library.

Our biggest effort was a one-week drive to orient all engineering personnel in the use of library tools. We circulated a memo to all departmental managers asking for their cooperation in encouraging participation by all interested personnel, especially new employees or ones for whom we didn't have a library card. Our drafting department made large placards with visual information about the library, such as guides for using the card catalog. We encouraged library card registration and prepared giveaways such as the *Guidebook to Using the Engineering Library*.

Seventy-eight engineers (90 per cent had never used the library before) toured the library. At least 11 signed up for library cards; three asked for literature searches; and all have since dropped into the library to do some browsing or searching of their own. Several engineers not included in the original tour have asked to be included in later sessions.

JOANNE NORDSTROM, Librarian

To help librarians and editors promote NLW in company publications, Alvin C. Eurich, President, Aspen Institute for Humanistic Studies, Aspen, Colorado, has written "The Ideal Consultant: Your Business Library," available gratis from Association Headquarters. Descriptions of company library resources and services may be added for a more individual touch.



Know what you're talking about

READ

Participate in NLW 1965

With National Library Week just around the corner, it's time to translate your ideas into activities. And while you have the art department busy with your brainstorming and your assistant busy clearing a display area, why don't you make the decision to compete for the SLA National Library Week Publicity Awards—first prize \$75, second prize \$25—donated this year by the Ford Motor Company. If you win, your Chapter treasury will be swelled by your efforts.

1. You may enter either as an individual library or as a Chapter.
2. The ideas must come from the library staff or Chapter, although other departments may help in the preparation of exhibit materials.
3. The visual material should be accompanied by six copies of a two-page (maximum) typewritten description of the project.
4. Clippings, photographs, and promotional pieces should be mounted on 8½ x 11 white or colored paper.
5. DEADLINE: May 20, 1965.

Complete details about SLA's NLW Publicity Award appear in the February 1965 issue of "Special Libraries" on page 129.

Rebecca B. Rankin: In Memoriam

OF REBECCA BROWNING RANKIN, who died on March 1, 1965, at Dobbs Ferry, New York, just one month prior to her 78th birthday, it is said that despite the fact she was born in Piqua, Ohio, and reared in Illinois, she probably knew more about New York City than anyone. A faithful and hard working public servant, an invaluable asset to all New York City officials for 34 years, Miss Rankin will be sorely missed by all who were privileged to know her.

Miss Rankin, who was characterized by the late Mayor LaGuardia as a "human index to New York City affairs," served as head of the Municipal Reference Library from 1920 until her retirement in 1952. Although a part of The New York Public Library, the Municipal Reference Library was actually created as a special library designed to aid City officials who needed facts to do their jobs. Under Miss Rankin's expert guidance, the Municipal Reference Library soon became the center of municipal information. In fact, Miss Rankin considered her library work as an avocation instead of a vocation, and everyone who had the good fortune to talk with her was soon enveloped with her enthusiasm for the profession.

In spite of her enormous contributions to special libraries, she never failed to improve and enrich the public library field as well. Miss Rankin, who was graduated from the University of Michigan, received her training as a librarian at the Library School of Simmons College in Boston. In 1918, while vacationing in New York and enjoying a well deserved rest from her job as librarian at the State Normal College in Ellensburg, Washington, Miss Rankin decided to visit The New York Public Library. Her visit turned out to be a long, successful and rewarding 34 years with this great institution. During those years, she made every City official from the Mayor down keenly aware of the purposes, uses, and values of the Municipal Reference Library. In truth, she brought the library with its vast storehouse of specialized information to the desk of each City official.

Nor were Miss Rankin's contributions to the library and information fields limited to the City of New York only. During 1922-3, Miss Rankin served as President of Special Libraries Association and a decade later as its Secretary, at which time she organized the headquarters of the Association in New York City and proceeded to establish the position of a full-time paid secretary for the organization. She was also President of the New York Library Association in 1941 and instrumental in publishing a manual for this organization. During her 33 years as an active member of the library community, Miss Rankin participated in virtually every type of professional activity and served as chairman of many committees in many library associations, especially the Special Libraries Association, which honored her contributions by selecting her for the first SLA Hall of Fame in 1959.

Miss Rankin's natural interest and abilities in the field of information retrieval and dissemination resulted in pioneering efforts on her part for the archives and records management professions. She was instrumental in establishing the Mayor's Municipal Archives Committee in New York City and served as its first Chairman. This Committee successfully launched a city-wide archives and records management program which today is among the largest and most efficient in the nation. During this period, she also persuaded the Mayor at a hearing of a Charter Revision Commission that librarians were entitled to be included in a pension and retirement system supported by the City. Her reasons quickly brought about the desired results for which every librarian in the City's library system is deeply grateful.

It is not possible to include all the innumerable contributions Miss Rankin has made in the city government. Her passing is not only a great loss to officials and citizens alike of New York City, but it will be deeply felt by librarians everywhere. We are all happier and richer for having known her.

JAMES KATSAROS, Administrator
Municipal Archives & Records Center
New York City

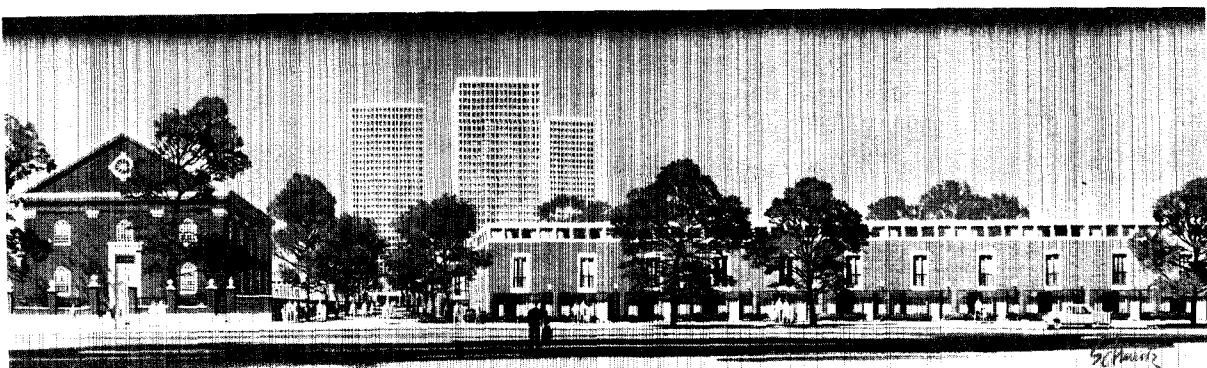

Lawrence S. Williams

Philadelphia, the seat of early independence, is at present a forerunner in urban renewal. Society Hill Towers, in background, overlook, at the left, the former St. Paul's Church, now the home of the Episcopal Community Services, Diocese of Pennsylvania, and on the right, the new Third Street town houses. The over-all artist's view is of Washington Square East.

56th SLA Convention Program

Benjamin Franklin Hotel

Philadelphia, Pennsylvania, June 6-10, 1965

Theme: Library Cooperation—Key to Greater Resources

SATURDAY, JUNE 5

Board of Directors Meeting: 9:30-5:00 p.m.

SUNDAY, JUNE 6

REGISTRATION: 9:00 a.m.-6:00 p.m.

Board of Directors Meeting: 9:30 a.m.-noon

Biological Sciences Division: 10:30 a.m. Executive Committee closed meeting

Afternoon

Incoming Chapter Officers and Bulletin Editors Meeting: 1:30-4:30 p.m.

Incoming Division Officers and Bulletin Editors Meeting: 1:30-4:30 p.m.

First Conventioneers Reception: 4:00-5:00 p.m. Division Chairmen hosts

Evening

RECEPTION IN EXHIBIT HALL: 6:00-8:30 p.m.

Division and Section Open Houses: Advertising and Marketing, Biological Sciences, Business and Finance, Insurance, Museum, Picture, Publishing, Science-Technology, Petroleum Section (guests of Sun Oil Company), and Social Science, Planning, Building, and Housing Section

MONDAY, JUNE 7

Breakfast

Documentation Division: 8:00-9:30 a.m. Business Meeting

Science-Technology Division: 8:00-9:30 a.m. Advisory Committee closed meeting

Morning

OPENING SESSION: 10:00-11:30 a.m.

Presiding: William S. Budington, President, Special Libraries Association; Associate Librarian, The John Crerar Library, Chicago

Invocation: Henry J. Cadbury, Ph.D., Professor Emeritus of Harvard University, Haverford, Pennsylvania

Welcome: The Honorable James H. J. Tate, Mayor of the City of Philadelphia

Welcome from the Special Libraries Council of Philadelphia and Vicinity: President, Richard A. Davis, Assistant Professor, Graduate School of Library Science, Drexel Institute of Technology

Introduction of Convention Committee: Convention Chairman, Anne L. Nicholson, Librarian, Pennsalt Chemicals Corporation, King of Prussia

Summary of Exhibits: Exhibits Committee Chairman, John G. Daley, Instructor, Graduate School of Library Science, Drexel Institute of Technology

Keynote Address: Gordon R. Williams, Director, The Center for Research Libraries, Chicago, *Library Cooperation and Its Future*

Luncheon

Museum Division: Noon-1:30 p.m. **PRESIDING:** Jack S. Goodwin, Librarian, Museum of History and Technology Branch, Smithsonian Institution, Washington, D. C. Informal Swap Shop

Publishing Division: Noon-1:30 p.m. Business Meeting

Science-Technology Division

Petroleum Section: Noon-1:30 p.m. **PRESIDING:** George L. Aguirre, Librarian, Esso Standard Eastern Inc., New York City. **SPEAKER:** John H. Graham, Legal Division, Esso Research and Engineering Company, Elizabeth, New Jersey, *Foreign Patents, Their Acquisition and Control*

Social Science Division

Planning, Building, and Housing Section: Noon-1:30 p.m. **PRESIDING:** Mrs. Florence E. Johnson, Head, Technical Processes Department, Municipal Reference Library, Chicago. **SPEAKER:** Dr. B. T. McGraw, Assistant to the Administrator for Inter-group Relations, U.S. Housing and Home Finance Agency, Washington, D. C. *Minority Groups and Their Housing Problems*

SLA Translations Activities Committee: Noon-1:30 p.m. *Translations Problems and Solutions.* Open meeting. Speakers to be announced

Afternoon

GENERAL SESSION OF TECHNICAL PAPERS: 2:00-4:30 p.m.

MODERATOR: Rose L. Vormelker, presently on faculty of Kent State University and Western Reserve University; formerly Head, Business Information Bureau, Cleveland Public Library and Library Director, *Plain Dealer.* **SPEAKERS:** B. E. Lamkin, General Products Division, Development Laboratory, IBM Corporation, San Jose, California, *Applying a Set of Decision Tables to the Library;* Harry Baum, Technical Meetings Information Service, New Hartford, New York, *Measures for Predicting the Transient Value or Lasting Contribution of Scientific and Technical Meeting Papers;* Shirley W. Bolles, Technical Information Division, Esso Research and Engineering Company, Linden, New Jersey, *Use of a Mechanized Journal-Handling System in the Esso Research Library;* Michel O. Friedlander, Engineering Library, Grumman Aircraft Engineering Corp., Bethpage, New York, *Periodical Routing by Computer-Printed Labels;* and Stanley J. Slote, former summer consultant to Trenton (N. J.) Times Library while student at Rutgers State University Library School, *An Approach to Weeding Criteria*

Drexel Institute of Technology Graduate School of Library Science Alumni Reception: 6:00-7:00 p.m. Dutch Treat

Special Libraries Committee: 4:30-5:30 p.m. Manuscript rejections, authorship promotion, and subject appropriateness. Open meeting

Dinner

Advertising and Marketing, Business and Finance, and Publishing Divisions: 5:30-7:15 p.m. Cocktail hour and dinner. **PRESIDING:** Mrs. Ruth R. Braun, Chief Librarian,

The Detroit News. **SPEAKER:** Genevieve C. Hazzard, Vice-President, Campbell-Ewald Company, Detroit, *Who Is My Public in a Changing Market?*
Picture Division: 5:30-7:15 p.m. Dutch Treat cocktail hour and dinner
Association Past-Presidents: 5:30-7:15 p.m.

Evening

Newspaper Division: 6:00-7:30 p.m. Business Meeting
ADVISORY COUNCIL MEETING: 7:45-10:00 p.m.
Division Open Houses: 10:00 p.m. Business and Finance and Social Science

TUESDAY, JUNE 8

Breakfast

Museum Division: 8:00-9:15 a.m. Business Meeting
Picture Division: 8:00-9:15 a.m. Business Meeting
Science-Technology Division
Paper and Textile Section: 8:00-9:15 a.m. Business Meeting
Petroleum Section: 8:00-9:15 a.m. Business Meeting
Social Science Division
Social Welfare Section: 8:00-9:15 a.m. Business Meeting

Morning

GENERAL SESSION: 9:30-11:30 a.m. *Library Cooperation: Panacea or Pitfall?* **MODERATOR:** Samuel Sass, Librarian, The William Stanley Library, General Electric Company, Pittsfield, Massachusetts. **PANEL:** Charles R. Nelson, Nelson Associates, Inc., New York City; Dr. Richard H. Logsdon, Director of Libraries, Columbia University, New York City; and Scott Adams, Deputy Director, National Library of Medicine, Bethesda, Maryland

Luncheon

Biological Sciences Division: Noon-1:30 p.m. **PRESIDING:** Joan Titley, Chief Librarian, School of Medicine Library, University of Louisville, Kentucky. **SPEAKER:** John F. Stearns, Chief, National Referral Center for Science and Technology, Library of Congress, Washington, D. C., *The National Referral Center: A Key to Cooperation*
Insurance Division: Noon-2:00 p.m. Business Meeting
Military Librarians Division: Noon-2:00 p.m. **PRESIDING:** Charles R. Knapp, Chief, Library Branch, Industrial College of the Armed Forces Library, Fort Leslie J. McNair, Washington, D. C. **SPEAKER:** Thomas B. Dowd, Assistant Chief Scientist, U.S. Office of Naval Research, Boston Branch, *IRIA-ONR Cooperation with Government Contractors*
Museum, Advertising and Marketing, and Picture Divisions: Noon-2:00 p.m. **PRESIDING:** Jack S. Goodwin, Librarian, Museum of History and Technology Branch, Smithsonian Institution, Washington, D. C. **SPEAKER:** Dr. Anthony N. B. Garvan, Professor in American Civilization, University of Pennsylvania, *Museum Collections as Instruments of Historical Research*
Newspaper Division: Noon-1:30 p.m. **PRESIDING:** Rex M. Schaeffer, Library Director, Rochester (N. Y.) *Times-Union & Chronical & Democrat*. **SPEAKER:** Stanford Smith, General Manager, American Newspaper Publishers Association, New York City, *The ANPA Looks at the Newspaper Library*
Publishing Division: 12:15-1:15 p.m.
Science-Technology Division
Aerospace Section: Noon-1:30 p.m. Business Meeting
Chemistry Section: Noon-1:30 p.m. Business Meeting
Engineering Section: Noon-1:30 p.m. Business Meeting

Nuclear Science Section: Noon-1:30 p.m. Business Meeting

Pharmaceutical Section: Noon-1:30 p.m. Business Meeting

Social Science Division

Planning, Building, and Housing Section: Noon-1:00 p.m. Business Meeting. Open Meeting. PRESIDING: Mrs. Florence E. Johnson, Head, Technical Processes Department, Municipal Reference Library, Chicago. SPEAKER: John C. Poppeliers, Editor and Architectural Historian, Historic American Buildings Survey, National Park Service, Philadelphia, *Philadelphia: A New City of Old Buildings*

Transportation Division and Science-Technology Division, Public Utilities Section: Noon-2:00 p.m. PRESIDING: Wilmer H. Baatz, Librarian, Federal Aviation Agency, Washington, D. C. SPEAKER: William L. Rafsky, Executive Vice-President, Old Philadelphia Development Corporation, *Industrial Development Problems on an Area-Wide Basis*

Afternoon

Advertising and Marketing Division: 2:00-3:00 p.m. Visit to Picture Collection, The Free Library of Philadelphia; 3:00-4:30 p.m. Business Meeting. Refreshments

Biological Sciences Division: 2:00-4:30 p.m. Business Meeting

Business and Finance Division: 2:00-5:00 p.m. *Indexing: If H. W. Wilson Doesn't, Can We?* MODERATOR: Jo Ann Aufdenkamp, Librarian, Federal Reserve Bank, Chicago. PANEL: Charlotte Georgi, Librarian, School of Business Administration, University of California, Los Angeles, and Editor, *Literature of Executive Management*; Albert C. Vara, Librarian, Academy of Food Marketing, St. Joseph's College, Philadelphia, and indexer of food industry periodicals; Mrs. Lucille V. Craumer, Editor of H. W. Wilson's *Business Periodicals Index*, New York City; Eleanor H. Scanlan, Reference Librarian, Bureau of Industrial Relations, Graduate School of Business Administration, University of Michigan, Ann Arbor, and Managing Editor, *Michigan Index to Labor Union Periodicals*; Marjorie L. Holt, Librarian, John Hancock Mutual Life Insurance Company, Boston, and indexer for *Insurance Periodicals Index*; and Miriam H. Tees, Librarian, Royal Bank of Canada, Montreal, and associated with the *Index to the Royal Commission on Banking and Finance*

Geography and Map Division: 2:00-4:30 p.m. Visit to Nystrom Relief Map. Co., Philadelphia. HOST: Jack Marsh, Manager. Restricted to Division members

Military Librarians Division: 2:00-4:30 p.m. Business Meeting

Museum Division: 2:00-4:30 p.m. Visit to Philadelphia Museum of Art and Library and The Benjamin Franklin Institute

Newspaper Division: 2:00-4:30 p.m. *Newspaper Libraries and Cooperative Ventures.* MODERATOR: Mrs. Marian M. Orgain, Librarian, *The Houston (Tex.) Chronicle.* PANEL: William D. Chase, Librarian, *Flint (Mich.) Journal, A Public Library and a Newspaper Indexing Project*; Rose L. Vormelker, formerly Library Director, *The Plain Dealer*, Cleveland, *A Library School and a Course in Newspaper Librarianship*; Joseph M. Simmons, Librarian, *Chicago Sun-Times and Daily News, A Newspaper Library and Archives*; Mrs. Vera Halloran, Librarian, Bureau of Advertising, American Newspaper Publishers Association, New York City, *The Bureau of Advertising and the Newspaper Library*; Ann Minton, World Book Encyclopedia Science Service, Inc., Houston, Texas, *Science Information Services Can Cooperate with Newspaper Libraries*; and Harold G. Richardson, Librarian, Columbia Gulf Transmission Corporation, Houston, Texas, *Cooperation Can Start a Library*

Picture and Publishing Divisions: 2:30-4:30 p.m. *Picture Retrieval Systems, or "Where Did I Put That Picture?"* MODERATOR: Mrs. Helen Faye, Director of Art Editing, Harcourt, Brace & World, Inc., New York City. PANEL: Doris O'Neil, Chief, Life Picture Collection, Time Incorporated, New York City, *The TIME-LIFE Recordak System of Picture Indexing*; Mrs. Helen Faye, Director of Art Editing, Harcourt, Brace & World, Inc., New York City, *Is Picture Filing a Mystique?*, and Loretta J. Kiersky, Librarian, Central Research Laboratory, Air Reduction Company, Inc., Murray Hill, New Jersey, *Brainstorming Discussion on Picture Retrieval Systems*
Visit to Picture Collection, The Free Library of Philadelphia

Science-Technology Division

Nuclear Science Section, **Metals/Materials Division**, and Engineering Section: 2:00-4:30 p.m. *Cooperation Through Automation: The Future in the Nuclear Science, Engineering, and Metals/Materials Fields*. PRESIDING: J. Arthur Freed, Librarian, Los Alamos Scientific Laboratory, New Mexico. KEYNOTER: Dr. Albert I. Warheit, Senior Systems Analyst, IBM General Products Division, San Jose, California, *Cooperation in Library Automation: Philosophy and Applications*. PANEL: Hillis L. Griffin, Argonne National Laboratory, Argonne, Illinois, *Machine Aspects of Compatibility*; Mrs. Marjorie R. Hyslop, Associate Director, Documentation Service, American Society for Metals, Metals Park, Ohio, *Sharing Vocabulary Control*; Gertrude E. Schalow, Assistant Librarian, Library Branch, U.S. Bureau of Reclamation, Denver, *Sharing Selective Dissemination of Information*; Abraham I. Lebowitz, Assistant to the Chief, Headquarters Library, U.S. Atomic Energy Commission, Germantown, Maryland, *Sharing Technical Processes and Services*; Arthur E. Jones, Communication Services, Sandia Corporation, Albuquerque, New Mexico, *Sharing Communications Networks*; Chris G. Stevenson, Manager, Technical Information, Pacific Northwest Laboratories, Division of Battelle-Northwest, Richland, Washington, *Sharing in Training of Personnel*. Discussion

Petroleum Section: 2:00-4:30 p.m. *Petroleum Serial Publications*. PRESIDING: George L. Aguirre, Librarian, Esso Standard Eastern, Inc., New York City. PANEL: Gordon H. Barrows, Editor, Petroleum Legislation Ltd., New York City; Russell Palmer, Managing Director, Palmer Publications, New York City; C. B. Squire, Associate Editor, Platt's Oilgram News Service, New York City

Public Utilities Section: 2:00-3:30 p.m. Business Meeting. 3:30-4:30 p.m. Workshop: *Loans and Duplicate Exchanges*. MODERATOR: Morris Hoffman, Librarian, Northern Gas Company, Omaha, Nebraska. PANEL: Mrs. Elizabeth Owens, Librarian, Union Electric Company, St. Louis, Missouri; and Mrs. Clara M. Ray, Librarian, Virginia Electric and Power Company, Richmond

Social Science Division, Social Welfare Section, Planning, Building and Housing Section, and **Insurance Division**: 2:00-4:30 p.m. *Problems of Retirement and Aging*. PRESIDING: C. Eugene Hoyt, Librarian, National Society for the Prevention of Blindness, New York City. SPEAKERS: Mrs. Geneva Mathiasen, Executive Director, National Council on the Aging, Inc., New York City, *The Older American in the Great Society*; Roland Rodrock Randall, Real Estate Counselor, Philadelphia, *Planning and Building for Retirement Housing*; Herbert C. Graebner, Vice President and Dean, American College of Life Underwriters, Bryn Mawr, Pennsylvania, *Financial Aspects of Retirement*; and Marie Ponzio, Assistant Librarian, National Council on the Aging, Inc., New York City, *Publications and Sources of Information Relating to Aging*

Transportation Division: 2:30-4:00 p.m. Business Meeting

Dinner

Advertising and Marketing Division: 6:00-6:45 p.m. Reception for Division's First Conventioneers. Restricted to Division members

Convention-Wide Dutch Treat Cocktail Party: 6:00-6:45 p.m.

ANNUAL BANQUET: 7:00 p.m.

Presiding: William S. Budington, President, Special Libraries Association
Invocation: Reverend G. Hall Todd, Arch Street Presbyterian Church, Philadelphia
Toastmaster: Emerson Greenaway, Director, The Free Library of Philadelphia
Speaker: Professor John William Frey, Franklin and Marshall College, Lancaster, Pennsylvania, *Pennsylvania Dutch for Better or Worse*
Presentation of awards

Reception in Honor of Board of Directors and Award Winners: 9:00-9:30 p.m.
Sponsored by Special Libraries Council of Philadelphia and Vicinity

Division Open Houses: Metals/Materials and Transportation

WEDNESDAY, JUNE 9

Breakfast

Picture Division: 8:00-9:15 a.m. Swap Shop. PRESIDING: Mrs. Helen Faye, Director of Art Editing, Harcourt, Brace & World, Inc., New York City

Social Science Division: 8:00-9:15 a.m. Brainstorming Session. PRESIDING: Philip Rappaport, Senior Librarian, Division of Research and Statistics, New York State Department of Labor, New York City

Morning

ANNUAL MEETING: 9:00 a.m.-12:15 p.m.

Luncheon

Business and Finance Division: 12:30-2:30 p.m. Business Meeting

Geography and Map Division: 12:15-1:45 p.m. Film on cold regions presented by Eunice V. Salisbury, Librarian, U.S. Army Cold Regions Research and Engineering Laboratory, Hanover, New Hampshire. Business Meeting

Metals/Materials Division: Noon-2:00 p.m. Business Meeting

Newspaper Division: 12:30-2:00 p.m. PRESIDING: Rex M. Schaeffer, Librarian, Rochester (N. Y.) *Times-Union & Democrat & Chronicle*. SPEAKER: Dean Wesley Clark, School of Journalism, Syracuse University, New York, *Newspaper Research at Syracuse University School of Journalism*

Publishing, Advertising and Marketing, Museum, and Picture Divisions: 12:30-2:30 p.m. Book and Author Luncheon. PRESIDING: Mrs. Louise Field, Research Associate, The Twentieth Century Fund, New York City. SPEAKER: Arthur Lewis, *Philadelphians I Have Known*

Science-Technology Division: 12:30-2:00 p.m. PRESIDING: Mrs. Helen F. Redman, Head Librarian, Los Alamos Scientific Laboratory, New Mexico. SPEAKER: Curtis G. Benjamin, Chairman, Management Board, McGraw-Hill Book Company, New York City, *Current Problems in Publication of Scientific and Technical Books*

Social Science and Insurance Divisions: 12:30-2:30 p.m. PRESIDING: Philip Rappaport, Senior Librarian, Division of Research and Statistics, New York State Department of Labor, New York City. SPEAKER: Thomas C. Laughlin, Vice-President, Corporate Relations, Continental National American Group of Chicago, *What Makes Your Staff Tick?*

Afternoon

Advertising and Marketing and Publishing Divisions: 2:30-3:30 p.m. PRESIDING: William B. Saunders, Librarian, Marketing Science Institute, Philadelphia. SPEAKERS: Michael H. Halbert, Technical Director and Research Coordinator, Marketing Science Institute, Philadelphia, *Libraries and Automation: Management Point of View*; Mrs. Elin J. Christianson, Librarian, Library Research Department, J. Walter Thompson Company, Chicago, *The Automated You*
Visit to Marketing Science Institute and The Annenberg School of Communications, University of Pennsylvania, 3:30-4:30 p.m.

Biological Sciences Division: 2:00-4:30 p.m. *Cooperation: One-Way Street or Thoroughfare?* MODERATOR: Scott Adams, Deputy Director, National Library of Medicine, Bethesda, Maryland. PANEL: Foster E. Mohrhardt, Director, National Agricultural Library, Washington, D. C., *Cooperation on a National Level*; Herman H. Henkle, Executive Director and Librarian, The John Crerar Library, and member, Board of Directors, The Center for Research Libraries, Chicago, *Cooperation on a Regional Level*; Dr. Francis M. Bolton, Librarian, School of Forestry, Yale University, New Haven, *Cooperation on a Subject Level*

Business and Finance Division: 2:45-4:30 p.m. *Cooperation Between the Business*

Research Bureaus of Universities and Business and Finance Libraries. PRESIDING: Portia E. Kieser, Librarian, Executive Office Library, Libbey-Owens-Ford Glass Company, Toledo, Ohio. SPEAKER: Dr. Louis T. Harms, Director and Editor of the Bureau of Economic and Business Research, School of Business Administration, Temple University, Philadelphia

Documentation Division: 2:00-5:00 p.m. *Workshop and Demonstration on Indexing.* WORKSHOP LEADERS: Mrs. Pauline Atherton, American Institute of Physics, New York City; Everett Brenner, American Petroleum Institute, New York City; Mrs. Claire K. Schultz, Institute for the Advancement of Medical Communications, Bethesda, Maryland. Topics for discussion and demonstration: *Instructions to Indexers—A Critical Review of Old and New: Cutter, Sears, Haykin, Ranganathan, ASTIA, NSA, etc.* (Schultz); *A Review of Various Types of Indexers' Tools—Thesauri, Vocabularies, Subject Heading Lists, By-Products of Mechanized Operations* (Brenner); *Software and Hardware—Problems of Incompatibility* (all leaders); *A Comparison of the Output of Different Indexing Tools and Techniques* (Atherton). SUGGESTED PRE-CONVENTION READING: Bourne, C. P. *Methods of Information Handling.* New York: Wiley, 1963; Atherton, P. *File Organization.* In *Information Handling: First Principles*, chapter 2. Washington, D. C.: Spartan Books, 1963

Geography and Map Division: 2:30-4:30 p.m. Tour of Philadelphia Panorama. PRESIDING: Robert C. White, Map Librarian, University of Illinois, Urbana. SPEAKER: Aloys Strobl, Chief, Cartographic Section, City Planning Commission, Philadelphia, *Maps and the City Plan*

Insurance Division: 3:00-5:00 p.m. Tour of Insurance Society of Philadelphia and The Philadelphia Contributionship for the Insuring of Houses from Loss from Fire. Restricted to Division members

Metals/Materials Division: 2:30-4:30 p.m. *Some International Aspects of Library Cooperation.* PRESIDING: Elsie Ray, Librarian, the Anaconda Company, New York City. KEYNOTER: Dr. Luther H. Evans, Director of International and Legal Collections, Law Library, Columbia University, New York City. SPEAKERS: Karl Baer, Chief Librarian, National Housing Center Library, Washington, D. C., *The International Federation of Library Associations*; Elizabeth M. Walkey, Manager, Library Services, Bell & Howell Research Center, Pasadena, California, *International Cooperation in Translation and SLA's Translations Activities Committee*; K. W. Atkin, Local Information Officer, Development and Information Services, British Iron and Steel Research Association, Sheffield, *International Library Cooperation: A British Viewpoint*; Mrs. Gertrude M. Clark, Librarian, The Stuart Company Division, Atlas Chemical Industries, Inc., Pasadena, California, *Assignment Milan*; Donald A. Redmond, Acting Assistant Director of Libraries, University of Kansas, Lawrence, *Overseas Library Experiences*; and Jo Ann Aufdenkamp, Librarian, Federal Reserve Bank, Chicago, *My Experiences in Liberia*

Military Librarians and Transportation Divisions: 2:30-4:30 p.m. PRESIDING: Charles R. Knapp, Chief, Library Branch, Industrial College of the Armed Forces Library, Fort Leslie J. McNair, Washington, D. C. SPEAKER: Theodore Stein, independent consultant on the application of data processing equipment, New York City, *Librarian, Man, and Machine—How to Cooperate*

Museum and Picture Divisions: 2:30-5:00 p.m. Tour of Independence Hall area, Carpenters Company Library, Pennsylvania Horticultural Society Library, and The Athenaeum of Philadelphia. Refreshments. Restricted to Division members

Newspaper Division: 2:30-4:00 p.m. PRESIDING: Mrs. Marian M. Orgain, Librarian, *The Houston (Tex.) Chronicle.* SPEAKER: Mr. J. T. Simone, Service Bureau Corporation, New York City, *The Total Systems Approach to Newspaper Libraries* Visit to *The Philadelphia Inquirer* Library, 4:15 p.m.

Newspaper and Picture Divisions: 5:00 p.m. Reception for Division members as guests of *The Philadelphia Inquirer.* Restricted to Division members

Science-Technology Division: 2:30-4:30 p.m. Business Meeting

Social Science Division: 3:00-4:30 p.m. Business Meeting

Dinner

Advertising and Marketing Division: 6:30-8:30 p.m. Dutch treat

Biological Sciences Division: 6:30-7:00 p.m. Dutch treat social hour; 7:00 p.m. Dinner. PRESIDING: Joan Titley, Chief Librarian, School of Medicine Library, University of Louisville, Kentucky. SPEAKER: Walton B. McDaniel, II, Ph.D., Curator, Historical Collections, College of Physicians, Philadelphia, *John James Audubon and Icy Philadelphia*

Science-Technology Division

Pharmaceutical Section: 7:00-9:00 p.m. PRESIDING: Elizabeth S. Eaton, Reference Librarian, Health Center, University of Florida, Gainesville. SPEAKER: Dr. Robert S. Raffauf, Group Leader, Science Information Department, Smith, Kline & French Laboratories, Philadelphia, *Pharmaceutical Botany: The Search for Specimens*

Evening

CONVENTION-WIDE NIGHT AT THE RACES: 5:30-Midnight. Sponsored by the Metals/Materials Division for the benefit of the SLA Scholarship and Student Loan Fund. Transportation, admission to reserved Clubhouse area, dinner at Liberty Bell Park, harness racing—\$10.00 (*see also* page 263)

THURSDAY, JUNE 10

Breakfast

Science-Technology Division, Advisory Committee: 8:00-9:30 a.m. Incoming and outgoing Division and Section Officers meeting

Chapter Employment Chairmen: 8:00-9:30 a.m. PRESIDING: Grace Reynolds, Assistant to Executive Director, Special Libraries Association

Morning

Advertising and Marketing and Publishing Divisions: 9:00-11:45 a.m. *Methods Workshops*. Coffee and pastry break. Session I: *Trends in Advertising and Marketing Libraries of the Future*. MODERATOR: May M. Dowell, Director of Special Projects, CBS News, New York City. PANEL: Mrs. Celestine G. Frankenberg, Art Librarian, Young and Rubicam, Inc., New York City, *Graphic Arts*; other panelists to be announced for *Media Files* and *Book Collections*

Business and Finance Division: 8:00 a.m.-5:00 p.m. All-day tour to Eleutherian Mills Library of Business History and the Henry Francis duPont Winterthur Museum. Lunch at duPont Country Club. Restricted to 80 Division members

Geography and Map Division: 9:00 a.m.-5:00 p.m. All-day tour to General Drafting Company, Convent Station, New Jersey. HOST: Paul B. Lee, Assistant to the President

Insurance Division: 9:30-11:30 a.m. *The Compilation of Insurance and Industrial Statistics and Their Uses*. PRESIDING: Agnes Brite, Librarian, New England Mutual Life Insurance Company, Boston. SPEAKERS: Raymond O. Nelson, Manager, Survey Research Division, and Thomas J. Casper, publisher of *The Spectator*, both from Chilton Publishing Company Research Department, Philadelphia

Metals/Materials Division: 9:00 a.m.-4:30 p.m. All-day tour to Bethlehem Steel Company, Homer Research Laboratories and Library, and the Schwab Memorial Library, Bethlehem, Pennsylvania. Restricted to Division members. Lunch as guests of the Bethlehem Steel Company. Brief talks on library cooperation within the company and the community. SPEAKERS: Jean P. Wesner, Librarian, Schwab Memorial Library, Bethlehem Steel Company; Amy C. Preston, Librarian, Bethlehem Public Library, *Local Library Cooperation*; and Robert L. Taylor, Associate Librarian and Director of the Center for the Information Sciences, Lehigh University, Bethlehem, *The Bearing of Lehigh Work with Information Sciences on Interlibrary Cooperation*

Museum and Picture Divisions: 9:00 a.m.-4:30 p.m. All-day tour to Rosenwald Collection, Strawberry Mansion (catered luncheon), and Willet Stained Glass Studio. Restricted to Division members

Newspaper Division: 9:00-11:30 a.m. *Subject Headings for Newspaper Libraries.* MODERATOR: Mrs. Marian M. Orgain, Librarian, *The Houston (Tex.) Chronicle.* PANEL: Florina Conklin, Librarian, *Seattle (Wash.) Times*; Josephine Johnson, Librarian, *Louisville (Ky.) Courier-Journal*; Helen Orcutt, Librarian, *Toledo (Ohio) Blade*; David Rhydwen, Librarian, *Toronto (Can.) Globe and Mail*; and C. G. Vitek, Librarian, *Baltimore (Md.) Sun*

Science-Technology Division

Aerospace Section: 10:30 a.m.-Noon. *Obstacles Facing the Government Contractor's Librarian.* PRESIDING: Dr. Michel O. Friedlander, Director, Engineering Library, Grumman Aircraft Engineering Corp., Bethpage, New York. SPEAKERS: Dr. François Kertesz, Assistant Director, Technical Information Division, Oak Ridge National Laboratories, Tennessee; Joseph C. Shipman, Director, Linda Hall Library, Kansas City, Missouri

Chemistry Section; Biological Sciences and Documentation Divisions, and Pharmaceutical Section: 9:00-Noon. PRESIDING: Mrs. Eleanora Henerey, Technical Librarian, Patent Department, Monsanto Company, St. Louis, Missouri. *Abstracting Services Cooperation.* MODERATOR: Raymond A. Jensen, Executive Secretary, National Federation of Science Abstracting and Indexing Services, Washington, D. C. PANEL: Dale B. Baker, Director, The Chemical Abstracts Service, Columbus, Ohio; Mrs. Phyllis V. Parkins, Director (pro tem), Biological Abstracts, Philadelphia; Peter Warren, Director, Excerpta Medica Foundation, New York City

Public Utilities Section: All-day tour to Peach Bottom Atomic Information Center, York County, Pennsylvania, as guests of Philadelphia Electric Company. Restricted to Section members

Social Science Division: 9:00-11:30 a.m. Computer Session: *Seminar on the Development of the New York Union List.* MODERATOR: Philip Rappaport, Senior Librarian, Division of Research and Statistics, New York State Department of Labor Library, New York City. GUEST SPEAKER: Dr. Henry Soehngen, Head, Computer Center, Polytechnic Institute of Brooklyn, New York. PANEL: Clifford R. Johnson, Librarian, Ford Foundation, New York City; Dorothy Kasman, Librarian, Lybrand, Ross Bros. and Montgomery, New York City; and Carrie Hirtz, Librarian, Research Institute of America, New York City

Committee on Government Information Services: 9:00-10:30 a.m. Open meeting. Representatives from the major government information agencies will outline recent changes and answer questions. PRESIDING: Dr. D. T. Bedsole, Manager, Technical Library, Aerojet-General Corp., Sacramento, California. PANEL: A. G. Abdian, Deputy Administrator, Defense Documentation Center, Alexandria, Virginia; Bernard M. Fry, Director, Clearinghouse for Federal Scientific and Technical Information, Springfield, Virginia; Hubert E. Sauter, Chief, Technical Services Branch, Office of Scientific and Technical Information, National Aeronautics and Space Administration, Washington, D. C.; and John Sherrod, Chief, Information Services and Systems Branch, Division of Technical Information, Atomic Energy Commission, Washington, D. C.

Luncheon

Advertising and Marketing Division: Noon-1:45 p.m. PRESIDING: May M. Dowell, Director of Special Projects, CBS News, New York City. SPEAKER: Richard W. Carpenter, Advertising Director, The Bulletin Company, Philadelphia, *The Newspaper Viewpoint on Advertising and Marketing Libraries of the Future*

Insurance Division: Noon-4:30 p.m. Visit to Huebner Hall and Insurance Library, Bryn Mawr, Pennsylvania, as guests of organizations in Huebner Hall. Restricted to Division members

Newspaper Division: 12:30-2:00 p.m. Jack K. Burness Memorial Award Presentation. PRESIDING: Chester W. Sanger, Chairman, Board of Burness Award, and Librarian, *The Christian Science Monitor*, Boston. SPEAKER: Alfred Friendly, Managing Editor and Executive Vice-President, *Washington (D. C.) Post*

Science-Technology Division

Nuclear Science Section: Noon-5:00 p.m. Luncheon and tour to Princeton-Pennsylvania Accelerator, Princeton, New Jersey

Paper and Textile Section and Forestry Librarians: Noon-1:30 p.m.

Petroleum Section: Noon-6:00 p.m. Tour to New Hope, Pennsylvania, as guests of The Atlantic Refining Company. Restricted to Section members

Social Science Division

Social Welfare Section: Noon-1:30 p.m. PRESIDING: C. Eugene Hoyt, Librarian, National Society for the Prevention of Blindness, New York City. SPEAKERS: Joseph Groesbeck, Deputy Director, Dag Hammarskjold Library, United Nations, *Library Aspects of the Work of the United Nations in Social Welfare and Community Development*; Mrs. Inder Jaipaul, Doctoral student, School of Social Work, University of Pennsylvania, *Community Development in India*; and Gerritje Aalders, Doctoral student, School of Social Work, University of Pennsylvania, *Social Welfare in the Netherlands*

Afternoon

Advertising and Marketing Division: 1:45-3:00 p.m. *Methods Workshops*, Session II: *The Advertising and Marketing Libraries of the Future*. MODERATOR: May M. Dowell, Director of Special Projects, CBS News, New York City. PANEL: Eileen Murphy, Librarian, Legal Department, General Motors Corporation, Detroit, *Equipment*; Honn I. Patton, Jr., Librarian, WBBM-TV, Chicago, *Coordination with Mass Media*. Summary by Moderator

Biological Sciences Division: 1:30-5:30 p.m. Visits to Institute for Scientific Information, etc. Restricted to Division members

Military Librarians Division: 2:00-4:30 p.m. *The Year in Military Librarianship*. MODERATOR: Robert W. Severance, Director, Air University Library, Montgomery, Alabama. Speakers reporting on the present status and the year's progress on current DOD and service programs affecting military librarians, such as STINFO, Federal Library Council, Civil Service Standards, AFLS-MLD Cooperation, etc.

Newspaper Division: 3:00 p.m. Visit to library of the *Evening and Sunday Bulletins*, Philadelphia

Reception as guests of *Bulletin*, 4:30 p.m. Restricted to Division members

Publishing Division: 2:00-5:00 p.m. *Literary Landmarks Bus Tour of Philadelphia*. TOUR DIRECTOR: Howell Heaney, Assistant Head, Rare Book Department, The Free Library of Philadelphia

Science-Technology Division

Paper and Textile Section: 2:00-4:30 p.m. *The Role of the Institutes of the Paper and Textile Industries in the Field of Technical Information*. MODERATOR: George B. Miller, Jr., Supervisor, Technical Information Center, Riegel Paper Corporation, Milford, New Jersey. PANEL: Curtis L. Brown, Acting Librarian and Editor, *Abstract Bulletin of The Institute of Paper Chemistry*, Appleton, Wisconsin; Barnet Kanich, Production Editor, *Textile Research Journal*, Textile Research Institute, Princeton, New Jersey; Robert S. Merkle, Head, Technical Information Service, and Editor, *Textile Technology Digest*, Institute of Textile Technology, Charlottesville, Virginia; Jack Weiner, Editor, Technical Publications, The Institute of Paper Chemistry, Appleton, Wisconsin

Social Science Division

Planning, Building, and Housing Section: 2:00-4:30 p.m. *Planning, Building, and Housing in Philadelphia* bus tour.

Forestry Librarians Second Workshop: 2:00-4:30 p.m. *Library Needs of Forestry Researchers and Educators*. Part I, *Production Utilization and Marketing*. PRESIDING: Margaret Jean Taylor, Librarian, Southeastern Forest Experiment Station, Asheville, North Carolina. SPEAKER: Dr. Wayne K. Murphey, Assistant Professor of Wood Utilization, School of Forestry, College of Agriculture, The Pennsylvania State University, University Park. Discussion

Dinner

Forestry Librarians Second Workshop: 6:00-8:30 p.m. Dutch Treat Cocktail Hour. Part II, *Forest Economics*. **PRESIDING:** Philip B. Perkins, Librarian, Northeastern Forest Experiment Station, Forest Service, U.S. Department of Agriculture, Upper Darby, Pennsylvania. **SPEAKER:** Dr. Ralph W. Marquis, Director, Northeastern Forest Experiment Station, Forest Service, U.S. Department of Agriculture, Upper Darby, Pennsylvania. Discussion

Evening

Science-Technology Division, Aerospace and Engineering Sections and Documentation Division: 6:15-10:00 p.m. Visit to General Electric Space Technology Center, King of Prussia, Pennsylvania, Computer Center, Information Retrieval Center, and Library. **SPEAKERS** (from General Electric Company Missile and Space Division, King of Prussia): L. Cimino, Manager, Information Systems; L. I. Chasen, Manager, Missile and Space Division Library; and Bernard Kodroff, Systems Analyst

FRIDAY, JUNE 11

Morning

Board of Directors Meeting: 9:30 a.m.-5:00 p.m.

Advertising and Marketing Division: 9:00 a.m. Executive Committee. Closed meeting

Biological Sciences Division: 10:00 a.m. Executive Committee. Closed meeting

Science-Technology Division

Chemistry Section: 9:00 a.m. Visit to Atlas Chemical Industries, Inc., Library and E. I. duPont de Nemours and Company Technical Library, Wilmington, Delaware

Forestry Librarians Second Workshop: 9:30-11:30 a.m. Part III, *Developments in Subject Classification in Forestry*. **MODERATOR:** Emily A. Keeley, Head, Library Services, Department of Forestry, Ottawa, Canada. Panel and audience will examine three subject control systems: classified (Oxford), thesaurus (Pulp and Paper Research Institute of Canada), and traditional subject heading lists. Advantages and disadvantages will be brought out, particularly in relation to the type of literature being monitored and the intensity of research needs served by a given system.

Luncheon

Forestry Librarians Second Workshop: Noon. Organization Luncheon. **PRESIDING:** Theodor B. Yerke, Librarian, Pacific Southwest Forest and Range Experiment Station, Forest Service, U.S. Department of Agriculture, Berkeley, California

TOURS AND INFORMATION

GRAY LINE MOTOR TOURS, INC. in Philadelphia is offering a number of historical and cultural tours of Philadelphia and environs. There is free pick-up service at all Philadelphia hotels before the tour departure. For immediate reservations call Philadelphia, WA 2-8555, or write in care of the Benjamin Franklin Hotel, 9th and Chestnut Streets, Philadelphia 19105.

SLA Sustaining Members

These are additions to the Sustaining Members for 1965 listed in *News & Notes* and include all applications processed through March 11, 1965.

AETNA STEEL PRODUCTS CORPORATION

AMERICAN GAS ASSOCIATION

CONSOLIDATED EDISON COMPANY OF NEW YORK

ESSO RESEARCH & ENGINEERING COMPANY

FORD FOUNDATION

INTERNATIONAL BUSINESS MACHINES CORPORATION

NEW YORK LIFE INSURANCE COMPANY

SAN JACINTO MUSEUM OF HISTORY ASSOCIATION

WYETH LABORATORIES, INC.

The 1965 SLA Annual Meeting

AS REQUIRED BY ARTICLE VI, Section 3 of the Bylaws, notice is hereby given that the Annual Meeting of Special Libraries Association will be held Wednesday morning, 9:00 a.m., June 9, 1965, at The Benjamin Franklin Hotel, Philadelphia, Pennsylvania, during the Association's 56th annual Convention. The agenda will include three matters of particular concern to the membership—increasing the limit on the General Reserve Fund and changing the Bylaws to permit revision of the composition of the Advisory Council and to include other recommendations of the Bylaws Committee. Explanations and reasons for these proposed changes are given below:

General Reserve Fund Policy

The Finance Committee, with the Board of Directors' approval, will recommend for membership consideration at the Annual Meeting in Philadelphia, June 9, 1965, that the limit on the General Reserve Fund be raised from \$50,000 to \$100,000.

The General Reserve Fund reached the limit of \$50,000 (placed upon it by membership vote in 1951) in 1960. Since that time, interest income from the Fund has been added to the general operating funds of the Association in accordance with Section 2 of the General Reserve Fund Policy (as amended in 1960), which reads: "There shall be a \$50,000 limit on the General Reserve Fund. Funds received from interest or any other source shall be added to the general funds of the Association."

The Finance Committee believes, as have other Finance Committees before it, that it is necessary, if the Association is to follow a sound financial policy, to maintain the General Reserve Fund at a level commensurate with the growth of the Association membership, the expanding operating budget, and the natural inflation of prices with consequent depreciation of purchasing power of the dollar over the years.

It seems obvious that a \$50,000 General Reserve Fund is less than adequate to assure the continuing operation, in times of need, of an association with a membership of over 6,100 and an operating budget of \$242,000 and that it would, in fact, carry the Association for no more than a few months if its income were substantially reduced. Surely we can and must provide a better margin of safety than this.

In addition, the Finance Committee believes that it is improvident to siphon off interest income from the Fund instead of allowing it to accrue to the Fund. This interest income, at present approximately \$2,000 annually, is not a significant addition to a \$242,000 operating budget, and, in fact, is not essential to maintain our present level of operations within a balanced budget. Left in the General Reserve Fund, it would add to the principal and so contribute to a growing amount of earned interest income.

Your Finance Committee, therefore, will propose the following motion at the Annual Business Meeting:

"That Section 2 of the General Reserve Fund Policy (as amended 1960) be amended to read: There shall be \$100,000 limit on the General Reserve Fund. Interest on the principal shall accrue to the Fund. In addition, the Board of Directors, on recommendation of the Finance Committee, may add funds from other sources to the General Reserve Fund, when the Board of Directors believes this use of such funds to be in the best interests of the Association."

THE FINANCE COMMITTEE
William Beatty, Jean Flegal, Charlotte Madison,
Ralph Phelps, and Janet Bogardus, *Chairman*

Revised Composition of Advisory Council

The proposed change in the Bylaws designed to revise the composition of the Advisory Council comes as a result of considerable concern, investigation, and discussion by the Advisory Council itself, by the Board of Directors, and by interested members.

The Advisory Council, presently composed of Presidents of Chapters, Chairmen of Divisions, and Chairmen of Association Standing and Special Committees, meets twice a year to advise the Board of Directors, but the hoped-for rapport has never materialized. The Board has had difficulty in determining what to ask the Council, and the Council has never been able to define an area of interest and involvement.

The inability of the Association to utilize fully the potential of its Advisory Council has concerned the Board of Directors, as well as the Council, and the President appointed an Ad Hoc Committee to study Council organization in September 1964.

The Ad Hoc Committee found no easy solutions. It did, however, isolate two specific problems which inhibited the effectiveness and authority of the Advisory Council: 1) The Council presently has no continuity. Most of its members serve one-year terms. It is therefore impossible for the Council to organize itself on a continuing basis, since there is no knowledge of who will return the following year. 2) The Council does not function as a representative body. Of its present 87 members, 39 (45 per cent) are committee chairmen, and therefore appointees of the Association President. These individuals, while knowledgeable and devoted to the Association, often feel reluctant about discussing and voting on Association issues, since they realize that their personal vote can cancel the instructed vote of a Chapter President or Division Chairman.

The Ad Hoc Committee findings and recommendations were presented to the Advisory Council at its February 11 meeting in Indianapolis and were discussed by the Council for more than two hours. At the end of this discussion, the Council gave a clear indication of what it wanted its own composition to be. It felt strongly that its own effectiveness could be improved by a change in composition. It voted overwhelmingly its preference for including both present and incoming Presidents of Chapters and Chairmen of Divisions in Council membership, thereby providing for both continuity and experience. It also voted by a four to one margin its belief that committee chairmen should not be members of the Council, and it was obvious that the great majority of committee chairmen present favored their own future exclusion.

The wishes of the Advisory Council were presented by the Ad Hoc Committee as recommendations to the Board of Directors at its February 13 meeting. The Board accepted the recommendations and referred them to the Bylaws Committee for submittal to the Association membership.

Ad Hoc Committee to Study the Composition of the Advisory Council
HERBERT S. WHITE, *Chairman*

Proposed Bylaws

BASIC CHANGE

Article V, Section 2. The Advisory Council shall consist of each Chapter President and President-Elect and Division Chairman and Chairman-Elect. If unable to attend a meeting of the Council, the Chapter President or Division Chairman shall designate an Active member of his respective Chapter or Division to represent the member unable to attend. Members of the Advisory Council shall be Active members of the Association.

Present Bylaws

Article V, Section 2. The Advisory Council shall consist of each Association Committee Chairman, Chapter President and Division Chairman. If unable to attend a meeting of the Council, he shall designate a member of his respective Committee, Chapter or Division to represent him. Members of the Advisory Council shall be Active members of the Association.

Proposed Bylaws

RELATED CHANGES

Article II, Section 3 (*last paragraph*). An Associate member shall have the right to vote, to hold any Chapter or Division office except that of Chapter President and President-Elect or Division Chairman and Chairman-Elect, to affiliate with one Chapter and one Division without further payment, and to receive the official journal free. Upon qualification for Active membership, an Associate member shall become an Active member.

Article II, Section 4. An affiliate member shall be an individual who holds a professional position in an organization other than a special library or information center and who has knowledge and experience that qualify him to cooperate in furthering the objectives of the Association. He shall have the right to affiliate with one Chapter and one Division without further payment, to hold any Chapter or Division office except that of Chapter President and President-Elect or Division Chairman and Chairman-Elect, and to receive the official journal free. An Affiliate member may become an Associate or Active member upon qualification for Associate or Active membership.

Article II, Section 7. Status as an Emeritus member may be requested by an Active member who has held Association membership for 20 years, including any years as an Associate member, and who has reached age 60. An Emeritus member shall have all the rights and privileges of an Active member except the right to hold elective office in the Association or to be a Chapter President or President-Elect or Division Chairman or Chairman-Elect.

Other Changes Recommended by the Association Bylaws Committee

Experience since August 1962, when the Bylaws were adopted, has convinced the Committee that the following amendments to the Bylaws should be considered for adoption.

In Article IX, Section 1, the intent of the Bylaw is simply clarified by a change of sentence structure.

The recommendation for both Article XII, Section 2 and Article XV, Section 3 changes the requirement for voting from "voting members present" to "voting members present and voting."

Present Bylaws

Article II, Section 3 (*last paragraph*). An Associate member shall have the right to vote, to hold any Chapter or Division office except that of Chapter President or Division Chairman, to affiliate with one Chapter and one Division without further payment, and to receive the official journal free. Upon qualification for Active membership, an Associate member shall become an Active member.

Article II, Section 4. An Affiliate member shall be an individual who holds a professional position in an organization other than a special library or information center and who has knowledge and experience that qualify him to cooperate in furthering the objectives of the Association. He shall have the right to affiliate with one Chapter and one Division without further payment, to hold any Chapter or Division office except that of Chapter President or Division Chairman, and to receive the official journal free. An Affiliate member may become an Associate or Active member upon qualification for Associate or Active membership.

Article II, Section 7. Status as an Emeritus member may be requested by an Active member who has held Association membership for 20 years, including any years as an Associate member, and who has reached age 60. An Emeritus member shall have all the rights and privileges of an Active member except the right to hold elective office in the Association or to be a Chapter President or Division Chairman.

For example, based on Article XII, Section 2, if there were 255 voting members present, but only 225 voted, a two-thirds approval by the voting members present would be 166, but a two-thirds approval by voting members present and voting would be 150.

BYLAWS COMMITTEE

Margaret A. Firth, Paul W. Riley, and Margaret H. Fuller, *Chairman*

Proposed Bylaws

Article IX, Section 1. Standing and special committees of the Association and special committees of the Board of Directors shall be established by the Board. These committees shall be responsible to the Board which will delegate such powers and functions to them as the Board finds desirable for the conduct of its business and for carrying out the objectives of the Association.

Article XII, Section 2. Dues for Association membership and fees for additional Chapter and Division affiliation shall be determined by the Board of Directors subject to approval by two-thirds of the voting members present and voting at an annual meeting, provided that written notice shall be given to all voting members at least 60 days in advance of the meeting. Initial dues may be prorated as determined by the Board of Directors.

Article XV, Section 3. Notice containing the text of any proposal shall be sent to each voting member at least 30 days before the annual meeting at which it is to be discussed. If approved by a majority of the voting members present and voting, the proposal shall be submitted to the entire voting membership for mail ballot and final decision. A proposal not approved at the annual meeting may be referred to the Bylaws Committee for review.

The above recommended changes, along with those pertaining to the Advisory Council, will be voted on at the June Annual Meeting and, if approved there, will be submitted for mail ballot ratification to the entire membership during the summer.

Present Bylaws

Article IX, Section 1. Standing and special committees of the Association and special committees of the Board of Directors shall be established by the Board for the purpose of delegating such powers and functions as the Board finds desirable for the conduct of its business and for carrying out the objectives of the Association. These committees shall be responsible to the Board.

Article XII, Section 2. Dues for Association membership and fees for additional Chapter and Division affiliation shall be determined by the Board of Directors subject to approval by two-thirds of the voting members present at an annual meeting, provided that written notice shall be given to all voting members at least 60 days in advance of the meeting. Initial dues may be prorated as determined by the Board of Directors.

Article XV, Section 3. Notice containing the text of any proposal shall be sent to each voting member at least 30 days before the annual meeting at which it is to be discussed. If approved by a majority of the voting members present, the proposal shall be submitted to the entire voting membership for mail ballot and final decision. A proposal not approved at the annual meeting may be referred to the Bylaws Committee for review.

THE MARSHAL CALLS . . . LET'S GO TO THE HARNESS RACES!

The scholarship fund-raising activity, sponsored annually by Metals/Materials Division, will be held on Wednesday night, June 9, at Liberty Bell Park. This will be a gala and luxurious evening with these exciting features: reserved seat in all-weather Turfside Terrace where your dinner seat is your trackside seat, deluxe filet of beef dinner served when you are ready, specially printed tickets, nine races, a race named for us, our name in lights on the "tote board," and other personal touches, all for \$10.00. This is surely the most selfish philanthropy you'll ever support!

Reservations will have to be firm; therefore, MAKE YOUR RESERVATION IN ADVANCE. Send to Elizabeth Frayser, Librarian, Reynolds Metals Co., Fourth & Canal Streets, Richmond 19, Virginia. Make checks payable to Metals/Materials Division.

SLA Hall of Fame 1965

President William S. Budington has announced that two members who have made outstanding contributions to the growth and development of Special Libraries Association at the Association, Chapter, and Division levels over a period of years have been named to the SLA Hall of Fame in 1965:

MARIE S. GOFF has been identified with the Technical Library of E. I. du Pont de Nemours & Company in Wilmington, Delaware, throughout her professional career. She joined the staff as Assistant Librarian a year after graduating from the School of Library Science of Drexel Institute of Technology and a year later was appointed Librarian, a post she held for 40 years until her retirement on February 28. During that period Mrs. Goff developed one of the outstanding business and technical company libraries in the East, organized and administered two branch libraries, and served as a consultant on library problems to du Pont personnel in other locations. A firm believer that special librarians should promote and contribute to their profession, she frequently appeared on radio, television, and in person to discuss librarianship, presented papers at professional meetings, wrote for library periodicals, lectured at Drexel's Library School for ten years (a service that earned for her the 1956 Alumni Citation "In recognition of outstanding achievements and services in the field of library science."), and since 1925 participated in numerous activities of Special Libraries Association. She chaired or was a member of the International Relations, Membership, Nominating, Scholarship and Student Loan Fund, and Professional Standards Committees as well as on the editorial board of *Special Libraries*; served as Vice-Chairman, Chairman, and historian of the Chemistry Section of the Science-Technology Division; and contributed to the Business and Finance Division's volume, *Sources of Commodity Prices*, which was published by the Association. Mrs. Goff's activities in the local Chapter, the Special Libraries Council of Philadelphia and Vicinity, were equally numerous: Vice-President, 1949-50, President, 1950-51, and winner of the 1962 Special Achievement Award. She also assisted in the compilation of the Philadelphia Science-Technology Group's two Association publications, *Numerical Index to the Bibliography of Scientific and Industrial Reports, Volumes 1-10, 1946-48* and *Correlation Index: Document Series and PB Reports, Volumes 1-17, January 1946- June 1952*.



RUTH H. HOOKER is a native of Nebraska who has made a name for herself as a successful special librarian and government career woman in Washington, D. C. Upon graduation from George Washington University she was hired by the U. S. Naval Research Laboratory as a junior physicist, and her work in searching technical literature led her to acquire further education in library science at her alma mater. In 1930, the year she joined Special Libraries Association, Mrs. Hooker was named Librarian of the Naval Research Laboratory. She held this position until her retirement this February 12, except for a three year period, 1951-54, when, at the request of the Secretary of the Navy, she served as Coordinator of all Navy libraries in the Washington, D. C. area. When she joined the NRL library the staff consisted of only two people, but under her leadership it became a comprehensive scientific collection requiring a staff of 40 by 1965. Her contributions to improved technical library service in the Navy were recognized when she was presented a Meritorious Civilian Service Award in August 1964. Mrs. Hooker has served Special Libraries Association in many capacities

too. She was a charter member of the Washington, D. C. Chapter, its first Treasurer, 1940-42, and its President, 1945-48. In 1947 she was elected Second Vice-President of the Association itself, First Vice-President, 1948-49, and President 1949-50. For many years she represented SLA on the Joint Committee on the Union List of Serials, the CNLA Committee for the Protection of Cultural and Scientific Resources, and the Library of Congress Committee for Public Law 480. She is currently a member of the Professional Standards Subcommittee on a Code of Ethics. Mrs. Hooker has written and presented technical papers and bibliographies and has been active in other professional societies, including American Library Association, American Documentation Institute, and District of Columbia Library Association. She was instrumental in organizing the Council of Librarians of the East Coast Navy Laboratories and served as its first Chairman, and she has served on numerous government committees concerned with librarians and library service.

Have You Heard . . .

State Library Consultants Study

The University of Illinois Library Research Center has undertaken a nation-wide study of state library consultants, with the aid of a grant of \$7,686 and sponsored by the Illinois, Indiana, Wisconsin, and Missouri state libraries. 242 questionnaires have been sent to consultants in all 50 states, and the results of the study will be published in September 1965 as number five in the Illinois State Library Research series. These results will be used to aid in training, recruiting, and retaining qualified persons.

Expanded Government Patent Announcements

The Clearinghouse for Federal Scientific and Technical Information is expanding its patent announcement service by using two categories: government-owned U.S. patents and privately owned patents in high-interest subject areas. Government-owned patents were previously announced in a semi-annual report called the *Patent Abstract Series*, which has been discontinued, and are now in the semi-monthly *U.S. Government Research and Development Reports* along with privately owned patents. With the March 20th issue, private patents granted in the area of lubricants were listed. Copies of *USGRDR* are available from the Government Printing Office at \$15 a year. Copies of patents announced in *USGRDR* are 25 cents each from the Commissioner of Patents.

Toward a Better Employment Service

The use of the United States Employment Service and its affiliated state agencies by libraries and librarians is being urged by the Council of National Library Associations until it has effected a long-range solution to the placement problem. In the interim, the Employment Service is ready to provide assistance to the individual professional job-seeker through its Professional Placement Centers located in major cities. Also helping to fill the gap are the placement services available at the annual conventions of the American Library Association and Special Libraries Association as well as SLA's Placement Service at Association Headquarters and that available from Chapter Employment Chairmen.

Name Change for Midwest Inter-Library Center

The Center for Research Libraries is the new name of The Midwest Inter-Library Center in Chicago. The name change reflects the enlarged scope of the Center, which now extends to all research libraries, not only those in the Midwest, and also indicates an expanding program of cooperative acquisitions and library assistance in making increased library research resources available to libraries in the United States, Canada, and potentially, Mexico. These changes are the result of a recent survey on the services and programs of the Center. Details may be obtained by writing Gordon Williams, Director, 5721 Cottage Grove Avenue, Chicago 60637.

Members in the News

DORCAS H. CHEAVENS has recently been appointed Librarian of the Technical Library at E. I. duPont de Nemours & Company, Wilmington, Delaware. PHYLLIS V. GENTIEU has been named Assistant Librarian.

CARRIE W. EAGON, former Research Librarian, Jersey Production Research Company, Tulsa, Oklahoma, is now Chief Librarian at Esso Production Research Company, Houston, Texas.

In Memoriam

ESTHER S. KALIS, Manager, Development Library, General Electric Company, Schenectady, since 1961 died March 11. From 1955-61 she served GE as Librarian of the Manager Development Library in Ossining, New York. In 1958-59 Miss Kalis was Chairman of the SLA Advertising Division, and from 1962-64 she was a member of the International Management Congress Committee and contributed to *The Literature of Executive Management: SLA Bibliography No. 5*. In 1963-64 she served as Chairman of the McKinsey Foundation Book Award Program Committee.

Unified Chemical Information Program

In cooperation with other federal agencies, the National Science Foundation has awarded \$463,000 to the American Chemical Society/Chemical Abstracts Service for research ultimately aimed at mechanizing the handling of chemical information. The grant is part of a broad intra-governmental cooperative effort to develop a unified chemical information program providing high speed, flexible response to the information needs of science and industry. Future arrangements with ACS will be developed as a single government contract handled by NSF, and funds will be supplied by the Department of Defense, National Institutes of Health, and NSF. An interagency Coordinating Group will direct the administrative and technical aspects of the multi-agency support program. Academic and industrial interests will be included. The present NSF grant is the initial support effort under the multi-agency arrangement.

There are also plans for a coordinated two-year government support program, and funds will be used for research in other areas, such as storage and retrieval of graphic information, linguistic, and classification problems. After an evaluation at the end of the two-year period, further steps to be taken will be determined by interested federal agencies.

Coming Events

The Center for Technology and Administration at The American University, 2000 G Street, N.W., Washington, D. C., is sponsoring an INSTITUTE OF MANAGEMENT THROUGH DATA CONTROL AND COMMUNICATIONS on June 7-10. The theme is "Advances in Data Communications," and the meeting place is the Executive House in Washington, D. C. Total registration fee is \$175. The Center is also offering an INSTITUTE ON MODERN ARCHIVES ADMINISTRATION on June 7-18 at the National Archives Building, Washington, D. C. The tuition fee is \$150.

AN INSTITUTE ON RESEARCH ADMINISTRATION, April 26-29, will be held at the Executive House, Washington, D. C. The theme is the "Changing Policies Affecting Operational Problems in Government-sponsored Basic and Applied Research and Development." Complete registration is \$175. For further information about these meetings, write Paul W. Howerton, Director of the Center.

Documentation Division Display

During the forthcoming SLA Convention, the Documentation Division plans to display exhibits illustrating the use made of documentation technology in library environments. If your library or information center has recently instituted mechanized or semi-mechanized procedures you would like to have graphically displayed at the Convention, please communicate with Irving M. Klempner, Chairman-Elect, Documentation Division, United Nuclear Corporation, 5 New Street, White Plains, New York 10601.

Off the Press . . .

Subject Bibliographies Available

The Document and Supply Centre of Robert Maxwell and Company, Ltd., London, and the Documentation and Procurement Center of Maxwell Scientific International, Inc., 44-01 21st Street, Long Island City 1, New York, have compiled and edited 36 international subject bibliographies that will be revised annually and cover the fields of electronics, graphic arts, cartography, the cinema, and other scientific and arts subjects. Each bibliography is free upon request, and the publications listed in it may be obtained from the above address in the United States. Only a selected list of publications, not including periodical literature, theses, or patents are covered during a certain period. Prices are stated when available, and the format is alphabetical by author.

More on "British Museum Subject Index"

H. Pordes, 529b Finchley Road, London, N. W. 3, has announced that a further three volumes of the *British Museum Subject Index* (noted in Recent References, *Special Libraries*, December 1964) have gone out of print and will accordingly be included in the reprint. These are the first three volumes covering the years 1881-1900, and the price will be \$30 each (other volumes, \$36 each). Thus the complete reprint will consist of ten volumes covering the years 1881-1925 and 1936-1940.

Plenum Press Establishes Data Division

Plenum Press, the New York publisher of scientific books and translated journals, has inaugurated a program of providing in published book form scientific and engineering data previously available only at computer data processing centers. The first work to be issued is *Electronic Properties of Materials: A Guide to the Literature*, a hefty 1,700 page two-volume set edited by H. Thayne Johnson and selling for \$150. It is a product of the Electronic Properties Information Center (EPIC), established by Hughes Aircraft Company as an Air-Force-funded project, and represents the work of a team of six to eight scientists who have scanned the international literature on electronic properties and selected 13,500 publications as within the scope of the project. A modified coordinate indexing system was adopted, and an IBM 1401 was programmed for the complex input. Volume one contains the master print-out of the alphabetically arranged descriptor file covering 59 properties of 10,000 materials. Under each heading are accession numbers referring to source articles, and by comparing numbers appearing under two or more descriptors, one can locate articles containing information on these subjects.

Volume two, prepared and printed out on a Flexowriter controlled by the computer, contains full bibliographic citations for the accession numbers. Supplements will be issued every two years, and the Data Division plans to publish similar literature searching tools emanating from other specialized information centers.

SLA Authors

ANDERSON, Frank J. Recruitment Release. *Library Journal*, vol. 90, no. 4, February 15, 1965, p. 829.

BLACK, Donald V. Automatic Classification and Indexing, for Libraries? *Library Resources and Technical Services*, vol. 9, no. 1, winter 1965, p. 35-52.

BRY, Ilse, co-author. Bibliographical Challenges in the Age of the Computer. *Library Journal*, vol. 90, no. 4, February 15, 1965, p. 813-18.

CUSHMAN, Jerome. A Reader Looks at the Notable Books. *ALA Bulletin*, vol. 59, no. 2, February 1965, p. 105-10.

PRENTISS, S. Gilbert. The Public Library System Program in New York State. *Library Trends*, vol. 13, no. 3, January 1965, p. 287-95.

SHAW, Ralph R. Integrated Bibliography. *Library Journal*, vol. 90, no. 4, February 15, 1965, p. 819-22.

———. The Form and the Substance. *Library Journal*, vol. 90, no. 3, February 1, 1965, p. 567-71.

SWANSON, Don R. The Evidence Underlying the Cranfield Results. *The Library Quarterly*, vol. 35, no. 1, January 1965, p. 1-20.

TATE, Elizabeth L. Response to the Reflections. *The Library Quarterly*, vol. 35, no. 1, January 1965, p. 27-30.

TITLEY, Joan. Dr. Charles Wilkins Short and the Medical Journals: 1820-1831. *Stecher-Hafner Book News*, vol. 19, no. 3, November 1964, p. 29-31.

WARHEIT, I. A. Dissemination of Information. *Library Resources and Technical Services*, vol. 9, no. 1, Winter 1965, p. 7380.

New Serials

ACTA MECHANICA is an international quarterly devoted to the exchange of ideas in the field of theoretical and applied mechanics with special attention to recently developed and boundary areas of mechanics. Contents will be published in German and English. The annual subscription price is \$32 plus postage from Springer-Verlag, 175 Fifth Avenue, New York 10010.

DREXEL LIBRARY QUARTERLY, published by the Graduate School of Library Science at Drexel In-

stitute of Technology, replaces *The Drexel Library School Series* and will treat a single subject from various angles with papers of greater length. The first issue contains the proceedings of the Public Relations Workshop for Practicing Librarians. Annual subscriptions are \$10 and may be ordered from Carole Butcher at Drexel.

METROLOGIA, an international quarterly of scientific metrology, is published by Springer-Verlag under the auspices of the International Committee of Weights and Measures. The content will cover original research, review articles, letters to the editor, and activities of the International Conference of Weights and Measures, the ICWM, and the International Bureau of Weights and Measures at Sevres. It will be published in English, French, German, and Spanish. Annual subscription cost in the United States is \$8.50, available from the publisher at 175 Fifth Avenue, New York 10010.

SCIENCE JOURNAL, published monthly by Associated Iliffe Press Limited, London, provides concise and authoritative reports of all new developments in the field of science and technology throughout the world. Also included are book listings, letters to the editor, and reports of meetings. Subscriptions in the United States and Canada are \$12 for one year and \$24 for 36 months and are available from British Publications, Inc., 30 East 60th Street, New York 10022.

RECENT REFERENCES

Prepared by JOHN R. SHEPLEY

Librarianship

COX, Julius Grady. *Optimum Storage of Library Material*. Lafayette, Ind.: Purdue University Libraries, 1964. xv, 222 p. post binding. Apply.

Doctor's thesis. Offers a structure of the overall storage problem with emphasis on one aspect, the saving of space through the use of compact storage.

Med Boken som Bakgrunn: Festskrift til Harald L. Tveteras. Oslo: Johan Grundt Tanum, 1964. xii, 263 p. Apply.

With the Book as Background. A celebration volume for Harald L. Tveteras, first librarian of Unesco in 1947. Essays on a variety of subjects by many hands; those in English include: "Samuel Johnson and Oxford," by Louis B. Frewer; "The Birth of Unesco's Library Programmes," by Edward Carter; "A Note on Cataloguing at the International Level," by Herbert Coblans; "Scientific Information and the Economy," by Alexander King; and "The National Union Catalog of the Library of Congress—Its Past and Its Prospects," by L. Quincy Mumford. Bibliography of Tveteras' writings.

Bibliographical Tools

ALLSWANG, John M. and BOVA, Patrick, eds. *NORC Social Research, 1941-1964: An Inventory of Studies and Publications in Social Research*.

Chicago: National Opinion Research Center, University of Chicago, 1964. vi, 80 p. pap. \$2.50. (Available from NORC Library, 5720 South Woodlawn Ave., Chicago 37, Ill.)

Describes the social surveys and other projects undertaken by NORC from its founding in 1941 through the middle of 1964, and lists NORC and other publications that have resulted from these studies. Indexes of studies, Roper Center studies, sponsors, authors and study directors, and subjects. Price includes three half-yearly supplements through the end of 1965.

BLAU, E. J. *An Annotated Bibliography on Plasmas in Cusped Magnetic Fields and Similar Geometries* (TG 230-B4). Silver Spring, Md.: Applied Physics Laboratory, Johns Hopkins University, 1964. iv, 46 p. pap. spiral binding. Apply.

176 titles, both report and journal literature. up to April 1964. Author index.

FOX, Gertrude W., comp. *Design of Clean Rooms: A Classified List of Selected References—1955-1964* (Public Health Service Publication No. 1219). Bethesda, Md.: U. S. Department of Health, Education, and Welfare, 1964. vi, 15 p. pap. 15¢. (Available from Government Printing Office)

139 entries covering the design, construction, and maintenance of clean rooms, surgical suites, laboratories, germfree animal quarters, etc. Limited to papers in English. Author index.

FEDERAL AVIATION AGENCY AERONAUTICAL CENTER, Administrative Services Division, Library Branch. "*Whatdunnit*"—*Aircraft Accidents, their Investigation and Prevention Practices: Selected References* (Bibliographic List No. 1). Oklahoma City, Okla.: P. O. Box 1082, 1964. 76 p. pap. Apply.

688 entries, some annotated, divided into periodical articles, books, reports, and miscellany. No index.

———. *Fuel Cells: Selected References* (Bibliographic List No. 2). Oklahoma City, Okla.: P. O. Box 1082, 1964. 101 p. pap. Apply.

497 entries, usually annotated, covering research in fuel cells from 1953 through March 1964. Arrangement by subject. Personal name index.

HOBBS, Cecil, comp. *Southeast Asia: An Annotated Bibliography of Selected Reference Sources in Western Languages*, rev. ed. Washington, D. C.: Library of Congress, 1964. vi, 180 p. pap. \$1. (L. C. 63-60089) (Available from Government Printing Office)

Updates and expands a 1952 publication. 535 books, most of them from the years 1952 to 1963, on Burma, Thailand, Cambodia, Laos, Vietnam, Malaysia, Indonesia, and the Philippines, arranged under the subject headings of General Background; History, Politics, and Government; Economics; Social Conditions; and Cultural Life. Annotations appraise not only the text but also

the bibliographies, maps, illustrations, statistical tables, and documents contained in the book. Index.

HOUSING AND HOME FINANCE AGENCY LIBRARY. *Bibliography on Housing, Building and Planning for Use of Overseas Missions of the United States Agency for International Development*. Washington, D. C.: 1964. ii, 52 p. pap. Apply.

Revision of a 1963 publication. Lists approximately 500 recent books and periodicals available in the United States. Arrangement is by subject, Aided Self-help Housing to Zoning. Directory of publishers; author index.

MAICHEL, Karol. *Guide to Russian Reference Books*, Vol. II: *History, Auxiliary Historical Sciences, Ethnography, and Geography* (Hoover Institution Bibliographical Series XVIII). Stanford, Calif.: Hoover Institution on War, Revolution, and Peace, 1964. 297 p. \$12. (L. C. 62-14067)

Lists and annotates 1,560 reference works such as bibliographies, indexes, encyclopedias, chronologies, biographies, terminological dictionaries, atlases, gazetteers, and handbooks. Index. Second volume of a projected six-volume series, and can stand alone; the first volume, however, *General Bibliographies and Reference Books*, is available for \$5.

NATIONAL MANAGEMENT ASSOCIATION. *Science and Engineering Management: A Selected and Annotated Bibliography of Research, Development and Engineering Management Literature*. Dayton, Ohio: 333 West First St., 1964. vi, 26 p. pap. Gratis.

118 books and articles grouped under the headings "Management (General)," "Planning and Controlling," "Organization," and "Personnel Management." Annotation, in the form of a summary discussion, precedes the listing of the entries, which is alphabetical by title. No index.

PORT OF NEW YORK AUTHORITY LIBRARY. *A Selected Bibliography of the Port of New York Authority, 1921-1964*. New York: 111 Eighth Ave., 1965. 118 p. pap. Apply.

1,333 items by or about the Port of New York Authority. Includes articles, reports, hearings, speeches, laws and statutes, manuals, and visual aids. Most of the material listed is available only on interlibrary loan from the library at the Port of New York Authority. Author and subject indexes. Supplements planned.

SIGNEUR, Austin V. *Guide to Gas Chromatography Literature*. New York: Plenum Press, 1964. 351 p. \$12.50. (L. C. 64-20743)

7,577 references to the published literature and to papers presented at scientific meetings in the field of gas chromatography through late 1963. When available, references are given to *Chemical Abstracts*. Complete pagination supplied as an aid in procuring microfilm or photostatic copies. Author and subject indexes.

Indexes and Catalogs

CLEVELAND PUBLIC LIBRARY. *Catalog of Folklore and Folk Songs*, 2 vols. Boston: G. K. Hall & Co., 1965. Prepublication price: U. S., \$85; outside U. S., \$93.50. After July 31, 1965: U. S., \$105; outside U. S., \$115.50.

Folktales, riddles, proverbs, fables, chapbooks, romances, folk songs and ballads; works on superstition, magic, witchcraft; studies of folk habits, beliefs, and customs. 24,200 cards, arranged by subject and filed alphabetically under the subject headings.

Cumulated Dramatic Index, 1909-1949, 2 vols. Boston: G. K. Hall & Co., 1965. \$490; outside U. S., \$539.

A cumulation of the 41 volumes of the annual *Dramatic Index* originally published by the F. W. Faxon Co. More than 150 American and British periodicals are indexed; 300,000 entries interfiled in a single alphabet. Appendix contains an additional 50,000 entries covering an "Author List of Books about the Drama," "Title List of Published Play Texts," and "Author List of Published Play Texts."

UNIVERSITY OF LONDON. *Library Catalogue of the School of Oriental and African Studies*, 28 vols. Boston: G. K. Hall & Co., 1964. U. S. and British Isles, \$1600; elsewhere, \$1760.

554,000 entries, dealing with the whole of Asia, Oceania, and Africa. Subjects covered are language, literature, philosophy, religion, geography, history, law, anthropology, sociology, economics, politics, art, and archaeology. Catalogue has been divided into 14 sections (Author Catalogue, 8 vols.; Title Index, 5 vols.; General Subject Catalogue, 1 vol.; African Subject Catalogue, 1 vol.; etc.), these sections being available separately at varying prices.

CLASSIFIED ADVERTISING

Positions open and wanted—50 cents per line; minimum charge \$1.50. Other classifieds—75 cents a line; \$2.25 minimum. Copy must be received by tenth of month preceding month of publication.

POSITIONS OPEN

ADMINISTRATIVE LIBRARIAN—An opportunity to develop and coordinate a Library Department by assuming administrative and supervisory responsibility for three separate libraries; School of Nursing; Gilbert Horrax Memorial Library (medical); and the Patients' and Employees' Library with the major portion of time given to the School of Nursing Library as a part-time faculty member. Master's degree in Library Science required plus adequate practical experience. Salary \$7,000 to \$8,000. Position available July 1, 1965. For further information and application, write Nancy Howard, Assistant Personnel Director, New England Deaconess Hospital, 185 Pilgrim Road, Boston, Massachusetts 02215.

ART LIBRARIAN—Assistant. Assist with book selection, cataloging, and general administration of fast growing art museum library serving museum staff, college students, and the public. Staff of two professionals, two non-professionals and a part-time page. Required: MLS degree from accredited school, history of art background and a reading knowledge of one or more languages. Opportunity to participate in all phases of library work in an active museum and art school. Library recently moved to new quarters, with room to grow. 38½ hour week. One month vacation. Generous sick leave. Social Security. Blue Cross and Blue Shield available. Generous retirement plan. Salary open. Apply Librarian, Toledo Museum of Art, Box 1013, Toledo, Ohio 43601.

DOCUMENTATION SPECIALIST—To organize and supervise documentation and information services for Toxicology Center, University of California, Davis, including development of literature resources, evaluation, abstracting and coding scientific information, and preparation of literature surveys. Advanced degree in chemistry or equivalent experience required; some training in library science desirable. Experience in documentation valuable, but training will be offered. Interested parties send curriculum vitae to Prof. G. F. Stewart, Toxicology Center, University of California, Davis, California.

JOHNS HOPKINS UNIVERSITY—New air-conditioned library. Positions open July 1. Experience required in technical services, acquisitions, serials cataloging. Group life and health insurance, social security, pension plan. Apply Personnel Office, The Johns Hopkins University Library, Baltimore, Maryland 21218.

LIBRARIAN—Part-time or full-time, New York City, non-profit organization. Some background in psychology, psychic research, and related areas helpful but not essential. Salary open. Write Box C 9.

LIBRARIAN—To assist in industrial library in eastern Pennsylvania. L.S. degree required; technical, financial, or economic training helpful. Good salary. Excellent benefits. Beautiful air-conditioned library. An equal opportunity employer. Write Box C 12.

LIBRARIAN REFERENCE—For organization serving aerospace industry on nationwide basis. Busy, service-oriented operation. Must handle own correspondence, telephone inquiries. Technical experience essential. Send complete resume, including salary information to Box C 5.

LIBRARY DIRECTOR—Plan and administer library services to a rapidly expanding technical college community. New building in early planning stages, substantial funds available for major expansion of collection. College located in the heart of Vermont's vacationland, convenient to Dartmouth and the University of Vermont. ALA accredited M.S. required. Some science background or prior administrative experience valuable, but

not essential. Initial salary \$7,000, faculty status, generous fringe benefits. For more details, send resume to Richard Savoy, Chairman, Faculty Library Committee, Vermont Technical College, Randolph Center, Vermont.

POSITIONS WANTED

CATALOGER—Man, M.S.L.S. desires relocation in New York City Metropolitan area. Five years experience in cataloging and two years in circulation. French and German. Published bibliography. Present salary over \$7,000. Write Box C 11.

SENIOR LIBRARIAN—Languages, sciences, MLS background. Supervisory experience in university and research libraries. University teaching and graduate study beyond MA. Prefer industrial research or university library. For resume write Box C 10.

FOR SALE

TRANSLATIONS—Japanese Patents, 1953 to latest week; extensive partial translations available for \$15-\$30; most subjects return air mail; 150,000 specifications on file. Cite publication number and year. Rotha Fullford Leopold & Associates Pty., Ltd., P.O. Box 13, Black Rock, Victoria, Australia. Cables ROFULE Melbourne.

WANTED TO BUY

PERIODICALS, duplicates, surplus for cash or exchange. Write for free Library Buying List. Canner's SL, Boston 20, Massachusetts.

MISCELLANEOUS

SEND YOUR BOOK WANTS to our free book-find service. Join the happy band of special libraries who have discovered our astonishingly successful results, courteous promptness, and indefatigability. No book wants? Send for free ball-point pen, anyway. Martin Gross, Booksellers, 1 Beekman Street, New York, N. Y. 10038.

**LIBRARY CONSULTANT—
DATA PROCESSING
SYSTEMS
AND
INFORMATION RETRIEVAL
THEORY**

PATRICK J. GLEASON

142-20 84th Drive, Jamaica, New York 11435

ASSISTANT LIBRARIAN

Engineering Library—To oversee technology support function, including order, cataloging, specifications, and reference work. Monitor incoming material (documents, periodicals, reports, etc.) for routing to potentially interested groups or individuals. Perform more complicated types of literature searches requiring specialized training in use of periodical and serial indexes, reference works, and other bibliographic tools. Responsible for library operations in absence of library supervisor. Salary open.

Send resume to:

G. A. Caywood
The Boeing Company
Wichita, Kansas

An equal opportunity employer. Proof of U. S. citizenship required.



PRINTS CATALOG CARDS



EASY
TO USE
FAST

AT
LOW
COST

Hundreds of Libraries—big and small—now print 3 x 5 professional catalog cards and postcards (any quantities) with new precision geared stencil printer especially designed for Library requirements. Buy direct on Five Year Guarantee. FREE—Write TODAY for description, pictures, and low direct price. **CARDMASTER, 1920 Sunnyside, Dept. 44, Chicago 40**

SWETS & ZEITLINGER

Keizersgracht 471 & 487
Amsterdam-C. Holland

Publishers and Library Agents
Current Subscriptions

Periodicals, Sets, Backfiles, and Separate
Volumes.

American Representative

WALTER D. LANTZ

555 WOODSIDE AVE., BERWYN, PA.

Suburban Philadelphia Phone: Niagara 4-4944

DOCUMENTALIST

Candidates should possess an M.S. degree in Library Science with a minimum of five years experience in the technical library field. Will assume complete responsibility for the external and internal report collection of the Research Division and develop machine computer systems for the preparation of index and control records with eventual direct machine retrieval.

This position is in Rochester, New York. Please forward a resume, including salary history, in confidence to: Mr. Donald A. Zrebiec, Department SL-4, Xerox Corporation, P.O. Box 1540, Rochester, New York 14603.

XEROX

An Equal Opportunity Employer

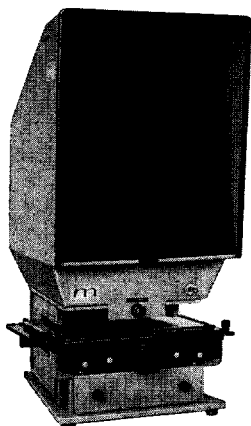

THE WORST HAS HAPPENED...

(The light bulb burned out.)

We're embarrassed to admit it, but the Microcard® Mark IV Reader is only 99% maintenance-free. Everything is fine, day after day . . . the image is brilliantly sharp and clear . . . and then, *phttt* . . . the bulb burns out. But you can replace the burned-out bulb in just 10 seconds, (no tools to fuss with). Then the Mark IV is all set for many more hours of trouble-free operation. In fact, if we could find a light bulb that never burned out, we'd have a 100% maintenance-free reader. *No other part in the Mark IV ever wears out!*

The Mark IV also offers unsurpassed image clarity and simplicity of operation. If you're interested in a microfiche reader for your library, please write us. We'll send you complete information . . . no obligation, of course. In the meantime, we'll keep looking for a *phttt*-free light bulb.



DEPT.

**MICROCARD®
CORPORATION**

WEST SALEM, WISCONSIN

Expert Service on

MAGAZINE SUBSCRIPTIONS

for

SPECIAL LIBRARIES

•

Faxon's Librarians Guide

Available on Request

•

For the very best subscription service
—ask about our Till Forbidden Auto-
matic Renewal plan.

•

F. W. FAXON CO., INC.

515-525 Hyde Park Avenue

Boston, Mass. 02131

Continuous Service To Libraries Since 1886

Magafiles



**LOW COST PERIODICAL
AND PAMPHLET FILES**

ALL SIZES SAME PRICE

\$3.18 per doz. any assortment desired.
12 doz. or more, **\$2.88 per doz.**

FREE SAMPLE MAGAFILE sent upon request. You will receive it by return mail along with handy size-chart and additional details. No obligation or salesman follow-up.

Magafiles sell themselves

THE MAGAFILE CO.
P. O. BOX 3121 • ST. LOUIS 30, MO.

SPECIAL LIBRARIES

**“Bro-Dart’s
Directory of
Library Supplies
has everything,”**

said the
Book Truck (Cat. No. 54 909),
movingly.

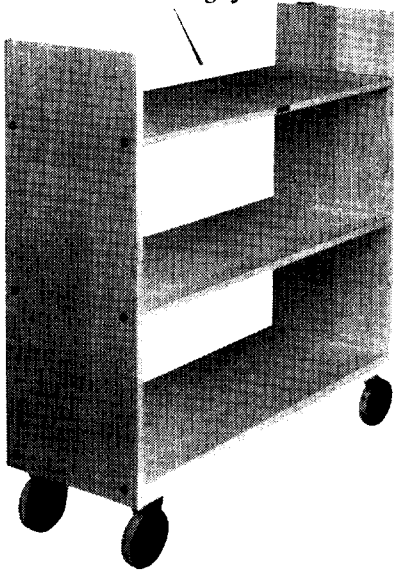

**“You might say that
they have everything
a library
could possibly need,”**

said the
Plasti-Kleer®
Magazine Binder (Cat. No. 51 540),
clearly.

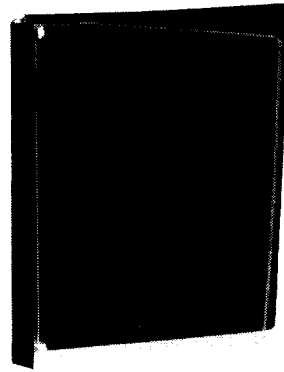

**“For anything
you’ll ever need
for the library,
check the Bro-Dart
Directory of
Quality Supplies
and Equipment,”**

the left-handed shears
(Cat. No. 42 142)
added sharply!

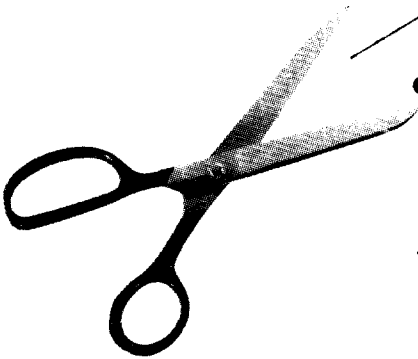

Only by **Bro-Dart** Industries ■ Dept. 1552B, 56 Earl St., Newark, N. J. 07114
1888 S. Sepulveda Blvd., Los Angeles, Calif. 90025
IN CANADA: Bro-Dart Industries (Canada) Ltd., 520 King St., West ■ Toronto, Ontario

BUYERS • SELLERS • COLLECTORS • APPRAISERS

Evaluate
rare and OP books
accurately with

BOOKMAN'S PRICE INDEX

edited by Daniel F. McGrath

Curator of Rare Books, Duke University

Rare book and periodical values have long been a source of frustration, confusion, and doubt to both buyers and sellers. Here at last, in one volume, is a 2,000 double-column-page master index to the essential information contained in the 1963 catalogs of the leading American and foreign rare book dealers—a general buying and pricing guide to the value of 60,000 rare and out-of-print books, monographs, reference works, and runs of periodicals. It is a comprehensive trade standard published to let you accurately judge the going market value, the probable cost to you of a particular publication on any subject.

Of the first annual edition's approximately 60,000 entries, Section I includes nearly 32,000 rare books listed by author, and Section II lists approximately 28,000 sets and runs of general and professional periodicals listed by title.

Each section is compiled as a separate index, and the listing for each title supplies dealer's catalog information concerning the book, including price and condition, the dealer concerned, and the specific catalog in which the book is offered and described. (Thus, BPI serves as an index to your catalog collection, also.)

Add versatile BPI to your reference shelf now. Save time in finding needed material. Protect against financially costly mistakes.

Annual publication 8½ x 11 Cloth Bound \$32.50

Order on approval . . . Use without obligation for 30 days

GALE RESEARCH COMPANY

2200 Book Tower • Detroit 26, Michigan