

1-1-2013

The Role of Canids in Ritual and Domestic Contexts: New Ancient DNA Insights from Complex Hunter-Gatherer Sites in Prehistoric Central California

Alan M. Leventhal
San Jose State University, alan.leventhal@sjsu.edu

Brian F. Byrd

Anna Cornellas

Jelmer W. Eerkens

Jeffrey Rosenthal

See next page for additional authors

Follow this and additional works at: https://scholarworks.sjsu.edu/anth_pub



Part of the [Anthropology Commons](#), and the [Urban Studies and Planning Commons](#)

Recommended Citation

Alan M. Leventhal, Brian F. Byrd, Anna Cornellas, Jelmer W. Eerkens, Jeffrey Rosenthal, Tim R. Carpenter, and Jennifer A. Leonard. "The Role of Canids in Ritual and Domestic Contexts: New Ancient DNA Insights from Complex Hunter-Gatherer Sites in Prehistoric Central California" *Journal of Archaeological Science* (2013): 2176-2189. <https://doi.org/10.1016/j.jas.2012.12.020>

This Article is brought to you for free and open access by the Anthropology at SJSU ScholarWorks. It has been accepted for inclusion in Faculty Publications, Anthropology by an authorized administrator of SJSU ScholarWorks. For more information, please contact scholarworks@sjsu.edu.

Authors

Alan M. Leventhal, Brian F. Byrd, Anna Cornellias, Jelmer W. Eerkens, Jeffrey Rosenthal, Tim R. Carpenter, and Jennifer A. Leonard

Title: The Role Of Canids In Ritual And Domestic Contexts: New Ancient DNA Insights From Complex Hunter-Gatherer Sites In Prehistoric Central California

Authors: Brian F. Byrd^{a*}, Anna Cornellás^b, Jelmer W. Eerkens^c, Jeffrey Rosenthal^a, Tim R. Carpenter^e, Alan Leventhal^d, and Jennifer A. Leonard^b

^a Far Western Anthropological Research Group, Davis, California

^b Conservation and Evolutionary Genetics Group, Estación Biológica de Doñana (EBD-CSIC), Seville, Spain

^c Department of Anthropology, University of California, Davis

^d College of Social Sciences, San Jose State University, San Jose, California

^e ArchaeoMetrics, Woodland, California

* Corresponding author: Tel: +530-756-3941, email address: brian@farwestern.com

Key words: ancient DNA, stable isotopes, canid interments, dogs, ritual, hunter-gatherers

Abstract:

This study explores the interrelationship between the genus *Canis* and hunter-gatherers through a case study of prehistoric Native Americans in the San Francisco Bay-Sacramento Delta area. A distinctive aspect of the region's prehistoric record is the interment of canids, variously classified as coyotes, dogs, and wolves. Since these species are difficult to distinguish based solely on morphology, ancient DNA analysis was employed to distinguish species. The DNA study results, the first on canids from archaeological sites in California, are entirely represented by domesticated dogs (including both interments and disarticulated samples from midden deposits). These results, buttressed by stable isotope analyses, provide new insight into the complex interrelationship between humans and canids in both ritual and prosaic contexts, and reveal a more prominent role for dogs than previously envisioned.

Highlights:

- Studied genus *Canis* interments and disarticulated remains
- Goal to distinguish between coyotes, dogs and wolfs
- Conducted ancient DNA and stable isotope analyses
- Positive results all domesticated dogs
- Gained new insight into role of dogs in among complex hunter-gatherers

1. Introduction

The genus *Canis* occupies a unique and enduring niche within ancient human societies, often figuring prominently as totemic symbols and within ceremonial and ritual events and also, in the case of the dog, in an array of functional contexts (Cook 2012; Russell 2010; Serpell 1995). Strong archaeological insight into the nature of these symbolic and prosaic relationships is often hampered by our inability to readily distinguish between canid species based on morphology alone. This study explores this topic by examining the interrelationship between canids and Native American hunter-gatherers in the San Francisco Bay/Sacramento Delta area of central California. This region has a long, well-dated sequence of prehistoric occupation and, during the Late Holocene, complex social organization and high population densities (comparable to the most sophisticated prehistoric hunter-gatherer societies documented worldwide; Lightfoot 1997; Lightfoot and Luby 2002; Milliken et al. 2007).

Animal interments, most notably of canids, are a noteworthy aspect of this region's Late Holocene record and provide an important glimpse into prehistoric ceremonial activities. Based on skeletal morphology, canid interments in the region have been most often classified by faunal analysts as coyotes (*Canis latrans*), less frequently as dogs (*Canis familiaris*), and only occasionally as wolves (*Canis lupus*) (Cambra et al. 1996; Heizer and Hewes 1940; Langenwaller 2005; Simons 2004). Disarticulated canid remains also occur in high frequencies within midden deposits at a number of sites (e.g., Simons 1992), suggesting canids may have had a significant utilitarian role as well. However, these remains rarely can be classified to the species level.

The considerable morphological similarity between domestic dogs, wild coyotes, and wild wolves can make distinguishing even complete skeletons difficult (Crockford 2000; Morey 1992). As a result, differences of opinion have emerged between faunal analysts regarding species assignment (e.g., Heizer and Hewes 1940; Langenwaller 1996). This ambiguity hampers our insights into symbolic and economic trends associated with the rise and persistence of complex hunter-gatherers in this region. Canids clearly were an integral aspect of prehistoric ritual and symbolic activities, and the ethnographic record in central California suggests that these three species played very different roles within Native Californian cosmology.

In order to gain a fresh perspective into this long-standing problem, we have employed ancient DNA (aDNA) analysis, a technique recently used elsewhere to distinguish canid species in archaeological contexts (e.g., Brown et al. 2012; Horsburgh 2008; Losey et al. 2011). It is also an approach advocated by Simons (2004:42) for addressing canid identification challenges in the San Francisco Bay Area. Stable isotope analyses were also conducted on some canids to gain insight into their diet, and to facilitate comparison with contemporaneous humans in the region (Bartelink 2009; Rick et al. 2011). We analyzed a sample of prehistoric canid remains from interments and from generalized midden deposits in the San Francisco Bay-Sacramento Delta region of central California (Figure 1). These prehistoric samples include interments previously classified as coyote, dog, and wolf based on morphology alone. The aDNA results are entirely represented by domesticated dogs (including interments and disarticulated samples from midden deposits). The results provide new insight into the complex interrelationships between humans and canids, and reveal a greater importance for the dog, the only prehistoric domesticated animal in California, than heretofore recognized.

In this paper we begin by providing a general context for the ritual and prosaic aspects of canids in the prehistory of western North America, focusing on central and southern California. Then we present the samples studied, analytical methods used, and results obtained. We conclude with a consideration of broader implications of these initial results, focusing on the implications for widespread presence of dog rather than wild canids for understanding complex hunter-gatherer practices.

2. Background

Some of the earliest evidence for the symbolic importance of canids is documented more than 12,000 years ago among the Natufian, complex hunter-gatherers of the Near East, when they were first buried with humans (Tchernov and Valla 1997). Dogs were domesticated from wolves in Eurasia during the Late Pleistocene (Lindblad-Tov et al. 2005; Vila et al. 1997). These domesticated dogs are believed to have then travelled with some of the early immigrants into the New World (Leonard et al. 2002). Once there, they encountered wild New World wolves and coyotes both of which were to play a prominent role in Native American cosmology.

Dogs, of course, fulfilled varied roles in Native American societies (Snyder and Leonard 2006:458). In some contexts they helped with hunting, functioned as early warning devices when strangers approached the village, were beasts of burden, and of course were companions. Along the northwest coast, they were even bred for their wool production. Dogs also sometimes served as a food source, a common occurrence worldwide in traditional societies (Simoons 1994:200-252). For example, among the Plains Indians ethnohistorically, dogs functioned as a famine food and were also sacrificed to honor visitors as a symbol of the importance of their friendship (Snyder 1991).

Morphological analyses of canid remains from archaeological sites have been used to suggest that there may have been some inter-breeding between canid species (Lupo and Janetski 1994; Snyder and Leonard 2006). This possibility is supported by the observation of such crosses in extant populations (Adams et al. 2003; Godinho et al. 2011; Muñoz-Fuente et al. 2010;). This potential adds to the challenge of distinguishing between these three species in the archaeological record.

In general, prehistoric canid interments are most often dogs and less frequently wild coyotes or wolves (Morey 2006). Wolves are very rarely documented, with notable examples from two sites in Siberia including one with ochre and a human skull from the Early Holocene (Bazaliiskiy and Savelyev 2003) and one with a human skull between its legs from the Middle Holocene (Losey et al. 2011). The latter wolf was confirmed using aDNA analysis.

The earliest canid interments (all classified anatomically as dogs) in North America appear to date to at least 8,500 years ago at Koster in the Illinois River valley (Morey and Wiant 1992). In a recent overview, Morey (2006) notes dog burials are emblematic of the Archaic period in North America, found typically as individual interments rather than buried together with humans. In western North America, animal interments of all types are infrequent prior to the Late Holocene, and they are most common in the last 1000 years. Canids in the Great Basin are most often reported from caves or from wetland sites, primarily in the western portion where they are occasionally associated with human burials (Danise 1990; Janetski et al. 1992; Lupo and Janetski

1994). Difficulties in distinguishing between canids are well-recognized, although most interments are classified as dogs. Other animal interments are rare or absent.

In the American Southwest, Hill's (2000) synthesis of animal interments reveals a complex spatial-temporal record that includes significant representation of canids, birds (raptors, macaws/parrots, and turkeys), and occasionally bears. Canids comprise 55% of all animal interments (total sample size of 164 interments and 206 individuals), and have a much longer Late Holocene temporal span (starting around 2,500 years ago) than bird interments (mainly between 1,000 and 600 years ago). Although many are only classified as canids, when species identifications are provided they are entirely classified as dogs. Contextually, canid interments in the Southwest are highly varied (Hill 2000:386-387). They occur in clusters, as multiple interments, and individually; they also occur periodically with human burials. Most are young and many have either cranial traumas or were interred headless. Contextually, they were recovered from floors of ritual and domestic structures, in pits, and in ventilator shafts.

In California, invariably the most common animal interments are identified as *Canis*, although other animals such as foxes, birds, and bears also occur. Animal interments are best documented in Central California and coastal Southern California. Canid interments are also highly varied, with ritual dismemberment more common in central California and on San Clemente Island in southern California than elsewhere (Hale and Salls 2000; Heizer and Hewes 1940). In these two localities, canid interments commonly have associated esoteric and utilitarian artifacts, including shell ornaments.

On the mainland of southern California, canid interments are infrequently reported (e.g., Langenwalter 2005; Winterbourne 1967:43,53), with most (17 individuals from 11 interments) from a single site that post-dates 1000 years ago (Langenwalter 1986). In contrast, canids are better documented on the Southern California Channel Islands; Vellanoweth et al. (2008:3119) state that 95 *Canis* interments have been recovered from 41 sites. Although caution is often used (Hale and Salls 2000), they are generally considered to be dogs, in large part because wolves and coyotes are not indigenous to the islands (Rick et al. 2008, 2011; Vellanoweth et al. 2008). Indigenous island fox interments, however, are well-represented on the Channel Islands.

The southern-most Channel Island, San Clemente, has yielded the most diverse and complex record of animal interments in southern California, and these are generally not associated with human burial grounds. Concentrations of ritual features dating to the last 1,000 years were recovered from several sites (Hale and Salls 2000; Hardy 2000; Raab et al. 1994; Salls and Hale 2000). These features included *Canis*, island fox, and bird interments. Some *Canis* interments were cut into sections and then interred with a wide range of associated offerings (red ochre, quartz crystals, bifaces, pipes, abalone shells, and baskets with seeds).

For the San Francisco Bay-Delta area in central California, the only synthesis of animal interments was an early study by Heizer and Hewes (1940) that addressed the Delta area only. They documented 30 animal interments from 10 sites, all dated to the last 1,000 years. *Canis* interments dominate (43%), along with bears, badgers, deer/elk, and antelope. Heizer and Hewes's (1940:589-590) canid sample (13 interments from five sites) were all classified anatomically as coyotes. Many (42%) lacked hindquarters and the vast majority (77%) had associated cultural material, including clusters of carved abalone pendants, clam shell disk beads, stone rods, a spear point, a charmstone, and a bone awl.

Since then, many more animal interments, including occasional birds, have been reported in the San Francisco Bay-Delta area, as well as in the nearby Sierra Nevada of central California (e.g., Cambra et al. 1996; Haag and Heizer 1953; Johnson 1970; Jones 2010; Langenwalter 1996; Peak 1976; Simons 2004). These more recent studies have confirmed that canids are the most common animal interment, and that the vast majority date to the last 1,000 years. Taxonomically, however, the canid record appears more complex. Notably, Langenwalter (1996:1) argues that the coyotes reported by Heizer and Hewes (1941) are actually dogs, and their work was "flawed by poor taxonomic identifications." Langenwalter (1996) does document a coyote interment within a larger sample of dog interments at a single site in the Sierra Nevada foothills. Canid interments from sites in the Bay Area have been variously reported as dogs (e.g., Haag and Heizer 1953; Hildebrandt and Mikkelsen 1993; Leventhal 1993:351;), coyotes (e.g., Gerow 1968:84; Wallace and Lathrap 1975:51), wolves (Cambra et al. 1996), or simply canids (Simons 2004).

A patchy ethnohistoric record (comprised of occasional first-hand accounts by early European explorers and colonizers and later anthropological writing based largely on memory culture) provides some insight into the role of canids in Native American populations residing in Central California around the time of Spanish contact (circa 1770 into the mid 1800s). Names for all three canids are present in every Native American language represented in Central California, consistent with mammalogists' assessment that coyotes and wolves were locally indigenous.

Coyotes figure more prominently than other canids in ethnohistoric accounts of central California Native religious beliefs and practices. For some, such as the Miwok and the Yokuts, coyotes were totemic symbols for lineages or moieties (Driver 1937; Gayton 1948). They also appear in ceremonial events, with individuals dressing as coyote dancers or clowns. Gayton (1948:29), in discussing totem animal redemption (the rite of paying for a ritual animal that was killed) among the southern Yokuts, notes "A dead coyote was "redeemed" in the same way by people of the Nutuwich moiety," but this was not, apparently, a public affair. Any Nutuwich person who wished to would pay for the coyote, whose carcass would then be buried, its hide being kept as a talisman." Dogs, in contrast, are generally relatively minor figures in religious mythology, and wolves are infrequently mentioned.

Varied opinions have been offered regarding the symbolic meaning of canid interments in California. Lagnenwalter (2005) suggests they typically represent prosaic disposal of personal property and pets after the owner's death. In contrast, Salls and Hale (2000) referred to the ritual dismemberment of canids on San Clemente Island as "the canid ceremony" and suggested it was part of annual mourning ceremonies that took place within ritual enclosures. A third perspective, first offered by Heizer and Hewes (1940), interpreted these interments as representing symbolic totem markings for moieties or lineages (Jones 2010; Langenwalter 1996). Most importantly, these views were invariably contingent upon the species assignment made by the researchers. Clearly, the challenge of distinguishing between species hinders our understanding of the nature of canid-related prehistoric activities.

3. Analysis

We analyzed mitochondrial DNA from a pilot sample of prehistoric canid remains recovered as interments and from generalized midden deposits in the San Francisco Bay-Delta region. This included 13 canid samples from seven prehistoric sites: one from ALA-329, one from MRN-5/H, one from SAC-21, three from SAC-99, three from SCL-732, one from SFR-4/H, and three from YOL-13 (Table 1). These samples came from both old archaeological projects (housed at the Phoebe A. Hearst Museum of Anthropology, University of California Berkeley and San Jose State University) as well as from recent projects.

All samples are from contexts that date to the last 2,000 years, and come from some of the most prominent sites in the region including several sites (SAC-21, SAC-99 and YOL-13) discussed initially by Heizer and Hewes (1940). Most importantly these samples include interments previously classified as coyote, dog, and wolf based on morphology alone. The samples selected for ancient DNA analysis were primarily individual teeth. Teeth are generally the most useful element to analyze because enough DNA can be obtained from the root so the crown can be returned intact for future morphological studies.

Stable isotope analysis was also conducted on a subset of the canid samples to gain insight into their diet, and to facilitate comparison with contemporaneous humans in the same region. The five samples were selected from sites with positive DNA results that had accessible skeletal elements appropriate for bone collagen extraction. They included one sample from ALA-329, three samples from SCL-732, and one sample from SFR-4/H.

3.1 Archaeological Contexts of Samples

Of the 13 samples, six from five separate sites (ALA-329, MRN-5/H, SCL-732, SFR-4/H, and YOL-13) yielded positive ancient DNA results. The archaeological context of the analyzed canid remains at each of these five sites is briefly summarized (Table 1). It should be noted that although the two sites with multiple samples yielded both positive and negative results (SCL-732 yielded one positive and two negative results, while YOL-13 yielded two positive results and one negative result), all samples from these sites are discussed below. The archaeological contexts of four samples taken

from canids at two additional prehistoric mounds (SAC-21 and SAC-99) along the Sacramento River are not presented since ancient DNA was not successfully extracted. Table 2 presents the Late Holocene chronological sequence for Central California used here, with periods and subdivisions within them based in large part on changes in predominant shell bead types, referred to as shell bead-style horizons (Groza et al. 2011).

ALA-329, the Ryan Mound, lies near the Coyote Hills along the southeast margin of San Francisco Bay. The site is an anthropogenic mound, some 135 by 90 meters in extent and almost 5 meters high (Coberly 1973; Leventhal 1993:31). Extensive excavations anchored by 39 radiocarbon dates document that the majority of this multicomponent mound dates to the Late Period, 685-180 calendar years before present (cal BP), underlain by Middle/Late Transition and Middle Period occupation horizons extending back until at least 2050 cal BP (Groza et al. 2011; Leventhal 1993:75-87; Wilson 1993). Of the 283 burials recovered from the site more than 80% appear to date to the Late Period, based on associated artifacts and stratigraphic position. A loosely flexed canid interment was recovered near the base of the Late Period deposit, and direct dating of the left tibia revealed the interment dates to the Middle/Late Transition or possibly the Middle 4 Period (OS-96418, 963 to 800 cal BP two sigma age range). The skeleton was found lying on its left side and associated with a harbor seal baculum (Figure 2). The canid interment was originally classified as a dog based on morphology (Leventhal 1993:351). This canid interment was sampled for ancient DNA and stable isotopes.

MRN-5/H is situated along the northwest edge of San Francisco Bay. This site is a small shell mound (38 by 15 meters) adjacent to the marsh of Richardson Bay, a small inlet immediately north of the Golden Gate. Recent excavations by Evans and Smith (2009) documented a rich, 1.5-meter-thick midden that included a diverse range of artifacts and a faunal assemblage dominated by clams and fish, along with water fowl, terrestrial mammals and sea mammals. Excavations also documented eight human burials. A series of four radiocarbon dates places the site in the Late Period (685-180 cal BP) and the Middle/Late Transition (930-685 cal BP). A complete canid skull, classified morphologically as a dog (Carpenter 2009), was recovered from the midden and subjected to DNA analysis.

SCL-732, the Kaphan Umux (Three Wolves) site, is located along the west side of Coyote Creek in the Santa Clara Valley. Broad-scale excavations revealed an extensive prehistoric deposit, concentrated in a 230 by 90 meter area, which included a structure, various hearth and platform-related features, 100 human burials, and several animal interments (Cambra et al. 1996). The human burial assemblage is well-dated to the Early/Middle Transition through the Middle 1 Period (2550-1530 cal BP). Many of the features, the structure, and at least one animal interment, however, are dated to the Late Period 2 (430-180 cal BP). The animal features, each separated by ~25 meters, include a single canid interment, a double canid interment, and a deer/snake interment (consisting of a headless snake and only the hind legs of a deer).

The three canid interments were all classified as wolves based on their morphology (Cambra et al. 1996) and each was sampled for DNA and stable isotopes as part of this study. The single canid interment (110-1) was loosely flexed, lying on its right side (Figure 3). This interment dates to the Late Period 2 based on two radiocarbon dates on canid bones (WSU-4604, 311 to -6 cal BP; OS-96402, 293 to -2 cal BP; two sigma age ranges:) and one date on charcoal from the pit (WSU-4605, 503 to 253 cal BP two sigma age range). In contrast, the double canid interment included a larger (111-1) and a smaller individual (111-2) buried on top of each other in a single pit, each positioned in a loosely flexed position. The larger, lower canid had a single charred three-strand braided rope, or possibly a net, “wrapped around the neck region and the hind quarters” (Cambra 1996:7.1). Dating results for these two canids are unsatisfactory: modern dates have been obtained on bone samples from each canid (OS-96379 and OS-96386), while a 5301 to 4729 cal BP date (two sigma range, WSU-4539) was obtained on the rope. In addition, a sequin bead (M1 type), with an age range of 1400 to 465 cal BP (Groza et al. 2011: Table 5) was recovered from the pit fill. Based on context, isotopic results, and ancient DNA results, these canids are most certainly indigenous and not modern, and most likely date to the latter portion of the prehistoric sequence, consistent with the Late Period dates on other features at the site.

SFR-4/H is situated on the east side of Yerba Buena Island within San Francisco Bay (Morgan and Dexter 2008). The site includes a 1.3-meter-thick shell midden well-dated to the Middle and Late periods, underlain by Early Period burials within dune

deposits (based on 27 radiocarbon dates; Rosenthal 2008). For much of the sequence, the faunal assemblage is dominated by sea mammals, water fowl, and fish. In the Late 1 period, however, terrestrial mammals greatly increase and represent 20% of the large mammal assemblage (Byrd 2008). Most of these Late 1 Period (685 to 430 cal BP) terrestrial mammal remains were classified morphologically as canids, including the DNA sample submitted for this study (Simons 2008). This sample was also analyzed for stable isotopes. The Late 1 Period is also noteworthy as it includes the only animal interment from the site: a golden eagle (*Aquila chrysaetos*) situated adjacent to a human burial (radiocarbon dated to 500-450 cal BP, two sigma age range, Beta-172582,).

Yol-13, the Mustang Mound, is situated southwest of the confluent between the Feather and Sacramento rivers (Taggart and Jackson 2005). This Sacramento Valley mound was 2.4 meters high and measured 70 by 45 meters, with radiocarbon dates (n=9) from the site revealing occupation concentrated in the Middle/Late Transition, with some earlier (Middle 4 Period) and later use (Late 2 Period) (Breschini et al. 1996; Groza et al. 2011). Initial excavations took place in the 1930s, and Heizer and Hewes (1940:590) report that one canid interment associated with a large, diagonally notched spear point and a charmstone was recovered in Middle/Late Transition contexts (930-685 cal BP). This canid was classified morphologically as a coyote. More extensive excavations took place from 1958-1961, yielding 112 human burials and 12 features, including additional canid interments, dating primarily to the Middle/Late Transition Period (900-700 cal BP) (Olsen 1995). Three samples from canid interments (here designated Canids 1-3) were subject to DNA analyses.

3.2 Analysis Methods

3.2.1 Ancient DNA

All pre-amplification steps were performed in a dedicated ancient DNA laboratory. To prevent possible contamination, this laboratory is physically isolated, has a private air-handling system, including positive pressure and HEPA (High-Efficiency Particulate Air) filters on all vents. Strict rules control access to the lab, and require proper clean attire under full overalls with head cover, dedicated shoes, face masks, and

gloves. No materials from the main lab or storage areas can enter the ancient DNA lab; all materials are bought separately and go directly into the ancient DNA lab. All surfaces and materials are cleaned regularly with bleach and ultra violet lights. The lab is divided into two rooms, one for handling teeth and bones (which in some cases may generate dust) and a separate higher pressure room for handling chemicals, extracting DNA, and setting up other reactions.

The correct extraction method depends on the particularities of the site where the sample originated, so some tests of the different methods on samples from each site were performed. A silica-based column extraction method and phenol-chloroform extraction method, followed by column purification and concentration were tested in two individuals. All further extractions were with the phenol-chloroform method as in Losey et al. (2011). Each batch of extractions included a small number of samples and multiple negative controls were carried through the amplification step.

Canid-specific primers which target about 425 of the 5' end of the mitochondrial control region and that have been developed for ancient DNA and extensively tested were used, in the pairs ThrL/ddl5; ddl1s/ddl3; ddl4/DLHc; ThrL/ dog1R; dog2F/ddl5 (Leonard et al. 2002, 2005, 2007; Losey et al. 2011; Muñoz-Fuentes 2009, 2010). These primer sets amplify short fragments, which are much more likely to be preserved in ancient material than longer fragments. These short fragments amplify a region that overlaps with adjacent fragment(s) as an additional control against constructing chimeric sequences. Negative controls were included in every polymerase chain reaction (pcr).

Ancient DNA can yield apparent changes in sequences due to degradation of the DNA since the animal died, and not to the presence of a mutation in the animal. The type of degradation that yields these apparent mutations should be random, so to identify these changes and remove them from the data set each fragment of each individual was replicated through multiple pcrs. The various sequences obtained from a single individual were aligned in the program Sequencher (Genecodes). If the sequence matched, it was considered confirmed. If a mismatch was identified, additional amplifications and sequencing were performed. The base pair at such sites was determined based on the most frequent base pair sequenced from three or more independently amplified products. Amplification was attempted a minimum of six times for each sample. Samples which

yielded no positive reaction were discarded after 6-15 negative reactions, and further effort was put into the remaining samples which yielded at least one positive reaction.

A large number of coyote, wolf and dog sequences are published and publically available (i.e. Hailer and Leonard 2008; Koblmuller et al. 2012; Leonard et al. 2002, 2005, 2007; Vilà et al. 1997, 1999). Sequences identified in the ancient material from this study were compared to all available sequences by BLAST search (<http://blast.ncbi.nlm.nih.gov/Blast.cgi>) to determine if the exact sequence has been previously identified in other animals. The sequences were then included in a data set of representative dog, wolf, and coyote sequences which was aligned with Clustal W v 1.83 (Larkin et al. 2007). This was used to construct a phylogeny using maximum likelihood with the web-based program RAxML (Stamatakis et al. 2008) and then visualized in Dendroscope (Hudson et al. 2007). Coyotes were assigned outgroup status to add directionality to the tree. If any of the unknown canids were coyote, this would not affect their placement with the coyotes in the phylogeny. This phylogeny enables individual canids to be assigned to species, and, for dogs, to clade.

3.2.2 Stable Isotopes

Five bone samples were also analyzed for carbon and nitrogen stable isotopes from bone collagen (C and N) and carbon and oxygen from bone apatite (C and O). The surface of each bone was cleaned by abrasion with a drill bit and washed and sonicated in deionized water. For collagen extraction, samples were demineralized by immersing them in 0.5M HCl at 1°C for five to 15 days. The HCl solution was replaced every one-two days until the sample no longer visibly reacted and was spongy in texture. Samples were then treated with 0.125M NaOH for 24 hours to remove humic contaminants, rinsed with dH₂O, immersed in pH≈3 water, and placed in an oven at 80°C for 24 hours to solubilize the collagen. Solubilized samples were freeze-dried. Collagen $\delta^{13}\text{C}$ and $\delta^{15}\text{N}$ was measured by continuous-flow mass spectrometry (PDZ Europa ANCA-GSL elemental analyzer interfaced to a PDZ Europa 20-20 isotope ratio mass spectrometer) at the Stable Isotope Facility at UC Davis. All samples yielded ample collagen (greater than 7% volume by weight) indicating excellent bone preservation. The atomic C/N ratio is also reported because it is a useful indicator of sample quality (DeNiro 1985; van Klinken

1999; Weber et al. 2005). Collagen from four samples (one from ALA-329 and three from SCL-732) was also submitted for AMS radiocarbon dating.

Apatite from sections of samples was also prepared for carbon and oxygen isotope analyses. Cleaned bone fragments were treated with 1.5 percent sodium hypochlorite to remove organic components (especially collagen), rinsed thoroughly with deionized water, and immersed in an acetic acid solution to remove soluble contaminants. $\delta^{13}\text{C}$ and $\delta^{18}\text{O}$ were measured using a GVI Optima Stable Isotope Ratio Mass Spectrometer at UC Davis.

4. Results

4.1 Ancient DNA

Of the 13 canid samples, six from five separate sites yielded positive ancient DNA results, the first on canids from archaeological sites in California (Table 3). These include four interments (ALA-329, SCL-732, YOL-13 Canid 2 and YOL-13 Canid 3) and two disarticulated samples from generalized midden deposits (MRN-5/H and SFR-4/H). Overall, the ancient DNA analysis documented the presence of only dogs in the Central California archaeological record, despite some of these canid interments being previously classified as coyotes and wolves (Figure 4).

Three of the six samples yielded complete or near complete replicated sequences for the 425 base pair targeted fragment. All three of these samples (MRN-5/H, SFR-4/H, and YOL-13 Canid 2) have been genetically confirmed to be dogs. Previously these samples had been anatomically classified as unspecified canid (SFR-4/H), coyote (YOL-13 Canid 2), and dog (MRN-5/H). A fourth sample yielded about 70% coverage for the 425 base pair targeted fragment. This sample (SCL-732 Canid 111-1) is genetically assigned a dog with high confidence. Based on morphology, this skeleton (as well as the smaller skeleton, 111-2, in the same pit) had been previously classified as a wolf.

The remaining two positive DNA results yielded short fragments of 106 and 107 base pairs, and were not successfully replicated. The fifth positive DNA sample (YOL-13 Canid 3) yielded a short fragment of 106 base pairs of sufficient resolution to be classified as dog. Previously, this YOL-13 interment had been morphologically classified

as a coyote. Finally, a sixth positive DNA sample (ALA-329) yielded a 107 base pair fragment that is less variable and only can be determined with high confidence to be a dog or wolf but not a coyote. Previously, the interment from ALA-329 had been morphologically classified as dog.

One of the dogs (SFR-4/H) was assigned to clade IV and all the others to clade I (following Vilà et al. 1997). This pattern, with most individuals belonging to clade I and a small number to clade IV, was also observed in pre-contact American dogs, primarily from Latin America (Leonard et al. 2002). In that study a high percentage of the dogs formed a group within clade I, referred to as clade *a*, which likely evolved in the Americas and apparently went extinct after contact with Europeans (Castroviejo-Fisher et al. 2011). None of the dogs sequenced here fell into that ancient America-specific clade.

4. 2 Stable Isotopes

Collagen stable isotope analysis was conducted on five samples: two samples confirmed by the aDNA study to be dogs (SFR-4/H and SCL-732 Interment 111-1) and one sample (ALA-329) where the ancient DNA results revealed the interment was either a dog or a wolf (but not a coyote), and two interments from SCL-732 (111-2 and 110-1) that lacked ancient DNA. Collagen C and N isotopes are controlled mainly by protein sources (Ambrose and Norr 1993; Froehle et al. 2009; Kellner and Schoeninger 2007; Tieszen and Fagre 1993). The results reveal a fairly tight distribution with respect to $\delta^{13}\text{C}_{\text{col}}$ (-16.7 to -19.8‰) and $\delta^{15}\text{N}$ (8.6 to 9.3‰), indicating a very similar diet (Table 4). Moreover, the aDNA-confirmed dog interment from SCL-732 (111-1) has an almost identical isotopic signature to the second interment in this feature (111-2, which lacked aDNA preservation), and the canid interment from ALA-329.

Our desire was to compare these values to those from humans from the same sites, and to prehistoric wild canids from the region. Unfortunately, isotopic data from humans are available for only some of the same sites as the canids from this study. Bartelink (2006) published isotope results on humans from ALA-329. No data are available from humans from SCL-732, however, data are available for humans from two nearby sites, SCL-134 (unpublished data from one of the authors, JWE) and SCL-287 (Bartelink 2010). Further, published isotopic data on prehistoric wild canids from the San

Francisco Bay region are, to our knowledge, lacking. To place our results in context, Figure 5 plots collagen isotopes from modern San Joaquin Valley kit foxes (Newsome et al. 2010), ancient California Channel Island foxes and domesticated dogs (Rick et al. 2011), and Pleistocene dire wolves and coyotes from the Los Angeles Basin (Coltrain et al. 2004).

The domesticated dogs from the California Channel Islands had a marine diet and so are completely unlike the canids in this study, and so are not illustrated in Figure 5 with the other stable isotope values. Humans from the Bay area, plotted as smaller symbols, tend to fall along a diagonal, while wild canids tend to fall to the left and above the humans. Food webs available to the wild canids and humans plotted in Figure 5 are not identical, making direct comparison difficult. However, overall this result suggests that *wild* canids in California are consuming protein more from terrestrial environments versus marine environments (less enriched $\delta^{13}\text{C}_{\text{col}}$) and from higher trophic levels (more enriched $\delta^{15}\text{N}$) than Bay area humans.

The five canids sampled for stable isotopes in this study are nearly identical in $\delta^{15}\text{N}$, ranging between 8.6 and 9.3‰. This range is significantly less than that observed among humans (F-test, two tailed, $p=.01$) and the prehistoric (F-test $p=.007$) and modern (F-test $p=.01$) wild canids. This suggests the five canids from archaeological contexts were gaining their dietary protein from a very consistent source (in terms of trophic level). Similarly, $\delta^{13}\text{C}_{\text{col}}$ in the five archaeological canids is more varied than $\delta^{15}\text{N}$, but still less variable than humans (F-test $p=.29$) and wild canids (F-test $p=.23$), again suggesting a consistent source for dietary protein. Absolute values for $\delta^{15}\text{N}$ and $\delta^{13}\text{C}_{\text{col}}$ for the dog from SFR-4/H and one of the canids lacking aDNA from SCL-732 overlap the bay area humans, suggesting a similar diet for these dogs and people. The remaining three samples comprise a tight cluster somewhat removed in isotopic space from the other samples, indicating diets close to the humans, but quite different than wild canids. The enriched carbon in these three samples suggests elevated input of marine (i.e., depleted) carbon, as C4 and CAM plants are rare in this part of California. As well, depleted $\delta^{15}\text{N}$ indicates relatively low-trophic-level sources of protein. Together, this suggests these three canids were consuming significant levels of low-trophic level marine foods, perhaps in the form of small fish or shellfish remains.

Figure 6 plots apatite $\delta^{13}\text{C}$ (-10.4 to -15.1‰) and $\delta^{18}\text{O}$ (-3.3 to -6.3‰) for the five samples in this study relative to the same set of Bay area humans (isotopic values for apatite were not available for the wild canids plotted in Figure 5). Again, isotopic values for the samples in this study are narrow in their spread, especially $\delta^{18}\text{O}$. Significantly, the canids overlap with the values from the humans. Because $\delta^{18}\text{O}$ is mostly controlled by water sources and $\delta^{13}\text{C}_{\text{apa}}$ by complete diet (Froehle et al. 2009; Kellner and Schoeninger 2007), these data suggest the canids in this study were drinking water and consuming carbon from a similar source as humans.

In sum, collagen and apatite stable isotope values from the dogs are similar to recent stable isotopic studies of Late Holocene human remains from sites in the San Francisco Bay area (Bartelink 2006; Beasley 2008). For example, Late Period human burials (n=8) at ALA-329 yielded collagen $\delta^{13}\text{C} = -16.4$ to -18.6 ‰ and $\delta^{15}\text{N} = 8.8$ to 11.8 ‰ (Bartelink 2009:Table 1). Similarly, Middle 1 Period occupation (circa 2150-1530 cal BP) at SCL-287 yielded $\delta^{13}\text{C} = -17.1$ to -19.3 ‰ and $\delta^{15}\text{N} = 6.5$ to 14.4 ‰ (Bartelink n.d.:5-5 to 5-6). This indicates that the diet of these prehistoric Native Californians was largely terrestrial with only modest contributions of marine foods. As well, the protein component of diets was dominated by lower trophic-level foods, such as plants and herbivores.

The isotope results suggest that the canids in this study had a diet similar to humans. An analogous trend was documented by Rick et al. (2011) for dogs and humans on Santa Rosa Island in southern California, revealing a commensal relationship between humans and domestic dogs. Indeed, this pattern has been found in archaeological studies globally where collagen has been analyzed from dogs and humans from the same site (e.g., Cannon et al. 1999; Germonpre et al. 2009; Guiry 2012). Such findings are consistent with the notion that domesticated dogs were fed by humans and, as a result, have a similar dietary composition. Overall, the isotope results from this study are consistent with the DNA results; namely that these canids are domesticated dogs and not wild wolves or coyotes.

5. Discussion

Our results are consistent with broader prehistoric trends that suggest that canid interments are most often dogs. The results also correspond well with the prevalence of dogs in interments on the Channel Islands, a setting where native wolves and coyotes were absent. The dogs identified in this ancient DNA study include three from prehistoric habitation sites along the edge of San Francisco Bay, one from the Santa Clara Valley, and two from the junction of the Sacramento and Feather rivers. All are from contexts dating to the last 1,000 years associated mainly with the Middle/Late Transition and Late Period.

It is interesting to note that these sites with ancient DNA evidence of domestic dogs fall within the ethnographic territories of the Ohlone, Coast Miwok, and Patwin (see Figure 1). Notably, this is the first definitive evidence that late prehistoric populations in the Coast Miwok and Patwin ethnographic territories had dogs. Kroeber (1941:6-7) had previously noted that the ethnographic record indicated that dogs were rare or absent north and east of San Francisco Bay. This is in contrast to neighboring groups, such as the Yokuts in the Central Valley and Sierra Nevada, that were reported to have bred dogs and traded puppies to nearby groups including the Miwok and possibly the Ohlone (Barrett and Gifford 1933:70; Driver 1937; Gayton 1936, 1948; Gifford 1926, 1955; Kroeber 1941).

While being cautious not to over-generalize from these initial results, it is worthwhile to discuss potential implications if further analyses reveal that most of the canid interments and disarticulated midden remains in the San Francisco Bay-Delta region are also dogs. Hill (2000:363-364), in the context of the American Southwest, provides a useful conceptual orientation and pragmatic approach to unraveling the role of animal interments in ancient societies, focusing on ritual behaviors expressed in the archaeological record rather than beliefs about animals. She distinguishes three types of animal interments: animal sacrifice and disposal as “ceremonial trash” often after portions of the body (such as wing feathers or hides) were retained for use in subsequent ritual activities (see also Walker 1995); dedicatory interment as an offering during a commemorative function (such as the founding or abandonment of a ceremonial structure); and simple interments/expedient disposal lacking perimortem trauma or contextual association. This interpretive approach stresses the importance of

distinguishing context, the cause of death, and what portions of the body were interred to understand the roles that animals played in ritual practices.

If dogs were mainly interred in the San Francisco Bay-Delta area, how does this impact insight into the underlying reasons? First, the consistent presence of esoteric artifacts and the occasional post-mortem removal of the hind quarters suggests that these interments may not just represent the disposal of the deceased personal property as often suggested (Langenwalter 2005:25). Second, the earlier interpretation that canid interments represent lineage or moiety totems appears only applicable if the interments were wolves or coyotes (e.g. Heizer and Hewes 1940:602; Langenwalter 1996). If one can apply direct historical analogy to the problem, then the dearth of dog totems ethnographically in the region reduces the likelihood that this interpretation readily explains most dog interments.

Instead, it appears likely that many of these dogs may have been ritually killed as part of specific prehistoric ceremonial activities. These activities would then have been followed by ceremonial disposal as an interment. Dog interments may also represent offerings of food to the dead as part of ceremonial events such as annual mourning rituals. The removal of the hind quarters from some interments may suggest that ritual consumption also occurred. There is often a complex interplay between ceremonial events and subsistence activities, and in a number of other contexts ethnographically in North America dogs figured prominently in ceremonial and feasting events.

Central California ethnographies provide anecdotal support for the role of dogs in various ceremonies. For example, Kroeber (1932:328) states that as part of the Kuksu initiation ceremony among the Patwin, a bandage was used to cover the initiation wound, and “This bandage has been dipped in the blood of a dog previously killed.” The Pota ceremony among the Central Miwok conducted to appease family members whose relative was killed by violence or where witchcraft was suspected, on occasion included the ceremonial killing of a dog. Dancers with bows and arrows ran through the village and shot dogs who entered a clearing within the village where the ceremony was taking place (Gifford 1926:397; 1955:195-196).

Gayton (1948: 154, 290) notes that the northern Yokuts may have eaten dogs at ceremonial events such as the ghost dance as well as at festivals. Similarly, in the fall of

1819 the Spanish soldier Estudillo witnessed and reported in his diary an annual mourning ceremony among the southern Yokuts when upland groups congregated at the foothill village of *Chischas* and conducted a ceremonial mock attack where dogs were killed, the dogs' owners compensated, and the dogs fed to the visitors: "The men arrived making skirmishes with their bows and arrows, killing dogs and chickens [*gallinas*] with permission from the Chischas, and afterward paid the latter with beads. Then they commenced to eat them with great pleasure" (translation in Gayton 1936:75). Similarly, speaking of the Yokuts, Powers (1877:379) states: "Dogs are reared (or were) largely for the flesh which they supply, which is accounted by them a special dainty, and which comes well in play, like the farmer's yellow-legged chicken, when other meat is scarce."

These central California ethnographic examples demonstrate that dogs were periodically used to feed guests/visitors, and in some contexts dogs may have been eaten on a more regular basis as well. In contrast, there are no indications in central California ethnographies that coyotes and wolves were eaten, and among some groups they were taboo foods (Gayton 1948; Kroeber 1932).

Ancient DNA results from our prehistoric interment and generalized midden samples also raise the possibility that disarticulated canid remains within generalized midden deposits in the region are mainly dogs. In many sites along the San Francisco Bay margin, canids represent an unusually high frequency of medium-large mammals, that at times rival the frequency of ungulates or sea mammals. For example, in an overview of vertebrate faunal assemblages, Simons (1992: Table 4.5) documents that five of the 11 assemblages had *Canis* remains representing 20 to 32% of identifiable large- and medium-sized mammals. If these high frequencies of canid remains are primarily dogs, then they may represent a periodic food source that served either as a famine food or were consumed at ceremonial events.

The suggestion that dogs were a food source in Central California is consistent with broader patterns in prehistory. As Snyder and Leonard (2006:458) note: "In some areas of the Americas, dogs served as a more regular meat source. The use of dogs as food is or was a nearly worldwide phenomenon (Simoons 1994:200-252), and in the Americas this practice was widespread (Driver and Massey 1957:182, map 6)." The importance of dogs as a food resource in North America appears to have included

contexts where they were a staple, where they were eaten in times of scarcity, and where they were only eaten in the context of ritual meals. A number of scholars have commented that the complex roles that dogs played in traditional societies often resulted in an ambivalent attitude (Russell 2010). Serpell (1995:248, 254) has noted: "... dog-eating is often associated with more complex psychological contortions" and "In symbolic terms, the domestic dog exists precariously in the no-man's-land between the human and non-human worlds."

As discussed by Snyder (1991:370-374) and Cail (2011) in studies of Plains and Canadian Plateau Indians, dogs have a high fat content compared to other food sources, and unlike wild animals, their fat content varies little between seasons since they scavenged human food remains. As such, dogs would have been an attractive food source during the winter and early spring when wild food resources were lean. Hayden (1995) has argued that feasts and ceremonial events invariably involved foods that were rare, tasty, or had high fat content. Dogs fit his prediction of likely foods to be consumed at feasts such as those documented ethnohistorically in Central California. Whether such activities took place only at the very end of the prehistoric record (between 1,000 and 170 cal BP) – the time frame of the dogs samples documented in this study – requires more in-depth research into the nature of the canid faunal record. A profitable focus of future investigations would be explore variation in canid-related activities between site types (such as at major mounds – potential ceremonial centers – versus smaller seasonal settlements) and within sites (i.e., domestic midden areas versus specialized contexts such as features and public areas).

6. Conclusion

Our results provide further indication of several trends with respect to ritual and symbolic activities associated with prehistoric animal interments in a slightly broader regional context in western North American. First, the record is primarily from the Late Holocene, especially the last 1,000 years. Though other animals are well-represented in Central California, the Channel Islands, and the Southwest, *Canis* interments are invariably the most ubiquitous. Interments of *Canis* are also highly varied, with ritual dismemberment most common in central California and San Clemente Island in southern

California. In these two localities, *Canis* interments commonly have associated artifacts. These trends suggest that most were sacrificed and then ceremonially interred, although some appear to represent dedicatory offerings. For San Clemente Island, Salls and Hale (2000) suggest that ritual dismemberment was an aspect of mourning ceremonies that took place in ritual enclosures.

In summary, the ancient DNA and isotopic results provide new insights into the relative importance of dogs, coyotes, and wolves in the archaeological record of the San Francisco Bay-Delta area. The complete dominance of dogs in this pilot sample points toward the importance of this domestic species and provides the opportunity to construct a fresh framework for understanding their importance in ceremonial and prosaic contexts. These results also highlight the difficulty of morphologically distinguishing species of *Canis* in the archaeological record, and so in cases where specific identification is important to the hypothesis, identification by ancient DNA analysis should be employed, if possible.

Acknowledgements

We thank the following individuals and institutions for supporting this study by providing access to archaeological collections: Joan Knudson and Kent Lightfoot, University of California, Berkeley, Phoebe A. Hearst Museum of Anthropology; Dr. J.A. English-Lueck, San Jose State University; Muwekma Ohlone Tribe; and Jennifer Darcangelo and California Department of Transportation. We also thank the Spanish government for funding support; and Natalie Caulk, Susan Cook, Elizabeth Hodges, Jared Lam, and Howard Spero of UC Davis for assistance with the stable isotope analyses. We also thank Far Western's Tammara Norton and Kathleen Montgomery for drafting the map and the graphs and Pat Mikkelsen for reviewing and editing an earlier version of the manuscript. Logistical support was provided by Laboratorio de Ecología Molecular, Estación Biológica de Doñana, CSIC (LEM-EBD).

Figures List:

1. San Francisco Bay-Delta area showing archaeological sites discussed in text.
2. Canid interment from ALA-329.
3. Anterior portion of canid interment 111-1 from SCL-732
4. Maximum likelihood phylogeny of canids from California archaeological sites in this study (highlighted in bold) in relation to previously published domestic dogs (prefix D) from the four main clades, gray wolves (prefix lu) and coyotes. Partial sequences are marked with an asterisk.
5. Bivariate plot of nitrogen and carbon collagen stable isotope ratios for dogs in this study in relationship to available Bay area prehistoric Native American human remains and available California area wild canids.
6. Bivariate plot of oxygen and carbon apatite isotope ratios for dogs in this study in relationship to available Bay area prehistoric Native American human remains.

Table List:

1. Summary of site contexts with positive results from the ancient DNA analysis of canids.
2. Late Holocene prehistoric chronological Sequence for San Francisco Bay Area.
3. Ancient DNA Sample Results
4. Stable Isotope results from canid bone collagen

References

Adams J.R., Leonard J.A., Waits, L.P., 2003. Widespread occurrence of a domestic dog mitochondrial DNA haplotype in southeastern USA coyotes. *Molecular Ecology* 12, 541-546.

Ambrose, S.H., Norr, L., 1993. Experimental evidence for the relationship of the carbon isotope ratios of whole diet and dietary protein to those of bone collagen and carbonate, in Lambert, J.B., Grupe G. (Eds.), *Prehistoric Human Bone: Archaeology at the Molecular Level*. Springer-Verlag, Berlin, pp. 1–37.

Barrett, S.A., Gifford E.W., 1933. *Miwok Material Culture: Indian Life of the Yosemite Region*, Volume 2(4). Milwaukee Museum, Milwaukee, Wisconsin, pp. 117-376.

Bartelink, Eric J., 2006. *Resource Intensification in Pre-Contact Central California: A Bioarchaeological Perspective on Diet and Health Patterns among Hunter-Gatherers from the Lower Sacramento Valley and San Francisco Bay*. Unpublished Ph.D. dissertation, Department of Anthropology, Texas A&M University, College Station, Texas.

Bartelink, Eric J., 2009. Late Holocene Dietary Change in the San Francisco Bay Area: Stable Isotope Evidence for an Expansion in Diet Breadth. *California Archaeology* 1(2):227-252.

Bartelink, Eric J., 2010. Paleodietary Analysis of Human Remains from Yuki Kutsuimi Šaatoš Inūxw (Sand Hill Road) Sites: CA-SCL-287 and CA-SCL-263. In *Final Report on the Burial and Archaeological Data Recovery Program Conducted on a Portion of a Middle Period Ohlone Cemetery, Yuki Kutsuimi Šaatoš Inūxw (Sand Hill Road) Sites: CA-SCL-287 and CA-SMA-263*, Stanford University, California (Vol. II), Leventhal A. et al. (ed.); Pp. 5-1 to 5-16.

Bazaliiskiy, V.I., Savelyev, N.A., 2003. The wolf of Baikal: the “Lokomotiv” early Neolithic cemetery in Siberia (Russia). *Antiquity* 77, 20–30.

Beasley, M.M., 2008. Dietary Trends of the Ellis Landing Site (CA-CCO-295): Stable Carbon and Nitrogen Isotope Analysis of Prehistoric Human Remains from a San Francisco Bay Area Shellmound. Unpublished MA thesis, Department of Anthropology, California State University, Chico.

Breschini, Gary S., Haversat, Trudy, Erlandson, Jon, 1996. *California Radiocarbon Dates*, Eighth Edition. Coyote Press, Salinas, California.

Brown, Sarah K., Darwent, Christyann M., Sacksa, Benjamin N., 2012. Ancient DNA evidence for genetic continuity in arctic dogs. *Journal of Archaeological Science*, in press.

Byrd, Brian F., 2008. Subsistence Patterns in a Regional Context. In *San Francisco-Oakland Bay Bridge East Span Seismic Safety Project - Archaeological Analysis of CA-SFR-4/H, Yerba Buena Island, San Francisco and Alameda Counties, California*, by Sally Morgan and Sean Dexter, pp. 105-117. Report on file Northwest Information Center, Sonoma State University.

Cail, Hannah S., 2011. *Feasting on Fido: Cultural Implications of Eating Dogs at Bridge River*. Unpublished Masters Thesis, Department of Anthropology, University of Montana, Missoula, Montana.

Cambra, Rosemary, Leventhal, Alan, Jones, Laura, Hammett, Julia, Field, Les, Sanchez, Norma, Jurmain, Robert, 1996. *Archaeological Investigations at Kaphan Umux (Three Wolves) Site, CA-SCL-732: A Middle Period Prehistoric Cemetery on Coyote Creek in Southern San Jose, Santa Clara County, California*. Report on file Northwest Information Center, Sonoma State University.

Cannon, A., Schwarcz, H.P., Knyf, M. 1999. Marine-based Subsistence Trends and the Stable Isotope Analysis of Dog Bones from Namu, British Columbia. *Journal of Archaeological Science* 26:399-407.

Carpenter, Tim R., 2009. Appendix E: Faunal Analysis Report. In Results of an archeological monitoring program for the construction of the Fireside Inn Affordable Housing Project, at the site of CA-MRN-05/H, 115 Shoreline Highway, Mill Valley, Marin County, California, by Evans, Sally R. and Craig P. Smith. Report on file Northwest Information Center, Sonoma State University.

Castroviejo-Fisher, Santiago, Pontus Skoglund, Raul Valadez, Carles Vilà and Jennifer A Leonard, 2011. Vanishing native American dog lineages. *BMC Evolutionary Biology* 11: 73.

Coberly, Mary B., 1973. The Archaeology of the Ryan Mound, Site ALA-329, a Central California Coastal Village Site. University of Northern Colorado Occasional Publications in Anthropology Archaeology Series No. 4. NWIC: S-011031.

Coltrain, Joan B. John M. Harris, Thure E. Cerling, James R. Ehleringer, Maria-Denise Dearing, Joy Ward and Julie Allen, 2004. Rancho La Brea stable isotope biogeochemistry and its implications for the palaeoecology of late Pleistocene coastal southern California. *Palaeogeography, Palaeoclimatology, Palaeoecology* 205: 199-219.

Cook, Robert A., 2012. Dogs of War: potential social institutions of conflict, healing and death in a Forth Ancient Village. *American Antiquity* 77:498-523.

Crockford, S.J., 2000. A commentary on dog evolution: regional variation, breed development and hybridization with wolves. In *Dogs through time: an archaeological perspective*. 295 – 312, ed. S. J. Crockford. BAR International Series 889. Archaeopress, Oxford.

Dansie, Amy, 1990. Prehistoric Carnivore Usage in the Wetland Habitats of Western Nevada. In: Wetland Adaptations in the Great Basin, Joel C. Janetski and David B. Madsen, eds., pp. 159-172. Brigham Young University, Museum of Peoples and Cultures Occasional Papers No. 1, Provo Utah.

DeNiro, M. J. 1985. Postmortem Preservation and Alteration of *in vivo* Bone-Collagen Isotope Ratios in Relation to Paleodietary Reconstruction. *Nature* 317: 806-809.

Driver, Harold. E., 1937. Culture Element Distributions: VI. Southern Sierra Nevada. *University of California Anthropological Records* 1(2).

Driver, Harold. E. and William C. Massey, 1957. Comparative Studies of North American Indians. *Transactions of the American Philosophical Society* 47(2), Philadelphia.

Evans, Sally R. and Craig P. Smith, 2009. Results of an archeological monitoring program for the construction of the Fireside Inn Affordable Housing Project, at the site of CA-MRN-05/H, 115 Shoreline Highway, Mill Valley, Marin County, California. Report on file Northwest Information Center, Sonoma State University.

Froehle, A.W., Kellner, C.M., Schoeninger, M.J., 2010. FOCUS: effect of diet and protein source on carbon stable isotope ratios in collagen: follow up to Warinner and Tuross (2009). *Journal of Archaeological Science*, 37, 2662–2670.

Gayton, Ann H. 1936. Estudillo among the Yokuts: 1819. In *Essays in Anthropology presented to A.L. Kroeber in Celebration of his sixtieth birthday*, edited by Robert H. Lowie, pp. 67-85. University of California Press, Berkeley, California.

Gayton, Ann H., 1948. Yokuts and Western Mono Ethnography. I: Tulare Lake, Southern Valley, and Central Foothill Yokuts. *University of California, Anthropological Records* 10(1): 1-142.

Germonpre, M., Sablin, M.V., Stevens, R.E., Hedges, R.E.M., Hofreiter, M., Stiller, M., Despres, V.R., 2009. Fossil dogs and wolves from Palaeolithic sites in Belgium, the Ukraine and Russia: osteometry, ancient DNA and stable isotopes. *Journal of Archaeological Science* 36:473-490.

Gerow, Bert A. with Roland W. Force, 1968. *An Analysis of the University Village Complex: with a Reappraisal of Central California Archaeology*. Stanford University Press, Palo Alto, California.

Gifford, Edward W., 1926. Miwok Cults. *University of California Publications in American Archaeology and Ethnology* 18(3), 391-408.

Gifford, Edward W., 1955. Central Sierra Miwok Ceremonies. *University of California Publications in American Archaeology and Ethnology* 14(4), 261-318.

Godinho et al. 2011 Genetic evidence for multiple events of hybridizations between wolves and domestic dogs in the Iberian Peninsula. *Molecular Ecology* 20, 5154-5166.

Groza, Randall G., Jeffrey Rosenthal, John Southon, and Randall Milliken, 2011. A Refined Shell Bead Chronology for Late Holocene Central California. *Journal of California and Great Basin Anthropology* 31(2): 135-154.

Guiry, Eric J., 2012. Dogs as Analogs in Stable Isotope-Based Human Paleodietary Reconstructions: A Review and Considerations for Future Use. *Journal of Archaeological Method and Theory* 19(3): 351-376.

Haag, William G. and Robert F. Heizer, 1953. A Dog Burial from the Sacramento Valley. *American Antiquity* 18, 263-265.

Hailer F and JA Leonard. 2008. "Hybridization among three native North American *Canis* species in a region of natural sympatry" *PloS one* 3: e3333.

Hale, A., Salls, R.A., 2000. The canine ceremony: dog and fox burials of San Clemente Island. *Pacific Coast Archaeological Society Quarterly* 36, 80-95.

Hardy, A.T., 2000. Religious aspects of the material remains from San Clemente Island. *Pacific Coast Archaeological Society Quarterly* 36, 78–96.

Hayden, Brian, 1995. Pathways to Power: Principles for Creating Socioeconomic Inequalities. *Foundations of Social Inequality*, edited by T. Douglas Price and Gary Feinman, pp. 15-86. Plenum Press, New York.

Heizer, Robert F. and Gordon W. Hewes, 1940. Animal ceremonialism in Central California in the light of archaeology. *American Anthropologist* 42, 587–603.

Hildebrandt, William R., and Patricia Mikkelsen, 1993. *Archaeological Test Excavations at Fourteen Sites along Highways 101 and 152, Santa Clara and San Benito Counties, California, Volume I, Prehistory*. Report on file Northwest Information Center, Sonoma State University.

Hill, Erica, 2000. The Contextual Analysis of Animal Interments and Ritual Practice in Southwestern North America. *Kiva* 65, 361-398.

Horsburgh, K. Ann, 2008. Wild or domesticated? An ancient DNA approach to canid species identification in South Africa's Western Cape Province. *Journal of Archaeological Science* 35, 1474-1480.

Hudson, Daniel H., Daniel C. Richter, Christian Rausch, Tobias DeZulian, Markus Franz and Regula Rupp, 2007. Dendroscope: An interactive viewer for large phylogenetic trees. *BMC Bioinformatics* 8:460.

Janetski, Joel C , Karen D. Lupo, John McCullough, and Shaimon Novak, 1992. The Mosida Burial: A Middle Archaic Burial from the Eastern Great Basin. *Journal of California and Great Basin Anthropology* 14(2), 180-200.

Johnson, J.J., 1970. Archaeological investigations at the Applegate site (4-Ama-56). University of California, Center for Archaeological Research at Davis, Publications 2: 65-144.

Jones, Barbara L., 2010. Mythical implications of faunal assemblages from three Ohlone sites. Unpublished Masters Thesis, Anthropology Department, San Francisco State University.

Kellner, C.M., Schoeninger, M.J., 2007. A simple carbon model for reconstructing prehistoric human diet. *American Journal of Physical Anthropology*, 133, 1112–1127.

Koblmüller S, Robert K Wayne and Jennifer A Leonard. 2012. Impact of Quaternary climatic changes and interspecific competition on the demographic history of a highly mobile generalist carnivore, the coyote. *Biology Letters* 8:644-647.

Kroeber, A.L., 1941. Culture Element Distributions: XV. Salt, Dogs, Tobacco. *University of California Anthropological Records* 6(1):1–20

Kroeber, A.L., 1932. The Patwin and Their Neighbors. *University of California Publications in American Archaeology and Ethnology*, Vol. 29(4):253-423.

Langenwalter, Paul E., II. , 1986. Ritual animal burials from the Encino Village Site. *Pacific Coast Archaeological Society Quarterly* 22(3), 63–97.

Langenwalter, Paul. E., II, 1996. Animal Burials from the Skyrocket Village Site (CA-CAL-629/630), Calaveras County, California. In *Skyrocket Faunal and Floral Appendix*,

edited by Marks La Jeunesse, Roger, and John H. Pryor. Prepared by California State University, Fresno.

Langenwalter, Paul E., 2005. A Late Prehistoric Dog Burial Associated with Human Graves in Orange County, California. *Journal of Ethnobiology* 25, 1-25.

Larkin MA, Blackshields G, Brown NP, Chenna R, McGettigan PA, McWilliam H, Valentin F, Wallace IM, Wilm A, Lopez R, Thompson JD, Gibson TJ, Higgins DG. (2007). [Clustal W and Clustal X version 2.0](#). *Bioinformatics*, 23, 2947-2948.

Leonard Jennifer A, Robert K Wayne, Jane Wheeler, Raul Valadez, Sonia Guillén and Carles Vilà. 2002. Ancient DNA evidence for Old World origin of New World dogs. *Science* 298, 1613-1616.

Leventhal, Alan M., 1993. A Reinterpretation of some Bay Area Shell Mounds: A View from the Mortuary Complex, ALA-329. Unpublished Master's thesis, Department of Social Sciences, San Jose State University, San Jose.

Leonard, Jennifer A, Carles Vilà and Robert K Wayne, 2005. Legacy lost: genetic variability and population size of extirpated US gray wolves (*Canis lupus*). *Molecular Ecology* 14: 9-17.

Leonard Jennifer A, Carles Vilà, Kena Fox-Dobbs, Paul L Koch, Robert K Wayne and Blaire Van Valkenburgh, 2007. Megafaunal extinctions and the disappearance of a specialized wolf morph. *Current Biology* 17: 1146-1150.

Lightfoot, Kent G., 1997. Cultural Construction of Coastal Landscapes: A Middle Holocene Perspective from San Francisco Bay. In *Archaeology of the California Coast during the Middle Holocene*, edited by Jon M. Erlandson and Michael A. Glassow, pp. 129-142. *Perspectives in California Archaeology* 4, Jeanne E. Arnold. Institute of Archaeology, University of California, Los Angeles,

Lightfoot, Kent G., and Edward M. Luby, 2002. Late Holocene in the San Francisco Bay Area: Temporal Trends in the Use and Abandonment of Shell Mounds in the East Bay. In *Catalysts to Complexity: Late Holocene Societies of the California Coast*, edited by Jon M. Erlandson and Terry L. Jones, pp. 263-281. Cotsen Institute of Archaeology, University of California, Los Angeles.

Lindblad-Toh, K., Wade, C.M., Mikkelsen, T.S., Karlsson, E.K., Jaffe, D.B., Kamal, M., Clamp, M., Chang, J.L., Kulbokas, E.J., Zody, M.C., et al. 2005. Genome sequence, comparative analysis and haplotype structure of the domestic dog. *Nature* **438**: 803–819.

Losey, Robert J., Vladimir I. Bazaliiskii, Sandra Garvie-Lok, Mietje Germonpré, Jennifer A. Leonard, Andrew L. Allen, M. Anne Katzenberg, Mikhail V. Sablin. 2011. Canids as persons: Early Neolithic dog and wolf burials, Cis-Baikal, Siberia. *Journal of Anthropological Archaeology*. 30, 174-189.

Lupo, Karen D. and Janetski, Joel C., 1994. Evidence of Domesticated Dogs and Some Related Canids in the Eastern Great Basin. *Journal of California and Great Basin Anthropology* 16: 2, 199-220.

Milliken, Randall, Richard T. Fitzgerald, Mark G. Hylkema, Randy Groza, Tom Origer, David G. Bieling, Alan Leventhal, Randy S. Wiberg, Andrew Gottsfield, Donna Gillette, Viviana Bellifemine, Eric Strother, Robert Cartier, and David A. Fredrickson, 2007. Punctuated Culture Change in the San Francisco Bay Area. In *California Prehistory: Colonization, Culture, and Complexity*, Terry L. Jones and Kathryn Klar, pp. 99-124. Altamira Press, Walnut Creek, California.

Morey, Darcey F., 1992. Size, Shape, and Development in the Evolution of the Domestic Dog. *Journal of Archaeological Science* 19(2):181-203.

Morey, Darcy F, 2006. Burying key evidence: the social bond between dogs and people. *Journal of Archaeological Science* 33, 158-175.

Morey, Darcy F. and Michael D. Wiant, 1992. Early Holocene Dog burials from the North American Midwest. *Current Anthropology* 33, 224-229.

Morgan, Sally S., and Sean D. Dexter, 2008. San Francisco-Oakland Bay Bridge East Span Seismic Safety Project - Archaeological Analysis of CA-SFR-4/H, Yerba Buena Island, San Francisco and Alameda Counties, California. Report on file Northwest Information Center, Sonoma State University.

Muñoz-Fuentes Violeta, Chris T Darimont, Robert K Wayne, Paul Paquet and Jennifer A Leonard, 2009. Ecological factors drive differentiation in wolves from British Columbia. *Journal of Biogeography* 36: 1516-1531.

Muñoz-Fuentes V, CT Darimont, P Paquet and JA Leonard. 2010. "The genetic legacy of extirpation and re-colonization in Vancouver Island wolves." *Conservation Genetics* **11**: 547-556, doi: 10.1007/s10592-009-9974-1.

Newsome, S.D., Ralls, K., Job, C.V.H., Fogel, M.L., Cypher, B.L., 2010. Stable isotopes evaluate exploitation of anthropogenic foods by the endangered San Joaquin kit fox (*Vulpes macrotis mutica*). *Journal of Mammalogy*, 91, 1313-1321.

Olsen, W.H., 1995. A Look at a Middle/Late Transition Site in Central California: The Mustang Site, CA-Yol-13. Paper presented at the 29th Annual Meeting of the Society for California Archeology in Eureka, California.

Peak, A.S., 1976. Buchanan Reservoir salvage project, Madera County, California: Archaeological Excavation. Report on file, Southern San Joaquin Valley Information Center, CSU Bakersfield, California.

Powers, Stephen, 1877. Tribes of California. US Department of the Interior, Geographical and Geological Survey of the Rocky Mountain Region, Washington, DC. (Reprinted in 1976, University of California Press. Berkeley and Los Angeles).

Raab, L.M., Bradford, K.G. and Yatsko, A., 1994. Advances in southern Channel Islands archaeology: 1983 to 1993. *Journal of California and Great Basin Anthropology* 16, 243–70.

Rick, Torben C., Phillip L. Walker, Lauren M. Willis, Anna C. Noah, Jon M. Erlandson, Rene L. Vellanoweth, Todd J. Braje, and Douglas J. Kennett, 2008. Dogs, Humans and island ecosystems: the distribution, antiquity, and ecology of domestic dogs (*Canis familiaris*) on California's Channel Islands. *Holocene* 18, 1077-1087.

Rick, Torben C., Brendan J. Culleton, Carley B. Smith, John R. Johnson, Douglas J. Kennett. 2011. Stable isotope analysis of dog, fox, and human diets at a Late Holocene Chumash village (CA-SRI-2) on Santa Rosa Island, California. *Journal of Archaeological Science* 38, 1385-1393.

Rosenthal, Jeffrey, 2008 Stratigraphy, Chronological Indicators, and Chronostratigraphy and Component Definition. In San Francisco-Oakland Bay Bridge East Span Seismic Safety Project - Archaeological Analysis of CA-SFR-4/H, Yerba Buena Island, San Francisco and Alameda Counties, California, by Sally Morgan and Sean Dexter, pp. 65-88. Report on file Northwest Information Center, Sonoma State University.

Russell, Nerissa, 2010. Navigating the Human-Animal Boundary. *Reviews in Anthropology* 39(1), 3-24.

Salls, R.A., and A. Hale, 2000. Messenger to the Great Spirit. *Pacific Coast Archaeological Society Quarterly* 36, 95-101.

Serpell, James, 1995. From Paragon to Pariah: Some Reflections on Human Attitudes to Dogs. In *The Domestic Dog: Its Evolution, Behaviour, and Interactions with People*, edited by James Serpell, pp. 246-256. Cambridge: Cambridge University Press.

Simons, Dwight D., 1992. Prehistoric Mammal Exploitation in the San Francisco Bay Area. In *Essays on the Prehistory of Maritime California*, edited by Terry L. Jones, pp. 73-104. Center for Archaeological Research at Davis Publication, University of California, Davis.

Simons, Dwight D., 2004. Vertebrate faunal remains. Santa Clara Valley Prehistory: Archaeological Investigations at CA-SCL-690, the Tamien Station Site, San Jose, California. Report on file, Northwest Information Center, Sonoma State University.

Simons, Dwight D., 2008. Appendix E: Faunal and Floral Remains. In *San Francisco-Oakland Bay Bridge East Span Seismic Safety Project Archaeological Analysis of CA-SFR-4/H, Yerba Buena Island*, edited by Sally Morgan and Sean Dexter, Prepared for California Department of Transportation, District 4, Oakland.

Simoons, Frederick J., 1994. *Eat not this flesh: food avoidances from prehistoric to the present*. Madison, University of Wisconsin, Madison.

Snyder, Lynn M., 1991. Barking mutton: ethnohistoric and ethnographic, archaeological and nutritional evidence pertaining to dogs as a native American food resource on the Plains. In: J.R. Purdue, W.E. Klippel, B.W. Styles (Eds.), *Beamers, Bobwhites, and Blue-Points: Tributes to the Career of Paul W. Parmalee*, Scientific Papers 23, Illinois State Museum, Springfield, Illinois, and Report of Investigations 22, Department of Anthropology, University of Tennessee, pp. 359-378.

Snyder Lynn M. and Jennifer A. Leonard, 2006. Dog. In *Environment, Origins, and Population*, vol. 3, edited by Douglas H. Ubelaker, pp. 452-462, *Handbook of North American Indians*. Smithsonian Institution, Washington D.C.

Stamatakis, Alexandros, Paul Hoover and Jacques Rougemont, 2008. A rapid bootstrap algorithm for the RAxML web servers. *Systematic Biology* 57, 758-771.

Taggart, Michael and Robert Jackson, 2005. Cultural Resources Inventory, Fremont Landing Bank, Yolo County, California. Report on file Northwest Information Center, Sonoma State University.

Tchernov, Eitan and François F. Valla, 1997. Two New Dogs, and Other Natufian Dogs, from the Southern Levant. *Journal of Archaeological Science* 24, 65–95.

Tieszen, L.L., Fagre, T., 1993. Effect of diet quality and composition on the isotopic composition of respiratory CO₂, bone collagen, bioapatite, and soft tissues. J.B. Lambert, G. Grupe (Eds.), *Prehistoric Human Bone: Archaeology at the Molecular Level*, Springer-Verlag, Berlin, pp. 121–155.

van Klinken, G. J., 1999. Bone collagen quality indicators for palaeodietary and radiocarbon measurements. *Journal of Archaeological Science* 26:687-695.

Vellanoweth, Rene', Barney G. Bartelle, Amira F. Ainis, Amanda C. Cannon, and Steven J. Schwartz, 2008. A double dog burial from San Nicolas Island, California, USA: osteology, context, and significance. *Journal of Archaeological Science* 35, 3111–3123.

Vilà, Carles, Peter Savolainen, Jesús E. Maldonado, Isabel R. Amorim, John E. Rice, Rodney L. Honeycutt, Keith A. Crandall, Joakim Lundeberg, Robert K. Wayne, 1997. Multiple and Ancient Origins of the Domestic Dog. *Science* 276 (5319):1687-1689.

Vilà, Carles, Isabel R Amorim, Jennifer A Leonard, David Posada, Javier Castroviejo, Francisco Petrucci-Fonseca, Keith A Crandall, Hans Ellegren and Robert K Wayne, 1999. Mitochondrial DNA phylogeography and population history of the grey wolf *Canis lupus*. *Molecular Ecology* 8:2089-2103.

Walker, William H., 1995. Ceremonial Trash? In *Expanding Archaeology*, edited by James M. Skibo, W. H. Walker, and A. E. Nielsen, pp. 67-79. University of Utah Press, Salt Lake City.

Wallace, William J., and D. W. Lathrap, 1975. West Berkeley (CA-ALA-307): A Culturally Stratified Shellmound on the East Shore of San Francisco Bay. Volume 29. University of California Press, Berkeley.

Weber, A., McKenzie, H.G., Beukens, R., Goriunova, O.I., 2005. Evaluation of radiocarbon dates from the Middle Holocene hunter-gatherer cemetery Khuzhir-Nuge XIV, Lake Baikal, Siberia. *Journal of Archaeological Science* 32:1481-1500.

Wilson, Glen B., 1993. The Archaeological Collection from CA-ALA-329, the Ryan Mound, Alameda County, California. *Coyote Press Archives of California Prehistory* 39.

Winterbourne, J. W., 1967. Report of the Goff's Island Site. Excavation, May 1, 1939 to January 1940 (WPA). *Pacific Coast Archaeological Society Quarterly* 3(1), 1-156.

Table 1. Summary of site contexts with positive results from the ancient DNA analysis of canids.

Site (CA-)*	Setting	Ethnographic Territory	Site Character	Temporal Span (Period) Associated with Canid Sample (see Table 2)	Context	Original Anatomical Classification	aDNA Samples Studied	Isotope Samples Studied
ALA-329	Southeast San Francisco Bay	Ohlone	Shell mound	960-800 cal BP (Middle 4 to Middle/Late Transition)	Interment	Dog (Levanthal 1993:351)	1 tooth	Left tibia
MRN-5 /H	Northwest San Francisco Bay	Coast Miwok	Shell mound	960-180 cal BP (Middle/Late Transition to Late)	Disarticulated cranium in midden	Dog (Carpenter 2009)	1 tooth	n/a
SCL-732	Santa Clara Valley	Ohlone	Shell midden	685-180 cal BP (Late)	Double interment (111-1 and 111-2) and single interment (110-1)	Wolves (Cambra et al. 1996:7.1)	3 teeth	Left radii (110-1, 111-1), left tibia (111-2)
SFR-04/H	Yerba Buena Island	Ohlone	Shell midden	685-430 cal BP (Late 1)	Disarticulated bone in midden	Canid (Morgan and Dexter 2008)	1 metatarsal	metatarsal
YOL-13	Sacramento River/Feather River junction	Patwin	Earth mound	930-685 cal BP (Middle/Late Transition)	Three interments (Canids 1-3)	Coyotes (Heizer and Hewes 1940: 590)	3 teeth	n/a

Table 2. Late Holocene chronological sequence for San Francisco Bay-Delta region.

Period*	Bead-style horizon	Time Range (cal BP)	Duration (years)
Historic/Mission	Historic/Mission	180-115	65
Late	Late 2	430-180	250
	Late 1	685-430	255
Middle-Late Transition	MLT	930-685	245
Middle	Middle 4	1200-930	270
	Middle 3	1355-1200	155
	Middle 2	1530-1355	175
	Middle 1	2150-1530	620
Early-Middle Transition	EMT	2550-2150	400
Early	Early	4000-2550	1450

*After Groza et al. (2011), using Dating Scheme D

Table 3. Ancient DNA Sample Results.

Site (CA-)	Sample Context & Catalog # (Accession #)	Element*	Lab # (JAL-)	Species (Based on Morphology)	DNA Species Assignment
ALA-329	Canid Interment, Pit 60N, 60W (54" West, 21" South, 62" Deep)	Upper left canine	5358	Dog	Dog or Wolf**
MRN-5	Feature 1	Upper left M1	5362	Dog	Dog
SAC-21	Canid Interment, 1-84570 (Ac# 759)	Lower right premolar (P3)	5353	Coyote	No result
SAC-99	Canid Interment, L-17789	Lower left canine	5354	Coyote	No result
SAC-99	Canid Interment, L-17790	Lower right canine	5355	Coyote	No result
SAC-99	Canid Interment, L-17791	Upper (?), canine #2	5356	Coyote	No result
SCL-732	Canid Interment, Feature 110-1	Lower left canine	5357	Wolf	No result
SCL-732	Canid Interment, Feature 111-1 (larger canid)	Lower left canine	5360	Wolf	Dog
SCL-732	Canid Interment, Feature 111-2 (smaller canid)	Lower, right canine	5361	Wolf	No result
SFR-04/H	Unit 24N, 3E, 30-40 cm (cat #1660.06)	Metatarsal #3, left	5359	Undeterminable	Dog
YOL-13	Canid Interment 1, 1-213685 (Ac# 1295)	Lower, right premolar, #3	5363	Coyote	No result
YOL-13	Canid Interment 2, 1-213686 (Ac# 1295)	Lower, left incisor, #3	5364	Coyote	Dog
YOL-13	Canid Interment 3, 1-213687 (Ac# 1295)	Lower, right premolar #2	5365	Coyote	Dog**

* Identified by Tim Carpenter; **result not replicated.

Table 4. Stable Isotope results from canid bone collagen.

Sample ID	Element	Collagen Yield (%)	C:N Ratio	d¹³C	d¹⁵N	d¹³C Apatite	d¹⁸O Apatite	Collagen-Apatite Spacing
SFR-4/H, Unit 24N 3E, 30-40 cm	Metatarsal 3	19.9	3.2	-18.9	9.3	-14.9	-3.3	-4.0
ALA 329 Interment, Pit 60N, 60W	Left Tibia	21.5	3.2	-16.7	9.1	-12.1	-4.4	-4.5
SCL-732 Interment, Feature 110-1	Left Radius midsections	7.4	3.3	-19.8	9.0	-15.1	-5.2	-4.7
SCL-732 Interment, Feature 111-1	Left radius	14.2	3.2	-16.8	8.6	-10.4	-5.5	-6.4
SCL-732 Interment, Feature 111-2	Left Tibia	7.0	3.2	-16.9	8.8	-11.5	-6.3	-5.4

C: carbon, N: nitrogen, d: delta



Figure 1. San Francisco Bay-Delta area showing archaeological sites discussed in text



Figure 2. Canid interment from ALA-329.



Figure 3. Anterior portion of canid interment 111-1 from SCL-732

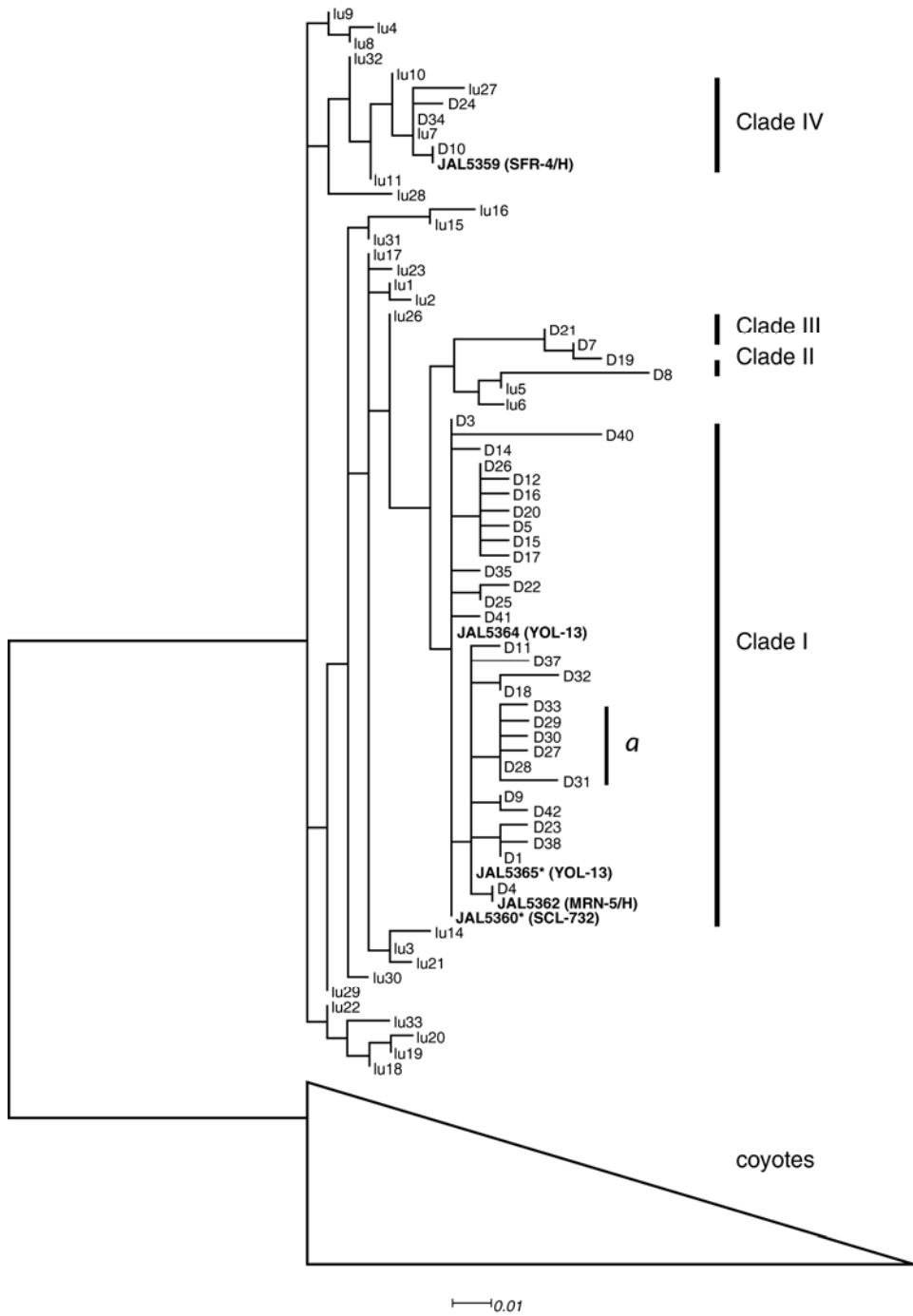

Figure 4. Maximum likelihood phylogeny of canids from California archaeological sites in this study (highlighted in bold) in relation to previously published domestic dogs (prefix D) from the four main clades, gray wolves (prefix lu) and coyotes. Partial sequences are marked with an asterisk.

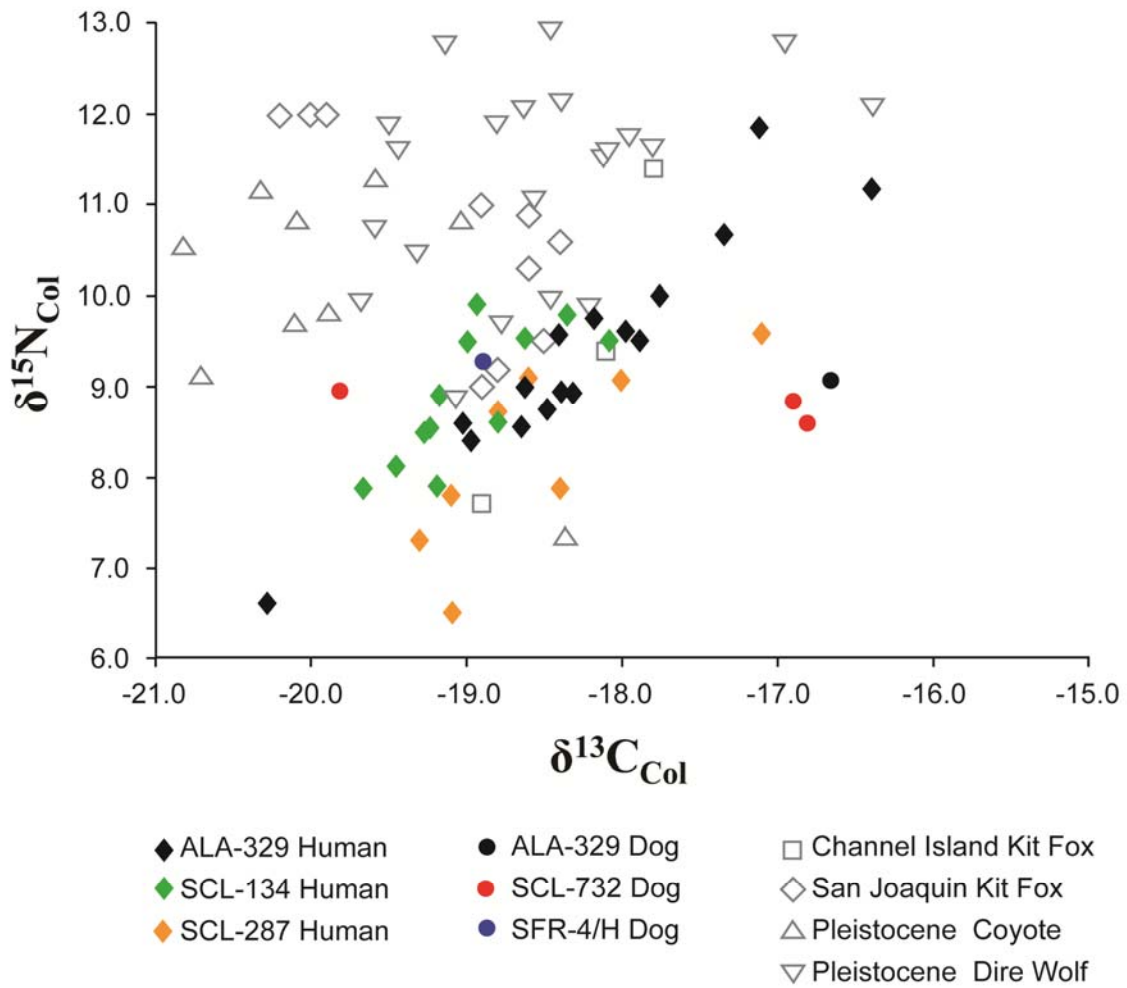

Figure 5. Bivariate plot of nitrogen and carbon collagen stable isotope ratios for dogs in this study in relationship to available Bay area prehistoric Native American human remains and available California area wild canids.

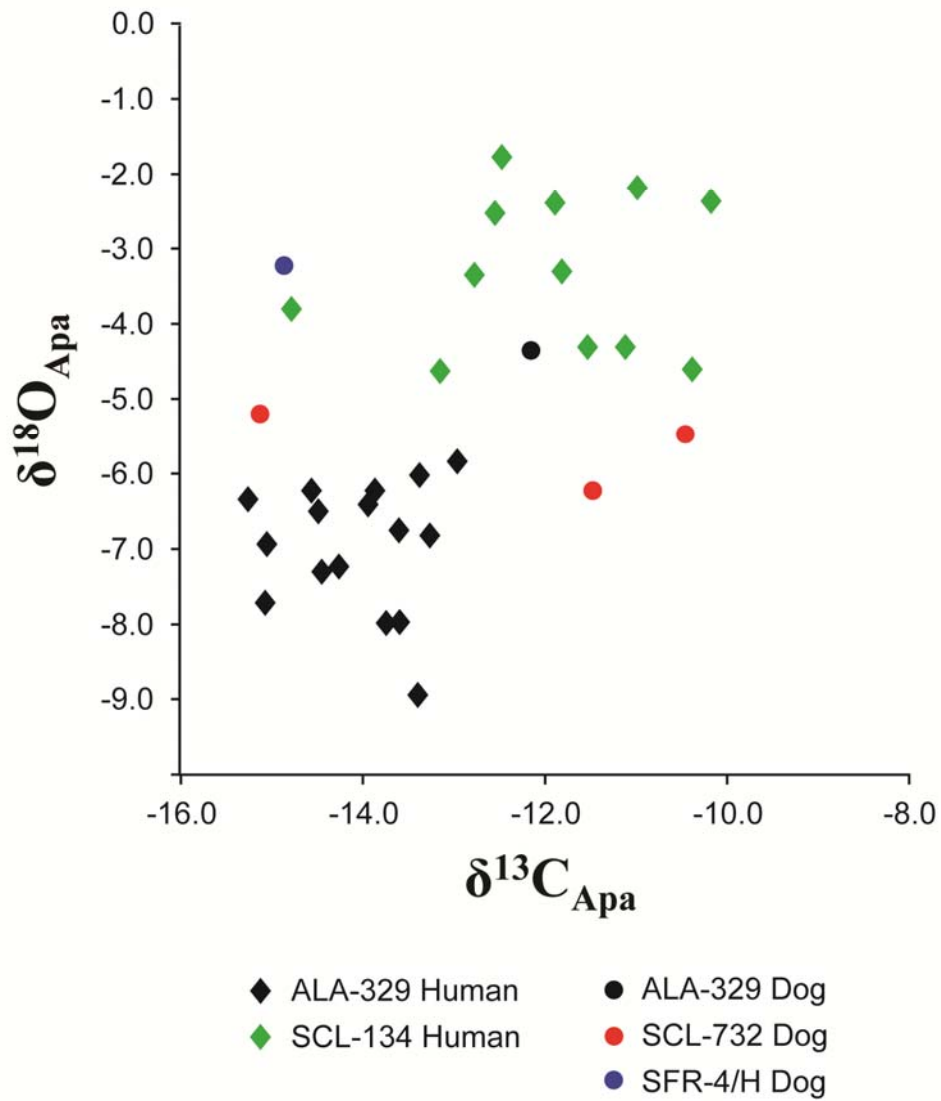

Figure 6. Bivariate plot of oxygen and carbon apatite isotope ratios for dogs in this study in relationship to available Bay area prehistoric Native American human remains.