

Fall 2013

Amphibian Mortality on Roads: A Case Study in Santa Cruz Long-toed Salamander Habitat

Michael Thomas Hobbs
San Jose State University

Follow this and additional works at: https://scholarworks.sjsu.edu/etd_theses

Recommended Citation

Hobbs, Michael Thomas, "Amphibian Mortality on Roads: A Case Study in Santa Cruz Long-toed Salamander Habitat" (2013). *Master's Theses*. 4389.
DOI: <https://doi.org/10.31979/etd.wtyg-2tk4>
https://scholarworks.sjsu.edu/etd_theses/4389

This Thesis is brought to you for free and open access by the Master's Theses and Graduate Research at SJSU ScholarWorks. It has been accepted for inclusion in Master's Theses by an authorized administrator of SJSU ScholarWorks. For more information, please contact scholarworks@sjsu.edu.

AMPHIBIAN MORTALITY ON ROADS:
A CASE STUDY IN SANTA CRUZ LONG-TOED SALAMANDER HABITAT

A Thesis

Presented to

The Faculty of the Department of Environmental Studies

San José State University

In Partial Fulfillment

of the Requirements for the Degree

Master of Science

by

Michael T. Hobbs

December 2013

© 2013

Michael T. Hobbs

ALL RIGHTS RESERVED

The Designated Thesis Committee Approves the Thesis Titled

AMPHIBIAN MORTALITY ON ROADS:
A CASE STUDY IN SANTA CRUZ LONG-TOED SALAMANDER HABITAT

by

Michael T. Hobbs

APPROVED FOR THE DEPARTMENT OF ENVIRONMENTAL STUDIES

SAN JOSÉ STATE UNIVERSITY

December 2013

Dr. Lynne Trulio	Department of Environmental Studies
Dr. Rachel O'Malley	Department of Environmental Studies
Dr. Nina D'Amore	Elkhorn Slough National Estuarine Research Reserve

ABSTRACT

AMPHIBIAN MORTALITY ON ROADS: A CASE STUDY IN SANTA CRUZ LONG-TOED SALAMANDER HABITAT

by Michael T. Hobbs

Amphibian populations have been declining at higher rates than bird and mammal populations. Agriculture, urbanization, including roads, and resource extraction continue to put pressure on all species. Roads in particular, are major sources of mortality. The Santa Cruz long-toed salamander (*Ambystoma macrodactylum croceum*), one of the most critically endangered species in the US, is one amphibian that is declining as a result of anthropogenic impacts, especially habitat loss and fragmentation due to urban development. Migration across roads puts these salamanders at risk from road-related death. This thesis quantified the rate of road mortality to these salamanders and other common amphibians during two *A. m. croceum* breeding-migration seasons in 2011-13 in a portion of the subspecies' range. Vehicular traffic was a major source of mortality to the salamander. Through traffic doubled the overall vehicle load on roads where the *A. m. croceum* migrated to and from breeding ponds. The Pacific chorus frog was also killed on the roads. This common species can be used as an indicator of road mortality risk for rarer amphibians. This study indicated that measures to reduce road mortality to the Santa Cruz long-toed salamander could include restricting vehicular traffic on roads adjacent to salamander ponds by limiting traffic to residential use only during breeding migrations, installing structures to protect *A. m. croceum* while crossing roads, and potentially assisting animals crossing roads at nighttime during the breeding migrations.

ACKNOWLEDGMENTS

I would like to thank my committee members for the time they have spent working directly with me on this thesis. I am amazed at their commitment, energy, and passion to helping all students. Special thanks to Dr. Lynn Trulio for her ability to see what I could not, for coaching me forward when I had stumbled, and for being available when I was in need. Her heart is large and her love for animals true. Special thanks to Dr. Rachel O'Malley for her technical excellence and push for greater knowledge. Special thanks to Dr. Nina D'Amore for her expertise on amphibians and for guiding me toward experts in the field.

This project could not have happened without the aid of some very special interns: Alexis Shields, Steven Anderson, Adam Gomez, Maria Barajas, and Joseph Lovelace. This team trained well, worked well, and was always eager to get outside and find amphibians, having fun. Special thanks goes to my number-one go-to person, Alexis Shields, who assisted both seasons. She possessed much knowledge and her enthusiasm was very contagious.

Special thanks goes to my family and friends. My mom spent many nights watching my son while I worked, my son helped out in the field collecting car data, and my friend Juul spent endless hours designing and testing data capturing equipment, tied to this thesis.

TABLE OF CONTENTS

	Pages
List of Tables	vii
List of Figures	viii
Introduction.....	1
Literature Review.....	4
Threats to Species	4
Amphibians	7
Salamanders	8
<i>A. macrodactylum</i> (mole salamander)	10
<i>A. m. croceum</i> Distribution and Ecology	12
Other Amphibians in <i>A. m. croceum</i> Habitat.....	18
Problem Statement.....	23
Research Objectives.....	24
Research Questions and Hypotheses	24
Methods.....	26
Study System	26
Study Design.....	29
Data Collection	30
Data Analysis	35
Results.....	37
Discussion.....	45
Recommendations.....	50
Literature Cited	52
Appendix 1. Season 1 precipitation/observation data.....	58
Appendix 2. Season 2 precipitation/observation data.....	62
Appendix 3. Field data sheet.....	66
Appendix 4. DOR index card.....	67
Appendix 5. Car counter	68
Appendix 6. Manual car tally sheet	75
Appendix 7. Aggregated Salamander Passage Track (ASPT) TM	76

LIST OF TABLES

Table 1.—Valencia Lagoon SCLTS population estimates.	17
Table 2.—Seascape Pond #3 SCLTS population estimates.....	18
Table 3.—Amphibians found in SCLTS habitat.....	22
Table 4.—Number of nights and observation events per location.....	30
Table 5.—Estimated number of SCLTS likely killed.....	45

LIST OF FIGURES

Figure 1.	<i>Ambystoma macrodactylum croceum</i>	11
Figure 2.	Distribution map of <i>Ambystoma macrodactylum croceum</i>	13
Figure 3.	<i>Ensatina eschscholtzii xanthoptica</i>	20
Figure 4.	<i>Pseudacris regilla</i>	21
Figure 5.	Study sites.....	27
Figure 6.	Car counter.	33
Figure 7.	Car counter circuit board and water resistant housing.	34
Figure 8.	Total species found over two winter seasons (2011-2013).	38
Figure 9.	Species abundance by site.	39
Figure 10.	Number of Pacific chorus frogs associated with precipitation.....	40
Figure 11.	Average number of vehicles/hour at three sites.	41
Figure 12.	Average number of total vehicles/hour	42
Figure 13.	Average number of residential and through vehicles/hour.....	43
Figure 14.	Comparison of <i>Pseudacris regilla</i> mortality.	44
Figure 15.	Sound signature of passing cars.	68
Figure 16.	Printed circuit board assembly.	69
Figure 17.	Car counter microprocessor.....	70
Figure 18.	Power supply schematic.	71
Figure 19.	Operational Amplifier schematic.	72
Figure 20.	System interface.	73
Figure 21.	ASPT single track dimensions.....	76
Figure 22.	ASPT single run illustrated across road.	77
Figure 23.	Integration into road.	77
Figure 24.	ASPT System across road.	78

INTRODUCTION

Scientists contend that we are at the forefront of Earth's sixth mass extinction (Wake and Vredenburg, 2008). Previous mass extinctions, extending as far back as 439 million years, were triggered by colossal natural events such as widespread glaciations, bolide impacts, flood volcanism, seafloor spreading, and a giant asteroid impact. In contrast to these natural causes, today's sixth mass extinction is being driven by intense human pressures such as human population growth, overuse of resources, pollution, habitat conversion, climate change, invasive species, and emergent diseases (Wake and Vredenburg, 2008).

At the First World Congress of Herpetology in 1989, scientists "became concerned about widespread amphibian population declines . . ." (Stuart et al., 2004:1783). As of 2008, a third or more of the world's 6300 identified amphibian species were threatened with extinction (Wake and Vredenburg, 2008). The International Union for Conservation of Nature (IUCN) Red List in 2013 evaluated 52,667 animal species; of these, 11,092 are threatened with extinction and 741 have gone extinct. Amphibians are among the groups most affected, with 1948 threatened with extinction and 36 extinctions. Of the three orders of amphibians, frogs (order Anura), salamanders (order Caudata) and caecilians (order Gymnophiona), salamanders are least familiar in North America, attributed by their "secretive nature and nocturnal habits" (Petranka, 1998:1). Salamanders are valuable for investigating "conceptual and theoretical problems in evolution, ecology, animal behavior, physiology, genetics, and cell biology"

(Petranka, 1998:2). Medical research has assessed salamander limb regeneration, tissue regeneration, genetic disorders, and skin secretions of therapeutic values (Petranka, 1998). Amphibians have also been harbingers of global environmental degradation (Hayes, 2004).

The Santa Cruz long-toed salamander (*Ambystoma macrodactylum croceum*) is a federally and state-listed endangered sub-species of the long-toed salamander (*Ambystoma macrodactylum*), and it is one of the most endangered animals in the United States (USDOJ, 1978). *A. m. croceum* lives approximately 241 km SW of the nearest related subspecies, *A. m. sigillatum* (Russell and Anderson, 1956). Scientists speculate that the Great Central Valley of California created a barrier towards the end of the Pleistocene ice age, which separated these populations (Russell and Anderson, 1956; USDOJ, 1978). As early as the first European occupation, human activities began to fragment *A. m. croceum* populations into smaller and more confined habitat areas, reducing their ability to migrate and inter-breed.

Today, roads are major barriers that sub-divide habitats, isolate animal populations, and kill or maim individual animals (Hels and Buchwald, 2001; Foreman et al., 2003; Mazerolle et al., 2005; Glista et al., 2009). Systematic estimates of road mortalities in the U.S. and other parts of the world are rare; however many rough estimates have been pieced together. For example, Forman et al. (2003) estimated that 720,000 to 1.5 million deer were killed annually on U. S. roads, 205 painted turtles were killed on Route 93 in Montana during a four month period, and an estimated 5.5 million frogs and reptiles were killed annually on Australian roadways. According to Lalo

(1987), nearly 1 million vertebrates are killed on roads in the United States daily. Roads in other countries, such as Britain, with more road land area than major river land area, constitute the most significant barrier to wildlife movement, and the long term effects on animal populations can be severe (Beebee, 2012).

The Santa Cruz long-toed salamander was first listed as endangered by the United States Fish and Wildlife Service (USFWS) in 1967 (USDOJ, 1967). The Federal Endangered Species Act (ESA) of 1973 protects all federally listed “endangered” or “threatened” species and makes it unlawful for anyone to “take” any such species. “Take” includes harass, harm, pursue, hunt, shoot, wound, kill, trap, capture, collect or to attempt to engage in any such conduct (USFWS, 2009a). *A. m. croceum* was also listed endangered by California in 1971 (CDFW, 2013). The California Endangered Species Act (CESA) requires that all native species and their habitats be protected or preserved. While mitigation is required for projects that will impact this species, existing roads present an ongoing threat. Roads continue to cause harm to this species long after they are built. When animals migrate during the breeding season, from upland habitat to ponds and back, they risk being killed or maimed. Since being listed, little information has been available on the numbers of *A. m. croceum* that are killed by roads adjacent to their habitat. This study assessed *A. m. croceum* numbers killed on roads, as well as the numbers of other amphibians in *A. m. croceum* habitat. The results of this study provide information to wildlife managers on population impacts and for protecting *A. m. croceum* from road mortality.

LITERATURE REVIEW

Threats to Species

As human populations increase, the demand for natural resources and new infrastructure increases. Since the industrial revolution, areas of land for agriculture, building infrastructure, and other human endeavors have grown. Many animal species and their habitats have become victims of habitat loss, fragmentation, and degradation. Loss of habitat is the most common cause of species endangerment (Czech et al., 2000). Scientists agree that the human population increase in the last two centuries is correlated with global declines of animal biodiversity (Petranka, 1998). The greatest impacts to species have come from wetland draining, agriculture, water pollution, deforestation, urbanization, climate change, pathogens, and non-native predator introductions (Dahl, 1990; Rubbo and Kiesecker, 2004; Stuart et al., 2004; McCallum, 2007; Wake and Vredenburg, 2008). These impacts reduce, fragment, and degrade species' habitats. Environmental alterations are responsible for declines in animal biodiversity (Petranka, 1998). Changes to habitat have led to species extinction and endangerment (Scott et al., 2001). As of 2009, the number of endangered species listed in the United States was 1011 (USFWS, 2009b), with many others awaiting listing.

Habitat fragmentation is a primary cause of animal extinctions (Wilcox and Murphy, 1985). Habitat fragmentation, as occurs with roads, separates habitat patches and populations, which can isolate species within metapopulations. Metapopulations are

populations that are fragmented into many sub-populations that exchange inhabitants (Allaby, 2010). As humans build and expand infrastructures, habitats are fragmented. As a result, metapopulation inhabitants are separated from other metapopulation inhabitants due to loss of dispersal corridors and habitat loss (Marsh and Trenham, 2001).

A key factor in amphibian declines is the loss of wetland habitats. Wetland habitats support aquatic communities and their destruction wipes out populations. In the United States (lower 48), an estimated 53% of wetlands have been lost. California has the highest percentage loss of wetlands in the US, at 91%, primarily due to agriculture and urban development (Dahl, 1990). Alterations to wetlands are of serious concern because they are easily modified by urban development. Wetlands are surrounded by terrestrial habitat which animals, such as amphibians, use. There have been correlations between surrounding forested habitat loss and amphibian reductions (Rubbo and Kiesecker, 2004).

Urbanization is a pervasive threat to many species (Bury and Ruth, 1972; Czech et al., 2000; McKinney, 2002). As human populations continue to increase, urban sprawl grows and consumes land. Designing urban areas to grow vertically rather than horizontally can reduce the amount of consumed land, however urbanization in itself still depletes natural resources, harming natural communities (Czech et al., 2000). With urban sprawl has come roads. From dirt roads, to multilane highways, to railroads, by their very nature roads remove habitat and divide landscapes. In the United States 19% of the land area is ecologically affected by public road systems and associated vehicles (Forman, 2000). "Road ecology" looks at ecological flows and their disruptions due to

landscape fragmentation (Shilling, 2007). Roads affect the ecosystem of aquatic and terrestrial communities in several different ways. Trombulak and Frissell (2000:19) identify seven kinds of effects that roads have on these animal communities: “. . . (1) increased mortality from road construction, (2) increased mortality from collision with vehicles, (3) modification of animal behavior, (4) alteration of the physical environment, (5) alteration of the chemical environment, (6) spread of exotic species, (7) increased alteration and use of habitats by humans.”

Scientists agree that amphibian populations throughout the world have been declining as a result of alterations to the environment. Ecological flows around road systems are critical for nature protection (Forman, 2000). Though road mortality has received less of the blame for declines, a considerable amount of research documents road mortality in amphibians (van Gelder, 1973; Fahrig et al., 1995; Trombulak and Frissell, 2000; Hels and Buchwald, 2001). Studies of traffic loads and movement rates have indicated that vehicular traffic kills amphibians and has an effect on population sizes (Carr and Fahrig, 2001). Amphibian dispersal to breeding ponds may directly increase road exposure (Eigenbrod et al., 2008). For smaller populations, road impacts significantly increase the risk of extinction (Carr and Fahrig, 2001). Aquatic-breeding amphibians are more vulnerable to road mortality than most other species due to breeding migrations to and from preferred terrestrial habitat locations (Hels and Buchwald, 2001).

Scientists working at the Information Center for the Environment (ICE) at the University of California at Davis have built an online system where observers can input data from roadkill discovered in the field. The database, called the California Roadkill

Observation System (CROS) can summarize categories of species, observation dates, and generate roadkill maps. Their data allow researchers to conduct statistical modeling to predict roadkill hotspots, measure elements of contributing factors, quantify impacts, and estimate the benefits of remedial recovery plans. The scientists at ICE have also published a manual that outlines procedures which can assist in identifying wildlife crossing conflicts, making choices for effective avoidance measures, minimizing and possibly compensating for mitigation strategies, and even evaluating the results of such actions (Caltrans, 2009). Roadkill information can be valuable to biologists, environmental planners, city planners, engineers, and the California Department of Transportation (Caltrans, 2009). As more and more data are entered into the system, scientists will have solid quantitative data that can contribute to efforts to reduce road mortality.

Amphibians

In 1989, at the first World Congress of Herpetology (WCH) in Canterbury UK, reports were released that announced world populations of amphibians were decreasing at a greater rate than birds and mammals and that this “. . . began as early as the 1970’s . . .” (Stuart et al., 2004:1783). Amphibians are declining as a result of habitat degradation and fragmentation (Smith and Green, 2005).

Amphibians originated some 360 million years ago (Petranka, 1998). According to Mattison (2011) there are 6640 identified species, of which 5858 are Anura (frogs and

toads), 597 are Caudata (salamanders and newts), and 185 are Gymnophiona (caecilians). External morphological features are used for identification. Frogs have no tail and their limbs are specialized for jumping. Salamanders have unmistakable tails with two sets of limbs of near equal size. Caecilians specialize in burrowing and have bodies that are drawn out with ringed grooves throughout. Legs are missing and they may or may not have a tail (Petranka, 1998).

Salamanders

The loss of salamanders is a loss not only for natural biodiversity, but also for health sciences and environmental sciences. Salamanders are used in health science to study limb and tissue regeneration, for biochemistry and physiology of vision, as well as studying the value of their toxic skin for cancer research (Petranka, 1998). In environmental sciences salamanders are used as indicators of environmental well-being (Petranka, 1998).

According to AmphibiaWeb (2013), there are 10 families of salamanders comprising the 650 species: Ambystomatidae (32), Amphiumidae (3), Cryptobranchidae (3), Dicamptodontidae (4), Hynobiidae (59), Plethodontidae (436), Proteidae (6), Rhyacotritonidae (4), Salamandridae (99), and Sirenidae (4). Within the United States and Canada there are 127 species (Petranka, 1998).

Salamanders are generally nocturnal and secretive in nature, making them one of the least known groups of vertebrates (Petranka, 1998). Salamanders are sensitive to low

humidity and dry environments and their skin must remain moist to survive. For terrestrial salamanders, a mature forest provides shade and dense leaf cover that reduces evaporation, retaining moisture in the ground.

Salamanders prefer habitats that are rich with insects. They are predatory animals that feed primarily on small aquatic and terrestrial invertebrates (Petranka, 1998). Larger salamanders are known to prey on fish, snakes, small mammals, and birds (Petranka, 1998).

The life cycle for many salamanders is biphasic, meaning they undergo metamorphosis. Salamanders exhibit three typical life history patterns in North America. For example, the adult female mole salamander (Family: Ambystomatidae) lays fertilized eggs in ponds and streams where the larvae will hatch and grow. After metamorphosing into juveniles, the salamander estivates in upland habitats only to return to the water in future breeding seasons. The first life history pattern, water/land, describes a salamander born in water and living on land. A second life history pattern, water/water, occurs when terrestrial habitats are not conducive for survival and the species lives in a permanent aquatic habitat. A third life history pattern, land/land, occurs where terrestrial species lay their eggs in hidden sites; under moist decaying logs, moist rock cleavage, or moist underground microhabitats and fully formed young hatch out into terrestrial habitats (Petranka, 1998).

A. *macrodactylum* (*mole salamander*)

Mole salamanders (*Ambystoma*) live in small animal burrows built by mice, voles, gophers and moles (USFWS, 1999). Their life history is a water/land pattern. Larvae of the *Ambystoma* are typically the top predator in ephemeral ponds, feeding primarily on aquatic invertebrates and other amphibians. They can influence the diversity and abundance of aquatic invertebrates as well as some amphibians. Smaller salamanders are preyed upon by fish, snakes, small mammals, and birds (Petranka, 1998).

Ambystoma larvae that utilize ephemeral ponds have elevated growth rates lasting only 2-6 months. This fast growth rate has its advantages and disadvantages. An advantage is that larvae morph into juveniles more quickly and become less dependent on the aquatic environment. The disadvantage is that mortality rates are higher because ephemeral ponds may deplete too soon, desiccating larvae, or producing smaller juveniles at the terrestrial stage. Mortality of larvae in ephemeral ponds is higher than that of larvae in streams. To compensate for the higher mortality rate, the number of eggs produced in ponds is higher than in streams (Petranka, 1998). Juveniles disperse from breeding sites and return when they reach sexual maturity, in one to two years (Petranka, 1998).

Five subspecies of *Ambystoma macrodactylum* (long-toed salamander) inhabit the northern hemisphere of the Americas, and all are located in western United States and Canada (Ferguson, 1961).

The following subspecies of *A. macrodactylum* are described by Ferguson (1961):

A. m. columbianum (Eastern) Dorsal band is wide and uninterrupted. Dorsal color varies from bright yellow to tan and has a metallic appearance over black background. Spots are well-defined on head, snout and eyelids.

A. m. krausei (Northern) Dorsal band is bright yellow at mid-body and becomes darker along the tail. Dorsal stripe is narrow and continuous until the last 2 mm of the tail where it breaks. Each eyelid has well defined spots of pigment.

A. m. macrodactylum (Western) Dorsal banding is very diffused and transitions into ground color. Dorsal color is dark yellow at mid-body and becomes dull along the tail. Ground color at mid-body nears dark quaker drab.

A. m. sigillatum (Southern) Dorsal band is narrow and frequently interrupted. Dorsal color is bright yellow. Fine spots of same pigment on the head.

A. m. croceum (Santa Cruz) Dorsal band is dull orange to orange over black ground color (Fig. 1). Near continuous strip along crest of tail. Tiny dots of pigmentation on head. Is disjunct from remaining species.



FIG. 1.—*Ambystoma macrodactylum croceum*. Photo by Michael Hobbs 11/16/2012.

The Santa Cruz long-toed salamander (*A. m. croceum*) is an endangered species of mole salamander that lives in two California counties, Santa Cruz and Monterey (USDOI, 1978). The first sighting of *A. m. croceum* occurred in 1954 at Valencia Lagoon in Rio del Mar, Santa Cruz (Russell and Anderson, 1956). Since then the species has been discovered in multiple ponds as far south as Elkhorn Slough. Currently, 24 ponds have been identified as inhabited by *A. m. croceum* (USFWS, 2009a).

A. m. croceum is a relic form of the species and is separated from the other known 4 subspecies of *A. macrodactylum* by 241 km (USDOI, 1978). It is believed that *A. m. croceum* might have been separated from the other subspecies after the late Pleistocene ice age, by the California Central Valley which now separates *A. m. croceum* from the nearest subspecies *A. m. sigillatum*, found in the Sierra Nevada mountain range (Anderson, 1966).

A. m. croceum Distribution and Ecology

A. m. croceum is isolated from its conspecifics by several hundred kilometers in Central California and is currently distributed only across a very small region along the Pacific coast of California in southern Santa Cruz County and northern Monterey County (Fig. 2).

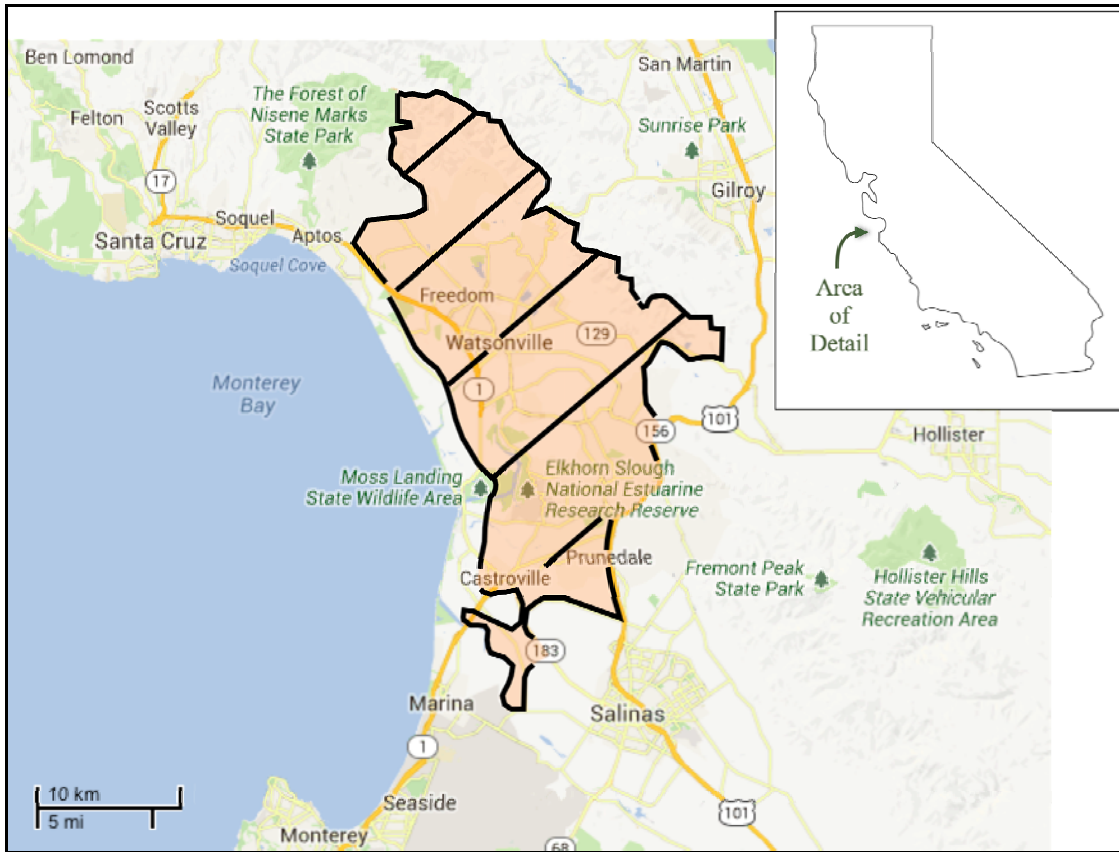

FIG. 2.—Distribution map of *Ambystoma macrodactylum croceum*. Southern Santa Cruz County and northern Monterey County. Beige color represents range (AmphibiaWeb 2013).

The geographical zone of this area is the northern temperate zone. This area does not experience harsh freezing weather or extremely hot and wet seasons as the climate is influenced by the Pacific Ocean. California has a Mediterranean climate, dry in the summer and wet in the winter. Along both the Santa Cruz and Monterey coast, fog engulfs much of the area during the summer giving the region milder temperatures than occur inland. Summer average temperature in Santa Cruz is 17.0°C. Winter average temperature in Santa Cruz is 10.2°C with an annual precipitation mean of 77.8 cm per year. Maximum precipitation in Santa Cruz occurs in January (WRCC, 2006). This

moderate climate is very conducive to the survival of *A. m. croceum* since it is a burrowing amphibian and cannot tolerate extremely dry habitats.

A. m. croceum spends the majority of its life in upland habitats where it lives through summer and fall during the non-breeding season while seeking refuge in root systems, small animal burrows, under rocks, bark and similar areas that are moist (Anderson, 1966). The terrestrial habitat, in the upper elevation, is predominantly made up of coast live oaks (*Quercus agrifolia*), Monterey pine (*Pinus radiata*), coyote brush (*Baccharis pilularis*), hazel shrub (*Corylus rostrata*), coffeeberry (*Rhamnus californica*), flowering currant (*Ribes sanguineum*), blue blossom (*Ceanothus thyrsiflorus*), and occasionally thin distributions of pacific madrone (*Arbutus menziesii*). The terrestrial habitat, in lower elevation, typically consists of dense pacific blackberry tangles (*Rubus*), poison oak clumps (*Rhus diversiloba*) with western sword fern clumps (*Polystichum munitum*) and sparse amounts of bracken fern (*Pteridium aquilinum*) (Russell and Anderson, 1956). Non-native plants are common in the area including blue gum eucalyptus trees (*Eucalyptus globulus*), pampas grass (*Cortaderia selloana*), and Andean pampas grass (*Cortaderia jubata*), which reduce the cover of native vegetation and thus the availability of root systems where *A. m. croceum* prefers to live through the summer and fall (Gordon 1996, USFWS 2009a). Non-native plants also reduce the biomass of invertebrates that the salamanders seek when foraging (USFWS, 2009a).

The most important environmental factor that governs *A. m. croceum* breeding migrations is rainfall (Anderson, 1966). Rainfall determines the timing of inbound and outbound migrations to breeding ponds, breeding activities, and juvenile growth rates

(Anderson, 1966). Migrations only occur on rainy nights (Anderson, 1966; Allaback and Laabs, 2003). With the first winter rains in November and December adults migrate en masse from their upland habitat to ponds for breeding (Reed, 1978). Breeding cannot commence until ponds fill and as such, adults do not emerge until the ground has saturated. Records show that when seasonal rainfall exceeds 10.7 cm (4.2”) adults are triggered to begin migrating, with continued rainfall needed to sustain the migration (Anderson, 1966). The breeding period for *A. m. croceum* occurs in January and February (Anderson, 1966). When breeding stops, adult salamanders return to their upland habitat in random fashion, females first (Ruth, 1988). Juveniles disperse from the ponds in late fall with the first rains (Ruth, 1988). Along their journey both adults and juveniles are faced with challenges, especially predators and obstacles.

A. m. croceum have only been identified breeding in 24 ponds: 17 in southern Santa Cruz County and 7 in northern Monterey County (USFWS, 2009a). Many of these ponds are seasonal while others are permanent. Ephemeral ponds are considered high quality habitat for *A. m. croceum* since they will not sustain predatory fish, crustaceans, and aggressive insects. Riparian vegetation around ponds typically includes arroyo willows (*Salix lasiolepis*), cattail (*Typha*), and knotweed (*Polygonum*) (Russell and Anderson, 1956).

The 24 *A. m. croceum* breeding ponds and their upland habitats are currently divided into six metapopulations as defined by genetic research and current distributions. There are four metapopulations in Santa Cruz County—Valencia-Seascape, Freedom,

Larkin Valley, Ellicot-Buena Vista—, and two metapopulations in Monterey County—McClusky, and Elkhorn (USFWS, 2009a).

Degradation and fragmentation of *A. m. croceum* habitat areas has been ongoing since before the subspecies was discovered in 1954. Natural separations, such as the Pajaro River and Elkhorn Slough, divided northern and southern populations while man-made fragmentation has occurred due to agricultural operations, urbanization and roads (Rubbo and Kiesecker, 2004; Shilling, 2007; USFWS 2009a). These factors are responsible for habitat degradation as well.

Within many metapopulations, migration paths from upland habitats to breeding ponds are compromised by roadways, both new and old, that block migration or create hazardous conditions. In 1955, construction of California State Highway 1 reduced the size of Valencia Lagoon in Rio del Mar, Santa Cruz, *A. m. croceum* habitat (USFWS, 1999). In 1969, California State Highway 1 was converted to a freeway and virtually eliminated the breeding pond creating a permanent barrier to any migration from half the pond area (USFWS, 1999).

The first population study at Valencia Lagoon occurred over two rainy seasons, 1971-72 and 1972-73 where an estimated 500 adult salamanders were found each year (Ruth, 1974; Table 1). A second, more complete study was conducted the following season (1973-74) where an estimated 1000 adults were found (cited in Reed, 1978). A third study during the 1977-78 rainy season used improved methods, including more systematizing and expansive surveys using the “Peterson Method.” An estimated 2583 migratory adults were found. This population study included the pond located inside the

Caltrans drainage channel (Ruth, 1988). The following rainy season—drought year (1978-79), used the same methods as 1977-78 season, which indicated a population of 1350 (Ruth, 1988). The most recent study, in 2007-08, indicates populations have decreased to 734 ± 149 (Allaback and Laabs, personal communications).

Table 1.—Valencia Lagoon SCLTS population estimates.

Year	Estimates	Study
1971-72	500	(Ruth, 1974)
1972-73	500	(Ruth, 1974)
1973-74	1000	(cited in Reed, 1978)
1977-78	2583	(Ruth, 1988)
1978-79 (drought)	1350	(Ruth, 1988)
2007-08	734 ± 149	(Allaback and Laabs, personal communications)

Reed (1978) conducted road surveys on Bonita Drive across from Valencia Lagoon while conducting a SCLTS population study for USFWS. Reed (1978) expended 338 hours searching for SCLTS on roads where an estimated five percent (4 of 72 known SCLTS individuals) were killed within the neighborhood surrounding Valencia Lagoon. Road survey observations were performed between 1730 h and 0200 h. Roads were walked from three to six hours for each favorable night (Reed, 1978).

Seascope Pond #3 was built in 1999 as part of a Habitat Conservation Plan (HCP) at the Seascope Uplands residential development in Aptos. Population studies indicate

increasing numbers from 2002-03 to 2007-08, with an apparent population drop in 2012-13 (Allaback and Laabs, personal communications; Table 2).

TABLE 2.—Seascape Pond #3 SCLTS population estimates.

Year	Estimate
1999-00	Colonized
2002-03	311 ± 50
2003-04	399 ± 76
2004-05	597 ± 105
2005-06	686 ± 122
2006-07	674 ± 135
2007-08	1242 ± 186
2012-13	387 ± 157

Other Amphibians in A. m. croceum Habitat

Other species of amphibians occur in and around SCLTS habitat and may be subject to road mortality. One such species is *Ensatina eschscholtzii xanthoptica* (yellow-eyed ensatina). “The genus *Ensatina* belongs to the family Plethodontidae” (Stebbins, 1949:377). This family contains the largest number of species and has two distinctive anatomical attributes; they are lungless and possess nasolabial grooves (Stebbins, 1949). Respiration is achieved through capillaries located under thin moist skin. The nasolabial groove runs from the nostril to the edge of their upper lip and is

used to transport waterborne chemicals to the vomeronasal organ aiding chemoreception (Petranka, 1998). The genus *Ensatina* has seven recognized subspecies. They inhabit the northern hemisphere of the Americas and are located in western United States and Canada. The *Ensatina* is best recognized by the predominant constriction at the base of its tail. The species is polymorphic and shows different variations of colors and patterns depending on its geographical location (Petranka, 1998).

Populations of *E. e. xanthoptica* can be found on both sides of the Central Valley, possibly separated during the late Pleistocene ice age (Petranka, 1998). Its upper body surface is dark brownish orange while the sides of the head, abdomen, tail, and eyelids are a brighter salmon orange (Fig. 3). The upper half of the iris is distinct with bright yellow coloration (Stebbins, 1949). Aposematic coloration of the yellow-eyed *ensatina* mimics that of the Pacific newt (*Taricha torosa*), which are highly toxic (Kuchta, 2005). The base of the tail is visibly constricted and designed for caudal autonomy. The tail also possesses hypertrophied poison glands. Both mimicry and caudal autonomy combine to combat predation (Stebbins, 1949).



FIG. 3.—*Ensatina eschscholtzii xanthoptica*. Photo by Michael Hobbs 1/19/2012.

E. e. xanthoptica has a terrestrial life history pattern land/land. Eggs are laid in the spring or early summer with incubation occurring during the dry season. Metamorphosis occurs inside the egg and the animal hatches fully formed appearing during the first rains of fall or winter. Animals of all sizes appear during the first heavy rains of the season to replenish moisture through dermal absorption and to take up feeding (Stebbins, 1949).

The Pacific chorus frog (*Pseudacris regilla*), a species of tree frog, is another common local species in SCLTS habitat. According to Mattison (2011) there are 49 families of frogs and toads worldwide consisting of 5858 species. The largest family is Hylidae with approximately 870 species (Faivovich et al., 2005). Hylidae commonly have adhesive toe discs containing a piece of cartilage that offsets their terminal phalanx,

possibly aiding them in climbing (AmphibiaWeb, 2013). *Pseudacris regilla*, formerly known as *Hyla regilla*, belongs to the subfamily Hylinae (Faivovich et al., 2005) and ranges from California to Alaska (AmphibiaWeb, 2013). The Pacific chorus frog is a small frog reaching near 5 cm as an adult. They have a prominent stripe (mask) on either side of their head that runs from the nostril, through the eyes, reaching their front shoulders (Fig. 4). Colors range from green to brown and can lighten and darken. The life pattern of this species is water/land. The breeding season is from November to July. Pacific chorus frogs are ground dwellers, preferring cool moist vegetation and low shrubs (Stebbins, 2003).



FIG. 4.—*Pseudacris regilla*. Photo by Michael Hobbs 3/13/2012.

Studies, as well as personal communications, via research biologist, suggest the following amphibians may be found in SCLTS habitat (Table 3).

TABLE 3.—Amphibians found in SCLTS habitat.

Common Name	Scientific name	Study
Arboreal salamander	<i>Aneides lugubris</i>	(Russell and Anderson, 1956)
Bull frog	<i>Rana catesbiana</i>	(Reed, 1978)
California newt	<i>Taricha torosa</i>	(Reed, 1978)
California red-legged frog	<i>Rana draytonii</i>	(Russell and Anderson, 1956)
California slender salamander	<i>Batrachoseps attenuatus</i>	(Russell and Anderson, 1956)
California tiger salamander	<i>Ambystoma californiense</i>	(Ruth, 1988)
California toad	<i>Anaxyrus boreas halophilus</i>	(Reed, 1978)
Pacific chorus frog	<i>Pseudacris regilla</i>	(Russell and Anderson, 1956)
Rough-skinned newt	<i>Taricha granulosa</i>	(D. Laabs, personal communications)
Santa Cruz black salamander	<i>Aneides flavipunctatus niger</i>	(D. Laabs, personal communications)
Santa Cruz long-toed salamander	<i>Ambystoma macrodactylum croceum</i>	(Russell and Anderson, 1956)
Yellow-eyed ensatina salamander	<i>Ensatina eschscholtzii xanthoptica</i>	(Russell and Anderson, 1956)

PROBLEM STATEMENT

Human populations in Santa Cruz County increased 39% from 1980 to 2010 (U.S. Census Bureau, 1995; U.S. Census Bureau, 2010). With increased population comes increased traffic. Detailed traffic counts adjacent to each *A. m. croceum* site have not been documented; however, commuters in the overall Santa Cruz County have increased 43% from 1980 to 2000 (SCCRTC, 2000). Average daily traffic on Bonita Drive, south of Freedom Boulevard fluctuated between 1329 and 2007 cars/day between 1997 and 2007; However, cars/day on Rio Del Mar Boulevard, south of Club House Drive increased from 8544 to 21,334 cars/day from 1991 to 2008 (SCCRTC, 2011).

Vehicular traffic is responsible for the death of an estimated 1 million animals in the United States daily (Lalo, 1987). For endangered species, road mortality could be a significant factor in species declines. The Santa Cruz long-toed salamander is “among the rarest and most critically endangered amphibian in the United States” (USDOI, 1978:26759). Fewer than 10,000 of these animals were believed to be in existence as of 1978 (USDOI, 1978), all of which are contained in habitats surrounded by roads. Reed (1978) estimated that 5% of *A. m. croceum* were killed on roads within the neighborhood surrounding Valencia Lagoon. Three decades later, USFWS and research biologists continue to state that road mortality remains one of several factors that threaten *A. m. croceum* (Allaback and Laabs, 2003; USFWS, 2009a). In 1999, road tunnels were installed across a known *A. m. croceum* migration corridor in Seascape Uplands to mitigate residential development. Testing for safe passage was conducted in 2002 with

disappointing results, as there was only 9% passage (Allaback and Laabs, 2003). Data quantifying the impact of roads on *A. m. croceum* populations, however, remain inadequate.

RESEARCH OBJECTIVE

The objective of this research is to quantify road mortality to *A. m. croceum* and other amphibians during SCLTS breeding migrations at 3 known and potential SCLTS breeding ponds.

To address this objective, I answered the following research questions and hypotheses:

RESEARCH QUESTIONS AND HYPOTHESES

Research Questions

- RQ₁ Across all three ponds, what proportion of each species of amphibians found on the adjacent road were dead (DOR)?
- RQ₂ Do different amphibians species have different patterns of abundance on roads across the three sites?
- RQ₃ How does precipitation affect amphibian abundance on these roads?
- RQ₄ How do traffic levels differ among sites and throughout the evening?

- RQ₅ Does amphibian mortality reflect traffic differences among sites?
- RQ₆ What was the total number of migrating *A. m. croceum* killed throughout the two breeding seasons (2011-13) on these roads?

Hypotheses

- H₁ Abundance of amphibian species do not differ among ponds.
- H₂ Increased precipitation will cause increases in amphibian abundance.
- H₃ Total vehicle traffic rates will be higher during commute hours.
- H₄ Through traffic rates will not vary among sites.
- H₅ Residential traffic rates will vary among sites.

METHODS

Study System

Data for this study were collected in Santa Cruz County within the Valencia-Seascape metapopulation complex (USFWS, 2009a). Road transects of Bonita Drive adjacent to breeding ponds that separate ponds and upland habitat at two known breeding ponds (Seascape #3, and Valencia Lagoon) and one potential pond (Caltrans drainage channel/pond) were observed (Fig. 5).

Sizes of these seasonal ponds vary, depending on precipitation totals and the frequency and length of the rainy season. Seascape Pond #3 is approximately 0.06 ha and 16 m from the road. Caltrans drainage channel/pond is approximately 0.08 ha and 17 m from the road. Valencia Lagoon is approximately 0.26 ha and 29 m from the road.

The three ponds are located within 2092 m of each other with Valencia Lagoon northeast of Caltrans drainage channel/pond and Seascape Pond #3. Valencia Lagoon and Caltrans are in close proximity of each other with less than 400 m separating them. Seascape is furthest from both Valencia and Caltrans by approximately 1770 m, measured from Caltrans.

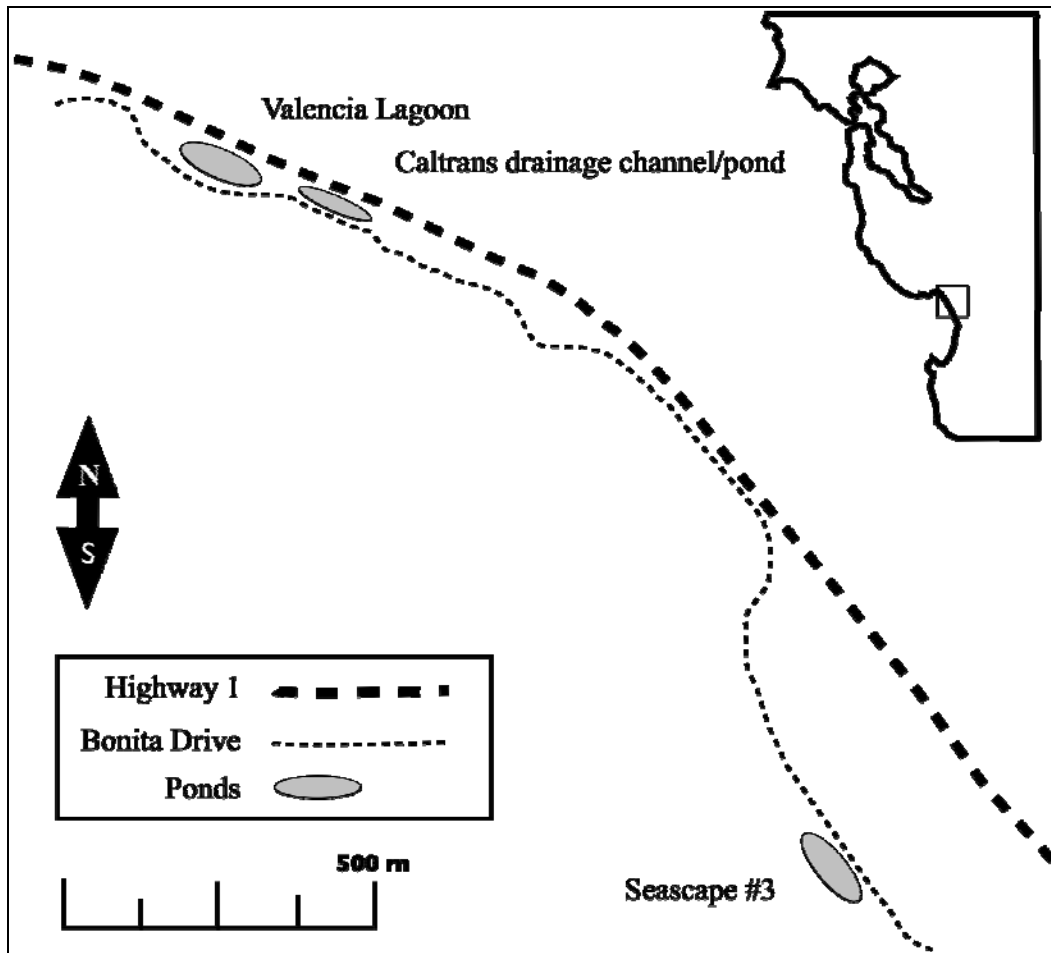

FIG. 5.—Study sites; Valencia Lagoon, Caltrans drainage channel/pond, and Seascape Pond #3.

The length of Bonita Drive is approximately 3.2 km. Its southern most access terminates at San Andreas Road (Southern exit off Highway 1) and its northern most access ends at Club House Drive, off of Rio Del Mar Boulevard. The southern termination of Freedom Boulevard bisects into Bonita Drive approximately 1.4 km from Club House Drive, providing access to Highway 1.

At Seascape Pond #3, the land NE of Bonita Drive, opposite the pond, is designated in the general plan land use as rural-residential and is zoned as Residential

Agriculture (RA). The pond side of Bonita Drive located SW is designated in the general plan land use as urban low residential and is zoned as Special Use – Salamander Protection (SU-SP). A permanent drift fence encircles the pond with multiple gaps to allow SCLTS juveniles to emigrate prior to the start of annual population studies. The road is relatively straight. There was a single gradual cline of about 24 m measured from 168 meters above sea level (m.a.s.l.) at the SE end of the road and 192 m.a.s.l. at the NW end of the road. There was one T-intersection on the east side leading to a dead end residential street: Vista Grande Drive, accessing 10 homes in a gated community. The posted speed limit in this area of Bonita Drive is 30 mph.

At the Caltrans drainage channel/pond the land northeast of Bonita Drive in the channel/pond area is designated in the general plan land use as public facility and is zoned as Public Facility (PF). A permanent salamander barrier is in place between Bonita Drive and the channel/pond preventing salamanders from entering the waterway and obtaining access to Highway 1. The residential side located SW of Bonita Drive is designated in the general plan land use as urban low residential and is zoned as single family Residential – Salamander Protected (R-1-10-SP). This area also has a single large parcel at the northwest end zoned as Parks Recreation and open space – Salamander Protected (PR-SP). This road had two curves at its mid point. Both SE and NW ends of road were 130 m.a.s.l., with multiple clines ranging down to 126 m.a.s.l.. There were three T-intersections on the west side of Bonita Drive leading to three dead end residential streets: Bonita Drive (cul-de-sac) accessing four homes, Rincon Drive accessing 10 homes, and Encino Drive accessing 70 homes. Bonita Drive is posted with

a California Department of Transportation warning sign (code W53) “Not A Through Street (road)” north of the Freedom Boulevard bisect. The posted speed limit in this area is 15 mph.

At Valencia Lagoon the land on the lagoon side northeast of Bonita Drive is designated in the general plan land use as resource conservation and is zoned as PR-SP. The salamander barrier located at the Caltrans site extends through this area and runs between the lagoon and Highway 1, restricting salamander access to Highway 1. The residential side, which is southwest of Bonita Drive, is designated in the general plan land use as urban low residential and is zoned as R-1-10-SP. This southwest area also includes eight parcels designated in the general plan land use as resource conservation and is zoned as PR-SP. The majority of the road formed a single large curve with two additional small curves. Both the SE and NW ends of the road were 130 m.a.s.l., with multiple clines ranging down to 122 m.a.s.l. The posted speed limit in this area is 15 mph.

Study Design

This study was conducted during two rainy seasons from 2011-2013. Observations were conducted during each observation event, which consisted of traversing a single transect one direction and back, each site exclusively. Observations were between 1900 h and 2200 h, with one date 16 November 2012 starting at 1800 h and

one date 23 December 2012 ending at 0230 h, due to heavy rains and large frog presence, respectively.

Season 1 observation events started with the first rain on 3 November 2011 and ended 13 March 2012 (Appendix 1). Accumulated rain totals for Season 1 exceeded 10.7 cm (4.2”) on 20 January 2012. Rain was often uneven and absent during a 5 week period from 16 December 2011 to 18 January 2012.

Season 2 observation events started after the occurrence of several trace rains (16 November, 2012) and ended December 25, 2012 (Appendix 2). Accumulated rain totals for Season 2 exceeded 10.7 cm (4.2”) on 30 November 2012. Rain was more abundant and frequent in November and December months of Season 2 than Season 1. In total there were 64 observation events in 19 nights: 30 events during 8 nights in Season 1 and 34 events during 11 nights in Season 2 (Table 6).

Table 4.—Number of nights and observation events per location.

	Nights	Seascape events	Caltrans events	Valencia events	Total events
Season 1	8	12	10	8	30
Season 2	11	11	11	12	34
Total	19	23	21	20	64

Data Collection

Amphibian counts.—Belt transects 382 m in length were surveyed along Bonita Drive adjacent to each pond. Width of the belt transect at the Seascape site encompassed the width of the road at 8 m. Width of the belt transect at the Caltrans site encompassed

the width of the road at 4 m. The belt transect at the Valencia site began at the 382 meter termination of the Caltrans site. These two transects linked near Encino Drive. Width of the belt at the Valencia site encompassed the width of the road at 4 m wide.

I sprayed white chalk lines, 46 cm in length, on adjacent sides of the road to be used as reference points for measurements and then assigned alphabet letters. As animals were found, their locations were measured to the nearest line. Areas between alpha lettering were referred to as sections (A-B, B-C, etc.). Alpha-lettering prevented numerical errors when documenting measurements. Letters were kept in sequence, starting at the SE end of each transect continuing NW, terminating at 382 m. The markings allowed observers to keep their eyes on the road in the dark. Sections ranged from 13 m to 52 m as referenced telephone poles and government signs varied. Distances were measured using a surveyor's wheel.

Each transect was searched for animals during each observation event. As animals were discovered, reflective washers were placed next to them. Species were identified, assessed whether alive on road (AOR) or dead on road (DOR), and immediately documented in the field data sheet (Appendix 3). All wounded animals were deemed DOR. Reflective washers were recovered on the return walk along the road. If additional animals were found on the return walk, they were measured immediately. Several rainy nights produced great numbers of Pacific chorus frogs, making the use of washers ineffective. For such events, measurements were made during the first pass along the transect, and frogs were not counted on the return walk.

Each SCLTS found DOR was logged in the field data sheet as well as an independent DOR index card where date, time, GPS location, and heading were entered (Appendix 4). A picture was then taken of the DOR index card next to the deceased animal. No animals were touched. All information was entered into the California Roadkill Observation System (CROS, 2011).

For safety purposes, two-member teams traversed the road each observation night. Teams ranged from two to four, dependent on whether training or not. Members wore yellow reflective vests identifying themselves as SJSU research team members. Santa Clara County Sheriff's dispatch was called and notified each night prior to starting.

Precipitation.—Precipitation totals were monitored using the California Irrigation Management Information System (CIMIS) located at www.cimis.water.ca.gov/cimis/welcome.jsp. Daily reports from De Laveaga station 104 were used to calculate rain totals. De Laveaga is located 91 m.a.s.l. and is approximately 13 km from Seascap, 11 km from Caltrans, and 10 km from Valencia.

Vehicle counts.—A stand-alone remote programmable sound detection system (car counter) was used to collect traffic data (vehicles/hour) at Seascap (Fig. 6).



Fig. 6.—Car counter.

Passing cars were recognized and tallied by their sound signature. As cars approached the car counter, sound levels gradually increase, reach a relatively high peak, and then gradually decrease. Time duration and peak level (amplitude) are key to distinguishing a passing car from most other sound signatures such as persons walking, talking, biking, barking dogs, rain, low flying aircraft, and lawnmowers. Most of these, with the exception of rain, did not present themselves during the night time-periods of this study. Components were integrated onto a printed circuit board and encased in a water resistant housing unit for field operations (Fig. 7).

See Appendix (5) for the design of the printed circuit board, with multiple components creating circuits of varying responsibilities.

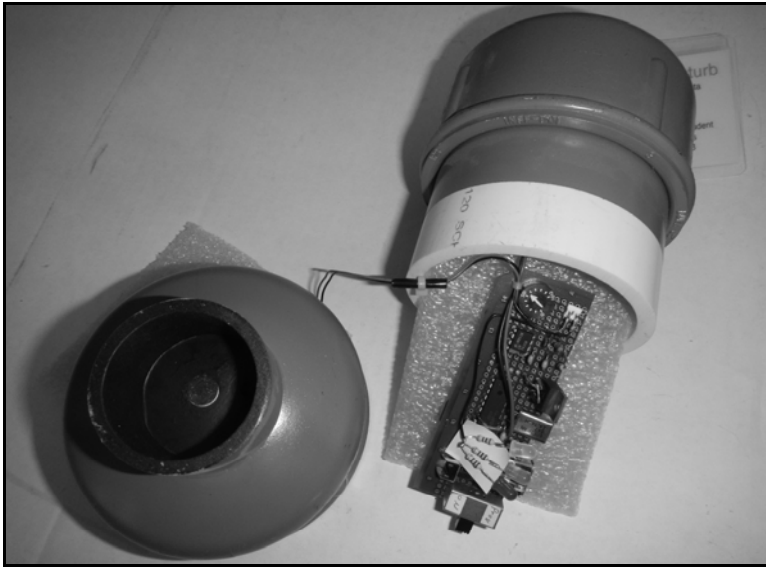

FIG. 7.—Car counter circuit board and water resistant housing.

Vehicle sound signatures at Caltrans and Valencia rendered the car counter ineffective. Differing road characteristics combined with proximity to Highway 1 noise created erratic sound signatures that were undecipherable. Caltrans and Valencia traffic data was collected manually using a tally sheet (Appendix 6). Manual data collection allowed me to classify traffic into three groups: total traffic, through traffic, and residential traffic. Vehicles were tallied at two T-intersections of dead end residential roads; Bonita Drive (cul-de-sac), and Encino Drive. Data were collected in 30-minute intervals for use in data analysis as well as for deciphering residential traffic from through traffic. Data were collected 3 hours/night for 8 nights, 5 weekday nights and 3 weekend nights. Data collections started at 1700 h and lasted until 2000 h and were analyzed as hourly time-periods. Vehicles entering or exiting Bonita Drive (cul-de-sac), Rincon Drive, and Encino Drive were considered residential traffic, vehicles bypassing

these dead end roads were considered through traffic. Residential and through traffic counts were calculated by subtracting incoming and outgoing tallies between Bonita Drive (cul-de-sac) and Encino Drive T-intersections and allotting them appropriately. If vehicles passing through the Bonita Drive (cul-de-sac) intersection equaled vehicles passing through the Encino Drive intersection, they were allotted through traffic. If vehicles entering were less than vehicles exiting, they were counted as residential traffic. Total traffic was the sum of residential traffic and through traffic.

DATA ANALYSIS

Data were analyzed using SPSS Statistics 20.0 (IBM). I performed Levene's test for homogeneity of variance and Shapiro-Wilk's test for normality. Microsoft EXCEL was used for descriptive statistics and charting.

Traffic.—All traffic data (vehicles/hour) were log transformed to meet assumptions for parametric tests and Scheffé's method was used for all post-hoc analyses. Two-way ANOVA was used to test for differences in vehicles/hour for two factors, site (Seascape, Caltrans, Valencia) and time-period (1700 h – 1800 h, 1800 h – 1900 h, 1900 h – 2000 h). A *t*-test was used to assess differences in total vehicles/hour at Caltrans and Valencia. Two-way ANOVA was used to test for differences in vehicles/hour at Caltrans and Valencia for through traffic and residential traffic.

Amphibian.—Chi-square was used to test for differences in the numbers of Santa Cruz long-toed salamander, yellow-eyed ensatina, and Pacific chorus frog found at Seascape, Caltrans, and Valencia. Regression analysis was used to test the relationship between abundance of Pacific chorus frogs (dependent variable) and the amount of precipitation within 24 hours (predictor). Data were insufficient to conduct regression analysis for the other species.

SCLTS total mortality.—Because I only observed a short period of time each night, I estimated how many hours SCLTS were likely to be out each full night for the entire two seasons (2011-13). I estimated the number of SCLTS likely killed during the two winter breeding migration seasons ($n_{\text{DOR-total}}$) with the following formula:

$$\frac{n_{\text{DOR-obs}}}{t_{\text{obs}}} \times t_{\text{total}} = n_{\text{DOR-total}}$$

Where $n_{\text{DOR-obs}}$ is the total number of SCLTS observed DOR during the study period (2011-13), and t_{obs} is the total time (hours) observing SCLTS DOR during same study period. Migration hours, t_{total} , were determined by adding each day of measureable precipitation recorded by CIMIS at De Laveaga station 104 during two winter breeding migration seasons (2011-13) and multiplying this by a referenced number of hours (4 h) searching SCLTS per night, based on similar time spent in studies by Reed (1978) and Allaback and Laabs (2003).

Two calculations were conducted for each site. The first calculation estimated SCLTS likely killed prior to the 10.7 cm threshold of accumulated precipitation during which time adult salamanders are waiting for their migration trigger. This period of time targets the number of juvenile SCLTS emigrating from their old depleted aquatic habitat into their new terrestrial habitat. The second calculation estimated SCLTS likely killed within all days of measurable precipitation (total), which includes both juvenile and adult SCLTS.

Average mean percentage of Pacific chorus frogs found DOR was compared to vehicles/hour at each site to assess frog mortality as a validation metric for SCLTS mortality mitigation progress.

RESULTS

Limitations to this study include rainfall patterns and sample sizes. Seasonal rain during both study periods differed. The accumulation of rain reaching 10.7 cm in Season 1 occurred in mid January, Season 2 occurred in late November. Sample sizes of SCLTS and *Ensatina* in both seasons were small. Results should be interpreted in light of these limitations.

Over the course of two breeding seasons, we collected data for a total of 55 hours. The effort at each site was nearly the same; 20 h of data collected at Seascapes, 18 h at Caltrans, and 17 h at Valencia. We walked a total of 51,952 m collecting data. The

distance walked at Seascape equaled 16,808 m, Caltrans 17,572 m, and Valencia 17,572 m.

During the course of the study, we found five different amphibian species in the SCLTS habitat. The most commonly found to least are Pacific chorus frog ($n = 671$), yellow-eyed ensatina salamander ($n = 31$), Santa Cruz long-toed salamander ($n = 11$), arboreal salamander ($n = 8$), and California slender salamander ($n = 7$; Fig. 8).

Because the California slender salamander and the arboreal salamander were so uncommon, I conducted further analyses on the two most commonly found species, Pacific chorus frog and yellow-eyed ensatina as well as the endangered species Santa Cruz long-toed salamander. Of the 3 species studied, the percentage of DOR was 77% Pacific chorus frogs, 29% yellow-eyed ensatina, and 64% Santa Cruz long-toed salamander.

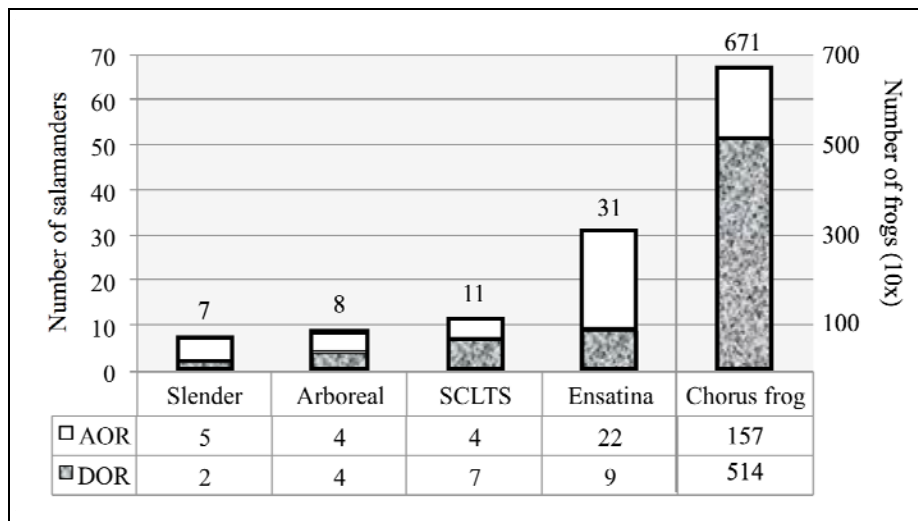

FIG. 8.—Total species found over two winter seasons (2011-2013) across all three sites. Species found alive on road (AOR) have solid white bars while species found dead on road (DOR) have patterned black bars. The scale for Pacific chorus frogs is 10x larger than all other species.

Santa Cruz long-toed salamanders were significantly more abundant at Valencia Lagoon than Seascape and Caltrans ($\chi^2_{(1, n=11)} = 4.46, p = 0.035$), yellow-eyed ensatina were most abundant at Seascape ($\chi^2_{(2, n=31)} = 20.19, p = 0.000$), and Pacific chorus frogs were most abundant at the Caltrans site ($\chi^2_{(2, n=671)} = 203.02, p = 0.000$; Fig. 9).

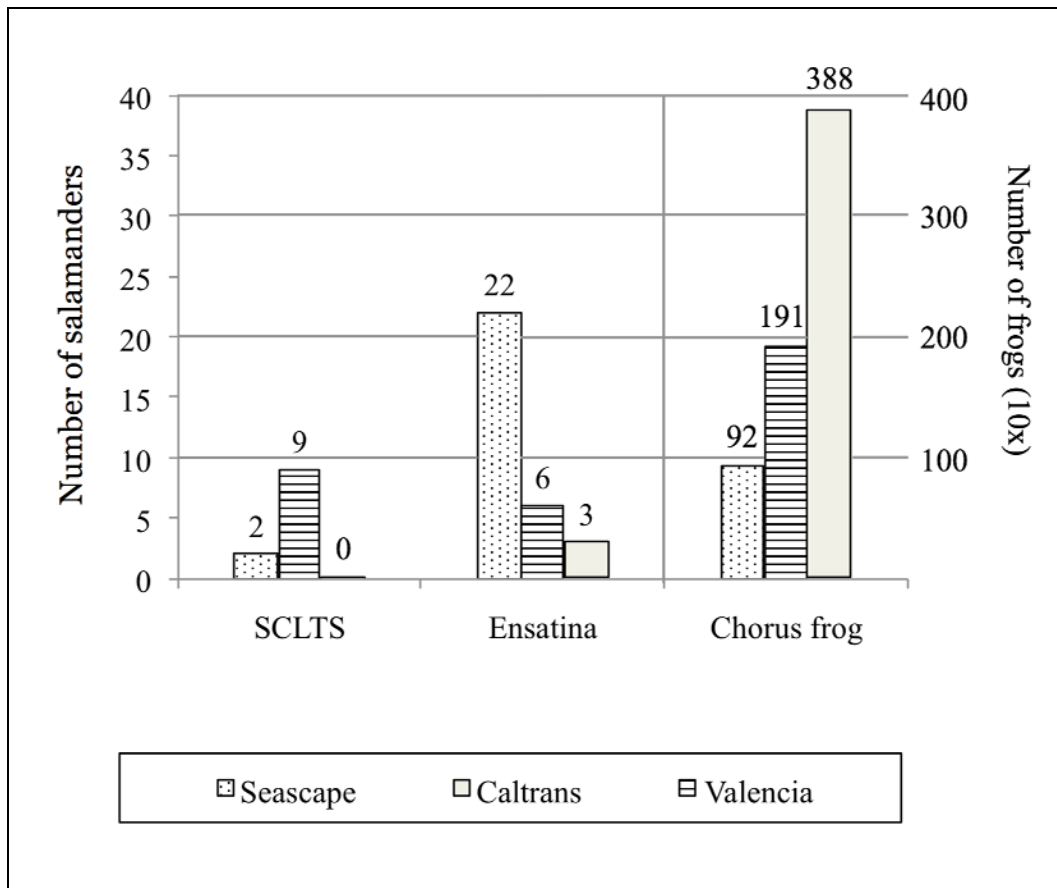

FIG. 9.—Species abundance by site. Scale for Pacific chorus frog is 10x larger than for all other species.

There was a significant positive relationship between the amount of precipitation within 24 hours and abundance of Pacific chorus frogs ($r_{(61)} = 0.36, p = 0.002$; Fig. 10). SCLTS and *Ensatina* numbers were too few to analyze.

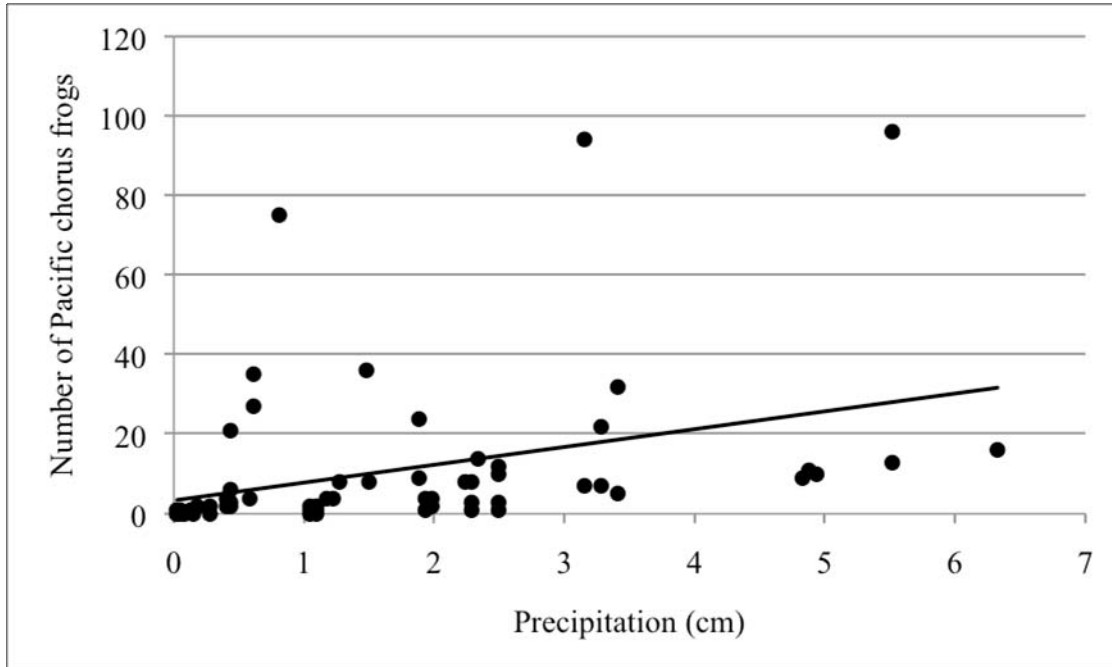

FIG. 10.—Number of Pacific chorus frogs associated with precipitation within 24 hours.

Results for average number of vehicles/hour at each site (Fig. 11) showed no interaction between study sites and hourly time-period ($F_{(4, 63)} = 0.49, p = 0.745$). However, vehicles/hour varied significantly by hourly time-period ($F_{(2, 63)} = 37.45, p = 0.000$). Post-hoc analysis showed significantly more vehicles in the 1700 h – 1800 h time-period ($\bar{x} = 43, SE = 2.4$) than the 1800 h – 1900 h time-period ($\bar{x} = 31, SE = 1.6$) or 1900 h – 2000 h time-period ($\bar{x} = 22, SE = 1.2$). In addition, there were significantly more vehicles in the 1800 h – 1900 h time-period than the 1900 h – 2000 h time-period.

This analysis also showed a significant difference in vehicles/hour by study site ($F_{(2, 63)} = 8.30, p = 0.001$). Post-hoc analysis showed no significant difference between Seascape ($\bar{x} = 35, SE = 2.8$) and Valencia ($\bar{x} = 35, SE = 2.3$), while there were significantly more vehicles/hour at Seascape and Valencia than Caltrans ($\bar{x} = 27, SE = 2.1$).

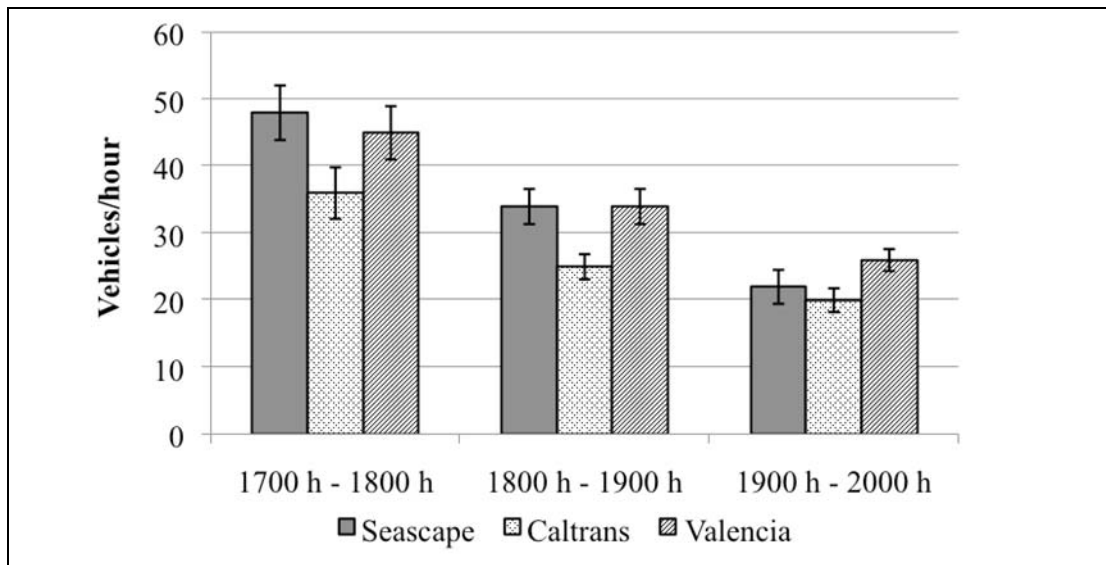

FIG. 11.—Average number of vehicles/hour at three sites in hourly time-periods from 1700 h – 2000 h.

Total traffic includes both residential traffic and through traffic. Total vehicles/hour at the Valencia site ($\bar{x} = 35, SE = 2.3$) was significantly greater than at the Caltrans site ($\bar{x} = 27, SE = 2.1; t_{(46)} = -2.772, p = 0.008$; Fig. 12).

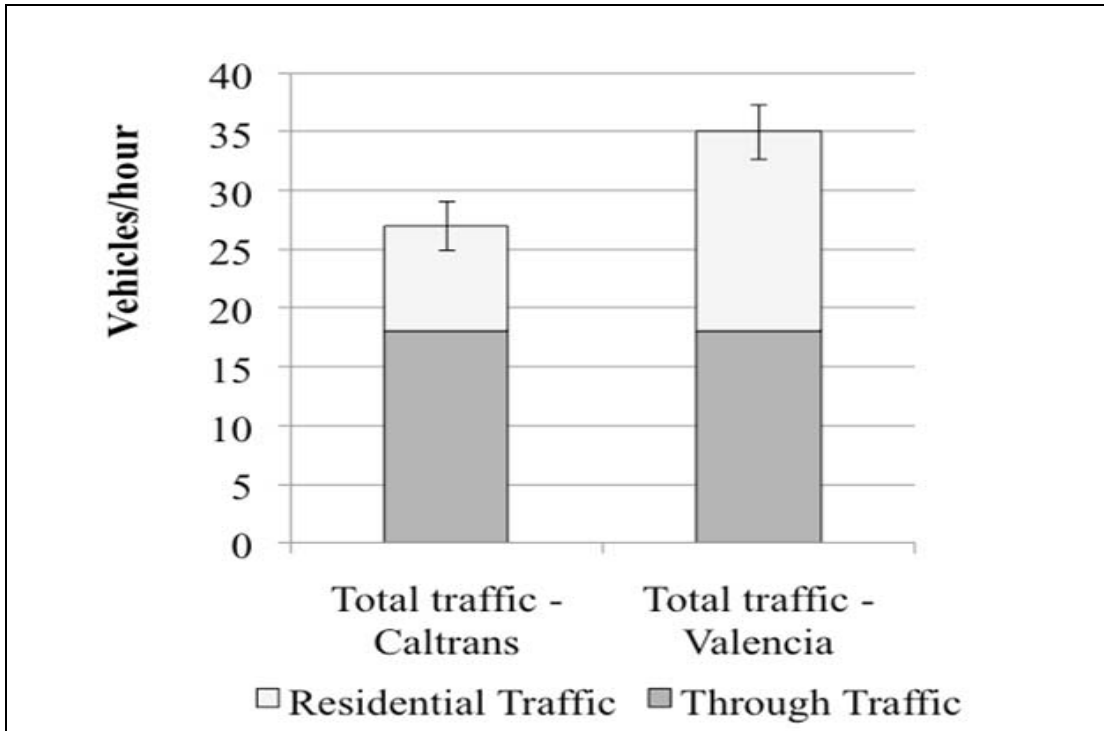

FIG. 12.—Average number of total vehicles/hour from 1700 h – 2000 h.

Because Caltrans and Valencia sites are co-located, through traffic is the same for each ($\bar{x} = 18$ vehicles/hour, $SE = 1.7$; Fig. 13). However, residential traffic attributable to people living in the area were different. Residential vehicles/hour at Valencia ($\bar{x} = 17$, $SE = 1.0$) was significantly higher than residential vehicles/hour at Caltrans ($\bar{x} = 9$, $SE = 0.7$; $F_{(2, 69)} = 24.930$, $p = 0.000$). Through traffic at Caltrans was 67% of total traffic. Through traffic at Valencia was 51% of total traffic.

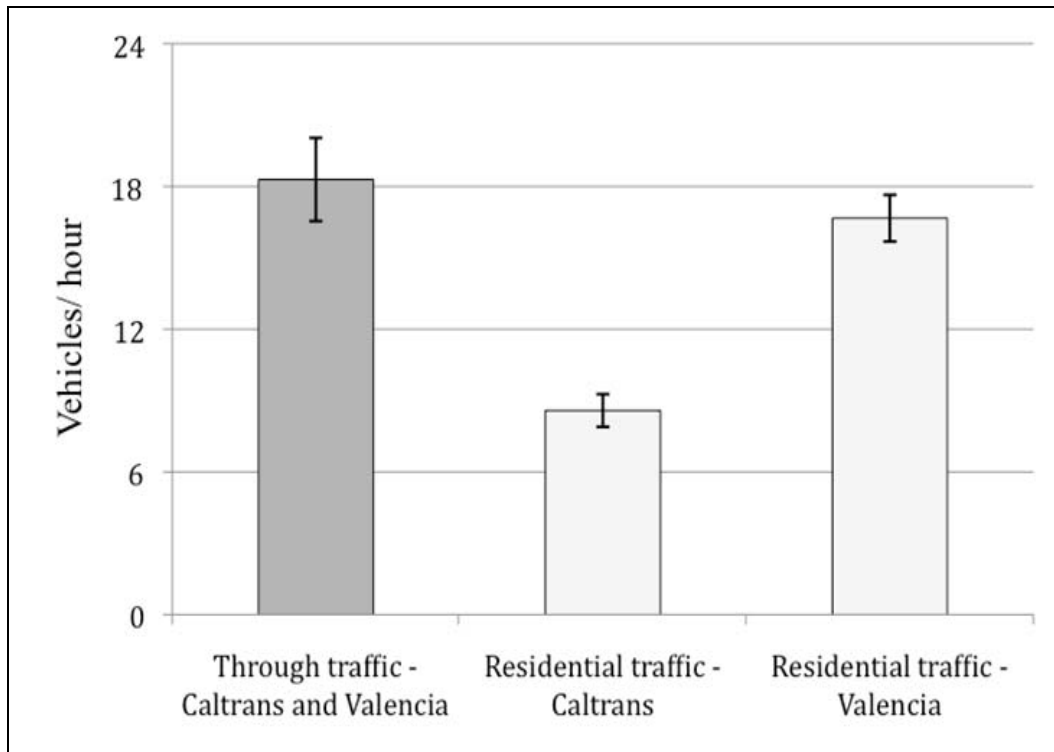

FIG. 13.—Average number of residential and through vehicles/hour from 1700 h – 2000 h.

Average percentage of *Pseudacris regilla* mortality/night does not reflect average vehicle/hour differences among sites (Fig. 14). Though average vehicles/hour are higher at Seascap and Valencia than Caltrans, differences in average percentage of *Pseudacris regilla* mortality/night among sites are not significant.

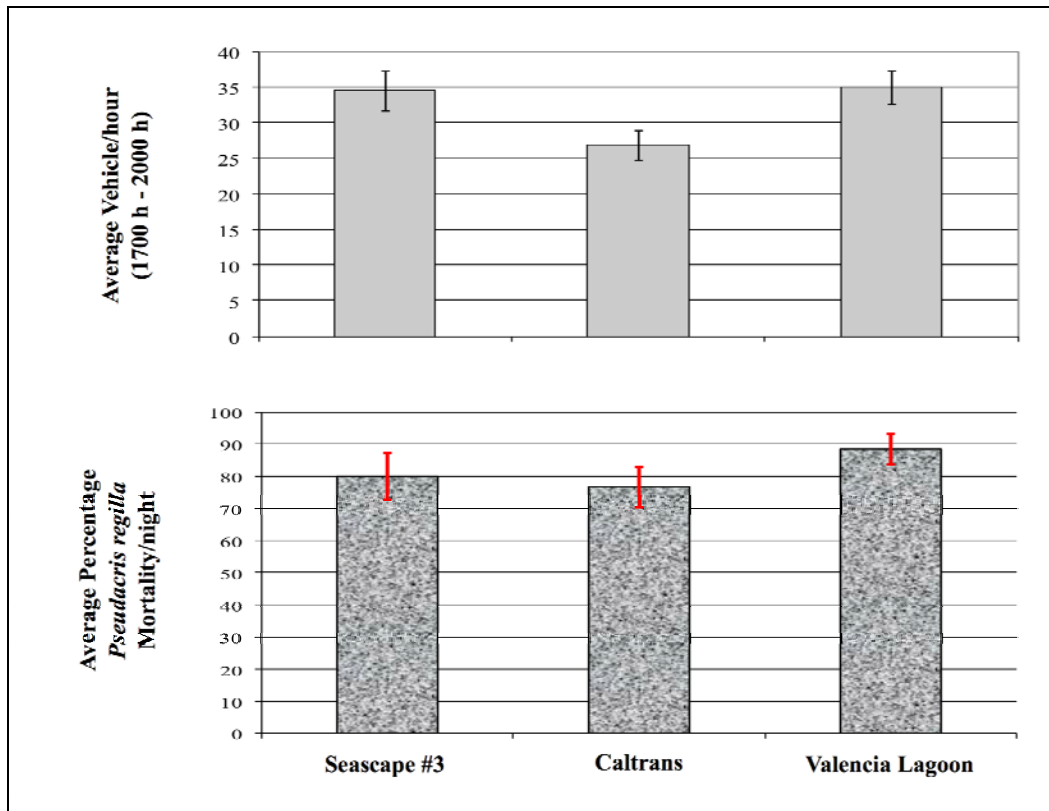

FIG. 14.—Comparison of *Pseudacris regilla* mortality (DOR) to average vehicles/hour among sites.

There were 83 days of measureable precipitation within the two winter SCLTS breeding migration seasons (2011-2013) on Bonita Drive, 24 of those days occurred prior to accumulating the 10.7 cm threshold required for adult movement (Appendices 1, 2; Table 7). Multiplying the days of precipitation by hours of observation/night provided the total number of migration hours (t_{total}). At Seascape the estimated total number of SCLTS likely killed was 17, prior to the 10.7 cm threshold there were none. At Valencia the estimated total number of SCLTS likely killed was 117, prior to the 10.7 cm threshold there were 48.

Table 5.—Estimated number of SCLTS likely killed during two winter breeding migration seasons (2011-13).

Site	Precipitation	Precipitation days 2011-13	Obs hrs / night	t_{total}	t_{Obs}	n DOR- Obs	n DOR- total
Seascape	prior to 10.7 cm	24	4	96	8	0	0
	total	83	4	332	20	1	17
Valencia	prior to 10.7 cm	24	4	96	8	4	48
	total	83	4	332	17	6	117

DISCUSSION

Urban development and the human population in Santa Cruz County have increased, both of which have increased traffic levels. Of the SCLTS Reed (1978) counted on Bonita Drive across from Valencia Lagoon, 5% were found dead, having expended 338 hours. In this study 67% of the SCLTS observed were found dead, having expended 192 hours. Increased traffic levels since 1978 are resulting in great mortality. Based on the number of animals found, an estimated minimum of 134 SCLTS were killed by vehicles over two seasons (2011-13), showing that migration across Bonita Drive is a significant mortality factor for SCLTS populations.

Traffic on Bonita Drive is a serious barrier for SCLTS. At the highest traffic rate of 45 vehicles/hour at Valencia, a SCLTS would have an average of one minute and thirty-three seconds between vehicles to cross the road. We found 51% of the traffic on Bonita Drive adjacent to Valencia was due to ‘through’ traffic. These are vehicles that

are not accessing homes but are passing through. These vehicles could be on Highway 1 or Soquel Drive, rather than Bonita Drive. If the average 18 vehicles/hour of through traffic were eliminated from Valencia, only 17 residential vehicles/hour would use the road, and mortality would likely decrease dramatically, perhaps by half.

Roadkill observations at Seascape were much fewer than those observed at Valencia. The highest rate of 48 vehicles/hour would give SCLTS an average one minute and fifteen seconds to traverse the 10 m of road, if only traversing perpendicular. The shorter time intervals between vehicles combined with a wider stretch make conditions worse for Seascape populations. The 2012-13 SCLTS population study at Seascape Pond #3 showed a threefold drop in populations 5 years prior, from 2007-08 to 2012-13. Results from the current limited study suggest that traffic on Bonita Drive has certainly contributed to the population decline of this rare species.

Salamanders at other locations are protected during their vulnerable migration via road closures or restrictions. At Tilden Regional Park in Berkeley California, the California newt (*Taricha torosa*) migrates to and from its terrestrial habitat by crossing South Park Drive every season to breed at Wildcat Creek. This road is closed every year from 1 November to 1 April. At Stanford University in Palo Alto, California, the California tiger salamander (CTS), listed as vulnerable, migrates across Junipero Serra Boulevard in order to breed at Lake Lagunita. Several ponds were built south of Lake Lagunita to offer alternative breeding grounds away from the road. Two ponds now support breeding CTS as well as Pacific chorus frogs, California toads, and many other invertebrates. The Bonnyvale Environmental Education Center (BEEC) in West

Brattleboro, VT, is a member-based non-profit organization that develops ecologically informed citizenry and supports a “crossing guard” program for salamanders.

“Salamander crossing” signs have also helped in sharing awareness and protecting animals from being run over.

SCLTS were primarily found at the Valencia site. This area differs from Seascape and Caltrans in that eight parcels on the residential side of the road are designated Resource Conservation, protecting SCLTS. The entire lagoon side is also designated Resource Conservation, protecting SCLTS. These conditions provide more suitable habitat for the SCLTS and this area warrants road closure during SCLTS migrations.

The Caltrans site is primarily residential with one empty parcel on the residential side, zoned as parks recreation and open space, protecting SCLTS. On the channel/pond side of the road a permanent salamander barrier was installed between Bonita Drive and Caltrans channel/pond. The barrier runs along the waterway for the purpose of restricting SCLTS from entering the channel/pond area, as well as preventing salamanders from migrating in the direction of Highway 1. This study shows that at Caltrans, with its lowest traffic rate and further potential to reduce through traffic, is a site that could be enhanced to encourage salamander populations. In fact, this site once supported SCLTS breeding, having discovered eggs, in areas retaining water (Reed 1978). Two key management actions for enhancing the Caltrans site are to move the salamander barrier to the opposite side of the channel/pond and prohibit through traffic during all migration seasons.

Vehicular traffic impacts species other than the SCLTS. By far the most commonly killed species was the Pacific chorus frog. We counted 514, of which 77% were dead, a greater percentage than either SCLTS or yellow-eyed ensatina. Most were killed on evenings when rain was heaviest, however several big events occurred when the rain was heaviest in the daytime and lighter in the evening. Mortality may have been so high because Pacific chorus frogs come out during twilight hours when traffic is heaviest. These frogs were most common at Caltrans, perhaps because 13 houses line the road. Pacific chorus frogs live in low, moist, vegetated shelters during the dry season and it is possible that residential irrigation has created an ideal shelter for harboring these animals. The salamander barrier restricts access to the pond keeping salamander populations at bay, however the Chorus frog with their toe pads are able to climb, making it possible to scale the barrier and breed in the pond.

Pseudacris regilla road mortality can be used as a metric to measure overall amphibian road mortality, particularly that of *A. m. croceum*. Though there was no significant difference in average percentage of mortality per night across all three sites, there was a trend in mean averages and vehicles/hour between Caltrans and Valencia. This trend can be used to measure mitigation affects in the area.

With nine yellow-eyed ensatina killed out of 31 observed, they had the lowest percent mortality (29%). The Ensatina life history pattern is land/land, which differs from those of both SCLTS and Pacific chorus frog, having a life history pattern of water/land. Ensatina are not driven towards bodies of water for breeding and were not compelled to cross the road. Their presence on the road may stem from food

opportunities as invertebrates are flushed from rain. They are known to stay relatively close to their home range, possibly skirting the edges of the road. *Ensatina* were most commonly found at Seascap. This site differs from the Caltrans and Valencia sites in that the area is more rural, and has hills on both sides of the road. The south-facing hill opposite the pond is primarily hilly grassland with trees spread out sparsely, primarily oaks. This area is very dry in the summer. The north-facing hill is densely covered with thick vegetation made up of duff, wood debris, vines, bushes and trees. The ground is shaded and is slightly lower in elevation, receiving water runoff in the winter. Seascap may favor *Ensatina* because of its open space and possible richness of insects.

Populations of the critically endangered Santa Cruz long-toed salamander are being compromised as a direct result of vehicles driving across roads separating the animals' terrestrial and aquatic habitats. Much of the traffic is unnecessary. Initial concerns stemming from a report 24 years after the discovery of this disjunct population have come to fruition as road mortality is hindering the recovery of SCLTS. Human population increase and natural habitat loss have long been factors affecting the displacement, reduction, and even elimination of animal populations. This study suggests that traffic loads on Bonita Drive during breeding migrations are a primary factor in the decline of SCLTS populations.

RECOMMENDATIONS

Based on the findings of this research, management recommendations to improve conditions for SCLTS in habitats along Bonita Drive include:

- (1) Reduce or eliminate through traffic on Bonita Drive between Freedom Boulevard and Rio del Mar Boulevard by instituting a Residential Only Zone. Install signage at both entrances at Freedom Boulevard and Rio del Mar Boulevard informing vehicle operators that the road is not a through street. Make “freeway hopping” illegal and institute fines.
- (2) Add speed bumps to reduce speed and make through traffic an unattractive alternative.
- (3) Employ nighttime traffic control directors to manage the safe crossing of juvenile recruits during their initial mass emigration, first rains of season.
- (4) Install structures to assist animal movement. One structure is the ASPT System (Appendix 7).
- (5) Enhance Caltrans drainage channel/pond to encourage SCLTS populations by moving salamander barrier to opposite side of channel/pond.
- (6) Establish a community ‘crossing guard’ program for protecting SCLTS and all amphibians on Bonita Drive.

Possible future studies can:

- (1) Continue Bonita Drive mortality methodology in this study for an additional three years to in order to better balance seasonal rain patterns and increase sample sizes, totaling five years.
- (2) Conduct SCLTS population studies in parallel with SCLTS road mortality studies.

LITERATURE CITED

- Allaback, M.L., and D.M. Laabs. 2003. Effectiveness of road tunnels for the Santa Cruz Long-Toed Salamander. *Transactions of the Western Section of the Wildlife Society* 38:5-8.
- Allaby, M. 2010. *Oxford dictionary of ecology*. 4th ed. Oxford University Press. USA.
- AmphibiaWeb: Information on amphibian biology and conservation. [web application]. 2013. Berkeley, California: AmphibiaWeb. Available: <http://amphibiaweb.org/> (Accessed: Oct 21, 2013). Archived by WebCite at <http://www.webcitation.org/6KXrY7RIj> on 21 October 2013.
- Anderson, J.D. 1966. A comparison of the life histories of coastal and montane populations of *Ambystoma macrodactylum* in California. *American Midland Naturalist* 77:323-355.
- Beebee, T.J. 2012. Effects of road mortality and mitigation measures on amphibian populations. *Conservation Biology* 27:657-668.
- Bury, R.B., and S.B. Ruth. 1972. Santa Cruz long-toed salamander; survival in doubt. *Herpetologica* 4:20-22.
- CDFW (California Department of Fish and Wildlife). 2013. State & Federally listed endangered & threatened animals of California. Available at <http://www.dfg.ca.gov/biogeodata/cnddb/pdfs/TEAnimals.pdf>. Archived by WebCite at <http://www.webcitation.org/6KbCy6V8N> on 23 October 2013.
- Caltrans (California Department of Transportation). 2009. *Wildlife Crossings Guidance Manual*. Available at http://www.dot.ca.gov/hq/env/bio/wildlife_crossings/files/guidance_manual.pdf. Archived by WebCite at <http://www.webcitation.org/6KbDRHXve> on 23 October 2013.

- CROS (California Roadkill Observation System). 2011. Available at <http://www.wildlifecrossing.net/california/>. Archived by WebCite at <http://www.webcitation.org/6KbDrAfGM> on 23 October 2013.
- Carr, L.W., and L. Fahrig. 2001. Effect of road traffic on two amphibian species of differing vagility. *Conservation Biology* 15:1071-1078.
- Czech B., P.R. Krausman, and P.K. Devers. 2000. Economic Associations among causes of species endangerment in the United States. *BioScience* 50:593-601.
- Dahl, T.E. 1990. Wetlands losses in the United States 1780's to 1980's. U.S. Department of the interior, Fish and Wildlife Service, Washington, D.C. 13pp.
- Eigenbrod, F., S.J. Hecnar, and L. Fahrig. 2008. The relative effects of road traffic and forest cover on anuran populations. *Biological Conservation* 141:35-46.
- Faivovich, J., C.F. Haddad, P.C. Garcia, D.R. Frost, J.A. Campbell, and W.C. Wheeler. 2005. Systematic review of the frog family Hylidae, with special reference to Hylinae: Phylogenetic analysis and taxonomic revision. *American Museum of Natural History* 294:1-240.
- Fahrig, L., J.H. Pedlar, S.E. Pope, P.D. Taylor, and J.F. Wegner. 1995. Effect of road traffic on amphibian density. *Biological Conservation* 73:177-182.
- Ferguson, D.E. 1961. The geographic variation of *Ambystoma macrodactylum* Baird, with the descriptions of two new species. *American Midland Naturalist* 65:311-338.
- Forman, R.T. 2000. Estimate of the area affected ecologically by the road system in the United States. *Society for Conservation Biology* 14:31-35.
- Forman, R.T., D. Sperling, J.A. Bissonette, A.P. Clevenger, C.D. Cutshall, V.H. Dale, L. Fahrig, R. France, C.R. Goldman, K. Heanue, J.A. Jones, F.J. Swanson, T. Turrentine, and T.C. Winter. 2003. Road ecology: science and solutions. Island Press, USA.

- Glista, D.J., T.L. DeVault, and J.A. DeWoody. 2009. A review of mitigation measures for reducing wildlife mortality on roadways. *Landscape and Urban Planning* 91:1-7.
- Gordon, B.L. 1996. *Monterey Bay area: Natural history and cultural imprints*. 3rd ed. The Boxwood Press, USA.
- Hayes, T.B. 2004. There is no denying this: Defusing the confusion about atrazine. *BioScience* 54:1138-1149.
- Hels, T., and E. Buchwald. 2001. The effect of road kills on amphibian populations. *Biological Conservation* 99:331-340.
- IUCN (International Union for Conservation of Nature). 2013. Status category summary by major taxonomic group (animals). Available at http://www.iucnredlist.org/documents/summarystatistics/2013_1_RL_Stats_Table_3a.pdf. Archived by WebCite at <http://www.webcitation.org/6KbE4UCkb> on 23 October 2013.
- Kuchta, S.R. 2005. Experimental support for Aposematic coloration in the salamander *Ensatina eschscholtzii xanthoptica*: Implications for mimicry of pacific newts. *Copeia* 2005:265-271.
- Lalo, J. 1987. The problem of road kill. *American Forests* 93:50-52.
- Marsh, D.M., and P.C. Trenham. 2001. Metapopulation dynamics and amphibian conservation. *Conservation Biology* 15:40-49.
- Mattison, C. 2011. *Frogs and toads of the world*. Princeton University Press, USA.
- Mazerolle, M.J., M. Hout, and M. Gravel. 2005. Behavior of amphibians on the road in response to car traffic. *Herpetologica* 61:380-388.
- McCallum, M.L. 2007. Amphibian Decline or Extinction? Current declines dwarf background extinction rate. *Journal of Herpetology* 41:483-491.

- McKinney, M.L. 2002. Urbanization, biodiversity, and conservation. *Bioscience* 52: 883-890.
- Petranka, J.W. 1998. Salamanders of the United States and Canada. Smithsonian Institution Press, USA.
- Reed, R.J. 1978. Population study of the Santa Cruz long-toed salamander (*Ambystoma Macrodictylum croceum*) at Valencia Lagoon 1977-1978, with notes on habitat and occurrences in Santa Cruz and Monterey counties. Calif. Dept. Fish & Game, contract S-1180.
- Rubbo, M.J., and J.M. Kiesecker. 2004. Amphibian breeding distribution in an urbanized landscape. *Conservation Biology* 19:504-511.
- Russell, R.W., and J.D. Anderson. 1956. A disjunct population of the long-nosed [sic] salamander from the coast of California. *Herpetologica* 12:137-140.
- Ruth, S.B. 1974. The current status of the Santa Cruz long-toed salamander—an endangered animal. *Herpetological review* 5:27-28.
- Ruth, S.B. 1988. The life history and current status of the Santa Cruz long-toed salamander, *Ambystoma macrodictylum croceum*. Proceedings of the Conference on California Herpetology. Southwestern Herpetologists Society (USA) 4:98-110.
- SCCRTC (Santa Cruz County Regional Transportation Commission). 2000. County Commute Patterns: 1980 to 2000. Appendix H, Table 1: Commuters within Santa Cruz County. Available at <http://sccrtc.org/wp-content/uploads/2010/09/apdxH-1.pdf>. Archived by WebCite at <http://www.webcitation.org/6KbFIJy8Y> on 23 October 2013.
- SCCRTC (Santa Cruz County Regional Transportation Commission). 2011. Santa Cruz County traffic counts. Available at <http://sccrtc.org/wp-content/uploads/2011/07/2011-06-adt-counts.pdf>. Archived by WebCite at <http://www.webcitation.org/6KbFTq8Ua> on 23 October 2013.

- Scott, M.J., F.W. Davis, R.G. McGhie, R.G. Wright, G. Groves, and J. Estes. 2001. Nature reserves: do they capture the full range of America's biological diversity? *Ecological Applications* 11:999-1007.
- Shilling, F. 2007. Repairing road system impacts on landscape connectivity. *Transactions of the western section of the Wildlife Society* 43:11-18.
- Smith, M.A., and D.M. Green. 2005. Dispersal and the metapopulation paradigm in amphibian ecology and conservation: are all amphibian populations metapopulations? *Ecography* 28:110-128.
- Stebbins, R.C. 1949. *Speciation in salamanders of the plethodontid genus Ensatina*. University of California Press, USA.
- Stebbins, R.C. 2003. *A field guide to western reptiles and amphibians*. 3rd edition. Houghton Mifflin Company, USA.
- Stuart, S.N., J.S. Chanson, N.A. Cox, B.E. Young, A.S. Rodrigues, D.L. Fischman, and R.W. Waller. 2004. Status and trends of amphibian declines and extinctions worldwide. *Science* 306:1783-1786.
- Trombulak, S.C., and C.A. Frissell. 2000. Review of ecological effects of roads on terrestrial and aquatic communities. *Conservation Biology* 14:18-30.
- U.S. Census Bureau. 1995. California: Population of counties by decennial census: 1900 to 1990. Available at <http://www.census.gov/population/www/censusdata/cencounts/files/ca190090.txt>. Archived by WebCite at <http://www.webcitation.org/6KbFksfZb> on 23 October 2013.
- U.S. Census Bureau. 2010. 2010 Census interactive population search. Available at <http://www.census.gov/2010census/popmap/ipmtext.php?fl=06>. Archived by WebCite at <http://www.census.gov/2010census/popmap/ipmtext.php?fl=06> on 23 October 2013.

- USDOI (U. S. Department of the Interior). 1967. Native fish and wildlife: Endangered species. Federal Register 32:4001.
- USDOI (U.S. Department of the Interior). 1978. Proposed determination of critical habitat for the SCLTS. Federal Register 43:26759.
- USFWS (U.S. Fish and Wildlife Service). 1999. Draft revised recovery plan for the Santa Cruz long-toed salamander. Available at http://ecos.fws.gov/docs/recovery_plan/990702.pdf. Archived by WebCite at <http://www.webcitation.org/6KbIISvr1> on 23 October 2013.
- USFWS (U.S. Fish and Wildlife Service). 2009a. Santa Cruz long-toed salamander (*Ambystoma macrodactylum croceum*), 5-year review: Summary and evaluation. Available at http://ecos.fws.gov/docs/five_year_review/doc2630.pdf. Archived by WebCite at <http://www.webcitation.org/6KbIYhvkf> on 23 October 2013.
- USFWS (U.S. Fish and Wildlife Service). 2009b. Box score. Endangered species bulletin 34:43. Available at http://www.fws.gov/Endangered/bulletin/2009/bulletin_summer2009-all.pdf. Archived by WebCite at <http://www.webcitation.org/6KbIlnOfk> on 23 October 2013.
- van Gelder, J.J. 1973. A quantitative approach to the mortality resulting from traffic in a population of *Bufo bufo* L. *Oecologia* 13:93-95.
- Wake, D.B., and V.T. Vredenburg. 2008. Are we in the midst of the sixth mass extinction? A View from the World of Amphibians. *National Academy of Sciences* 105:11466-11473.
- WRCC (Western Regional Climate Center). 2006. General climate summary tables. Available at <http://www.wrcc.dri.edu/cgi-bin/cliMAIN.pl?casru+nca>. Archived by WebCite at <http://www.webcitation.org/6KbIu02v1> on 23 October 2013.
- Wilcox, B.A., and D.D. Murphy. 1985. Conservation strategy: The effects of fragmentation on extinction. *The American Naturalist* 125:879-887.

APPENDIX 1. SEASON 1 PRECIPITATION/OBSERVATION DATA

Precipitation data: November 01, 2011 to March 30, 2012 (Season 1). Measured from CIMIS De Laveaga station 104. Precipitation—inches. Including all events.

Season	Daily Precipitation	Accumulated Precipitation	Seascape	Caltrans	Valencia	<i>Zero amphibians</i>
1						
Date						
11/1/11	0	0.00				
11/2/11	0	0.00				
11/3/11	0.09	0.09	7-8pm	8-9pm	9-10pm	
11/4/11	0.12	0.21				
11/5/11	0.66	0.87				
11/6/11	0.09	0.96				
11/7/11	0	0.96				
11/8/11	0	0.96				
11/9/11	0	0.96				
11/10/11	0	0.96				
11/11/11	0.52	1.48	7-8pm	8-9pm	9-10pm	
11/12/11	0	1.48				
11/13/11	0	1.48				
11/14/11	0	1.48				
11/15/11	0	1.48				
11/16/11	0	1.48				
11/17/11	0	1.48				
11/18/11	0.02	1.50	9-10pm	8-9pm	7-8pm	
11/19/11	0.38	1.88				
11/20/11	0.6	2.48				
11/21/11	0.01	2.49				
11/22/11	0.01	2.50				
11/23/11	0	2.50				
11/24/11	0.13	2.63				
11/25/11	0	2.63				
11/26/11	0	2.63				
11/27/11	0	2.63				
11/28/11	0	2.63				
11/29/11	0	2.63				
11/30/11	0	2.63				
12/1/11	0	2.63				
12/2/11	0	2.63				
12/3/11	0	2.63				
12/4/11	0	2.63				
12/5/11	0	2.63				
12/6/11	0	2.63				
12/7/11	0	2.63				
12/8/11	0	2.63				
12/9/11	0	2.63				
12/10/11	0	2.63				

Season 1	Daily Precipitation	Accumulated Precipitation	Seascape	Caltrans	Valencia
12/11/11	0.03	2.66			
12/12/11	0	2.66			
12/13/11	0	2.66			
12/14/11	0	2.66			
12/15/11	0.11	2.77			
12/16/11	0	2.77			
12/17/11	0	2.77			
12/18/11	0	2.77			
12/19/11	0	2.77			
12/20/11	0	2.77			
12/21/11	0	2.77			
12/22/11	0	2.77			
12/23/11	0	2.77			
12/24/11	0	2.77			
12/25/11	0	2.77			
12/26/11	0	2.77			
12/27/11	0	2.77			
12/28/11	0	2.77			
12/29/11	0	2.77			
12/30/11	0	2.77			
12/31/11	0	2.77			
1/1/12	0	2.77			
1/2/12	0	2.77			
1/3/12	0	2.77			
1/4/12	0	2.77			
1/5/12	0	2.77			
1/6/12	0	2.77			
1/7/12	0	2.77			
1/8/12	0	2.77			
1/9/12	0	2.77			
1/10/12	0	2.77			
1/11/12	0	2.77			
1/12/12	0	2.77			
1/13/12	0	2.77			
1/14/12	0	2.77			
1/15/12	0	2.77			
1/16/12	0	2.77			
1/17/12	0	2.77			
1/18/12	0	2.77			
1/19/12	0.12	2.89	7-8pm	7-8pm	8-9pm
1/19/12	0.12	2.89	8-9pm	9-10pm	
1/20/12	1.44	4.33	7-8pm	7-8pm	8-9pm
1/20/12	1.44	4.33	8-9pm	9-10pm	
1/20/12	1.44	4.33	9-10pm		
1/21/12	0.67	5.00			
1/22/12	0.18	5.18	7-8pm	8-9pm	7-8pm
1/22/12	0.18	5.18	8-9pm		9-10pm

**Zero
amphibians**

Season 1	Daily Precipitation	Accumulated Precipitation	Seascape	Caltrans	Valencia	Zero amphibians
Date			9-10pm			
1/22/12	0.18	5.18				
1/23/12	0.46	5.64				
1/24/12	0.41	6.05				
1/25/12	0.39	6.44				
1/26/12	0.07	6.51				
1/27/12	0	6.51				
1/28/12	0	6.51				
1/29/12	0	6.51				
1/30/12	0	6.51				
1/31/12	0	6.51				
2/1/12	0	6.51				
2/2/12	0	6.51				
2/3/12	0	6.51				
2/4/12	0	6.51				
2/5/12	0	6.51				
2/6/12	0.05	6.56				
2/7/12	0.06	6.62		7-8pm	8-9pm	
2/8/12	0	6.62				
2/9/12	0	6.62				
2/10/12	0	6.62				
2/11/12	0	6.62				
2/12/12	0.08	6.70				
2/13/12	0.33	7.03				
2/14/12	0	7.03				
2/15/12	0.06	7.09				
2/16/12	0	7.09				
2/17/12	0	7.09				
2/18/12	0	7.09				
2/19/12	0	7.09				
2/20/12	0.01	7.10				
2/21/12	0	7.10				
2/22/12	0	7.10				
2/23/12	0	7.10				
2/24/12	0	7.10				
2/25/12	0	7.10				
2/26/12	0	7.10				
2/27/12	0	7.10				
2/28/12	0	7.10				
2/29/12	0.4	7.50				
3/1/12	0.29	7.79				
3/2/12	0	7.79				
3/3/12	0	7.79				
3/4/12	0	7.79				
3/5/12	0	7.79				
3/6/12	0	7.79				
3/7/12	0	7.79				
3/8/12	0	7.79				

Season 1	Daily Precipitation	Accumulated Precipitation	Seascape	Caltrans	Valencia	Zero amphibians
Date						
3/9/12	0	7.79				
3/10/12	0	7.79				
3/11/12	0	7.79				
3/12/12	0	7.79				
3/13/12	0.59	8.38	9-10pm	8-9pm		
3/14/12	1.96	10.34				
3/15/12	0.65	10.99				
3/16/12	0.83	11.82				
3/17/12	0.76	12.58				
3/18/12	0.13	12.71				
3/19/12	0	12.71				
3/20/12	0	12.71				
3/21/12	0	12.71				
3/22/12	0	12.71				
3/23/12	0	12.71				
3/24/12	0.89	13.60				
3/25/12	0.24	13.84				
3/26/12	0	13.84				
3/27/12	0.39	14.23				
3/28/12	0.06	14.29				
3/29/12	0	14.29				
3/30/12	0	14.29				

APPENDIX 2. SEASON 2 PRECIPITATION/OBSERVATION DATA

Precipitation data: November 01, 2012 to March 30, 2013 (Season 2). Measured from CIMIS De Laveaga station 104. Precipitation—inches. Including all events.

Season	Daily Precipitation	Accumulated Precipitation	Seascape	Caltrans	Valencia
2					
					<i>Zero amphibians</i>
Date					
11/1/12	0.22	0.22			
11/2/12	0	0.22			
11/3/12	0	0.22			
11/4/12	0	0.22			
11/5/12	0	0.22			
11/6/12	0	0.22			
11/7/12	0	0.22			
11/8/12	0.11	0.33			
11/9/12	0.08	0.41			
11/10/12	0	0.41			
11/11/12	0	0.41			
11/12/12	0	0.41			
11/13/12	0	0.41			
11/14/12	0	0.41			
11/15/12	0	0.41			
11/16/12	0.44	0.85	6pm-7pm	7pm-8pm	8pm-9pm
11/16/12	0.44	0.85			9pm-10pm
11/17/12	1.04	1.89	7pm-8pm	8pm-9pm	9pm-10pm
11/18/12	0.34	2.23			
11/19/12	0	2.23			
11/20/12	0.05	2.28			
11/21/12	1.22	3.5			
11/22/12	0	3.5			
11/23/12	0	3.5			
11/24/12	0	3.5			
11/25/12	0	3.5			
11/26/12	0	3.5			
11/27/12	0	3.5			
11/28/12	0.43	3.93	7pm-8pm	6pm-7pm	6pm-7pm
11/29/12	0.14	4.07			
11/30/12	1.9	5.97	9pm-10pm	7pm-8pm	8pm-9pm
12/1/12	0.85	6.82	7pm-8pm	7pm-8pm	8pm-9pm
12/2/12	1.1	7.92			
12/3/12	0	7.92			
12/4/12	0	7.92			
12/5/12	0.73	8.65			
12/6/12	0	8.65			
12/7/12	0	8.65			
12/8/12	0	8.65			
12/9/12	0	8.65			

Season 2	Daily Precipitation	Accumulated Precipitation	Seascape	Caltrans	Valencia
12/10/12	0	8.65			
12/11/12	0	8.65			
12/12/12	0.14	8.79			
12/13/12	0	8.79			
12/14/12	0	8.79			
12/15/12	0.17	8.96			
12/16/12	0.08	9.04	9pm-9:30pm	8pm-8:30pm	8:30-9pm
12/17/12	0.74	9.78	8:00-8:30pm	8:30-9pm	9-9:30pm
12/18/12	0.01	9.79			
12/19/12	0	9.79			
12/20/12	0	9.79			
12/21/12	0.42	10.21	7:45-8:15	8:30-9:00	8:30-9:00
12/22/12	0.92	11.13			
12/23/12	2.17	13.3	8:40-9:40pm	9:45-10:45pm	10:45-11:45pm
12/23/12	2.17	13.3	1-1:30am	1:30-2am	2-2:30am
12/24/12	0.01	13.31			
12/25/12	1.05	14.36	7:15-7:45pm	8-8:30pm	8:30-9:00pm
12/26/12	0.22	14.58			
12/27/12	0	14.58			
12/28/12	0.09	14.67			
12/29/12	0.26	14.93			
12/30/12	0	14.93			
12/31/12	0	14.93			
1/1/13	0	14.93			
1/2/13	0	14.93			
1/3/13	0	14.93			
1/4/13	0	14.93			
1/5/13	0.53	15.46			
1/6/13	0.11	15.57			
1/7/13	0	15.57			
1/8/13	0	15.57			
1/9/13	0.01	15.58			
1/10/13	0.02	15.6			
1/11/13	0	15.6			
1/12/13	0	15.6			
1/13/13	0	15.6			
1/14/13	0	15.6			
1/15/13	0	15.6			
1/16/13	0	15.6			
1/17/13	0	15.6			
1/18/13	0	15.6			
1/19/13	0	15.6			
1/20/13	0	15.6			
1/21/13	0	15.6			
1/22/13	0	15.6			
1/23/13	0.04	15.64			

**Zero
amphibians**

Season 2	Daily Precipitation	Accumulated Precipitation	Seascope	Caltrans	Valencia
Date					
1/24/13	0.21	15.85			
1/25/13	0	15.85			
1/26/13	0	15.85			
1/27/13	0	15.85			
1/28/13	0	15.85			
1/29/13	0	15.85			
1/30/13	0	15.85			
1/31/13	0	15.85			
2/1/13	0	15.85			
2/2/13	0	15.85			
2/3/13	0	15.85			
2/4/13	0	15.85			
2/5/13	0	15.85			
2/6/13	0	15.85			
2/7/13	0	15.85			
2/8/13	0.02	15.87			
2/9/13	0	15.87			
2/10/13	0	15.87			
2/11/13	0	15.87			
2/12/13	0	15.87			
2/13/13	0	15.87			
2/14/13	0	15.87			
2/15/13	0	15.87			
2/16/13	0	15.87			
2/17/13	0	15.87			
2/18/13	0	15.87			
2/19/13	0.3	16.17			
2/20/13	0	16.17			
2/21/13	0	16.17			
2/22/13	0	16.17			
2/23/13	0	16.17			
2/24/13	0	16.17			
2/25/13	0	16.17			
2/26/13	0	16.17			
2/27/13	0	16.17			
2/28/13	0	16.17			
3/1/13	0	16.17			
3/2/13	0	16.17			
3/3/13	0	16.17			
3/4/13	0	16.17			
3/5/13	0.28	16.45			
3/6/13	0.27	16.72			
3/7/13	0.23	16.95			
3/8/13	0.03	16.98			
3/9/13	0	16.98			
3/10/13	0	16.98			
3/11/13	0	16.98			
3/12/13	0	16.98			

**Zero
amphibians**

Season 2	Daily Precipitation	Accumulated Precipitation	Seascope	Caltrans	Valencia
3/13/13	0	16.98			
3/14/13	0	16.98			
3/15/13	0	16.98			
3/16/13	0	16.98			
3/17/13	0	16.98			
3/18/13	0	16.98			
3/19/13	0.11	17.09			
3/20/13	0.01	17.1			
3/21/13	0	17.1			
3/22/13	0	17.1			
3/23/13	0	17.1			
3/24/13	0	17.1			
3/25/13	0	17.1			
3/26/13	0	17.1			
3/27/13	0.07	17.17			
3/28/13	0.11	17.28			
3/29/13	0	17.28			
3/30/13	0.48	17.76			

**Zero
amphibians**

APPENDIX 3. FIELD DATA SHEET

DATE				DATE				DATE															
		ZONE	1	2	3			ZONE	1	2	3			ZONE	1	2	3						
		Time slot:								Time slot:								Time slot:					
<i>From</i>	<i>To</i>	SPECIES / METER / TIME (DOR)						<i>From</i>	<i>To</i>	SPECIES / METER / TIME (DOR)						<i>From</i>	<i>To</i>	SPECIES / METER / TIME (DOR)					
		/		/					/		/					/		/					
		/		/					/		/					/		/					
		/		/					/		/					/		/					
		/		/					/		/					/		/					
		/		/					/		/					/		/					
		/		/					/		/					/		/					
		/		/					/		/					/		/					
		/		/					/		/					/		/					
		/		/					/		/					/		/					
		/		/					/		/					/		/					
		/		/					/		/					/		/					
		/		/					/		/					/		/					
		/		/					/		/					/		/					
		/		/					/		/					/		/					
		/		/					/		/					/		/					
		/		/					/		/					/		/					
		/		/					/		/					/		/					
		/		/					/		/					/		/					
		/		/					/		/					/		/					
		/		/					/		/					/		/					
		/		/					/		/					/		/					
		/		/					/		/					/		/					
		/		/					/		/					/		/					
		/		/					/		/					/		/					
		/		/					/		/					/		/					
		/		/					/		/					/		/					
		/		/					/		/					/		/					
		/		/					/		/					/		/					
		/		/					/		/					/		/					
		/		/					/		/					/		/					
		/		/					/		/					/		/					
		/		/					/		/					/		/					
		/		/					/		/					/		/					
		/		/					/		/					/		/					
		/		/					/		/					/		/					

APPENDIX 4. DOR INDEX CARD

Date	_____													
Time	_____													
Degree	Minutes	Seconds	Heading											
N 36	_____	_____												
W 121	_____	_____												
DOR INDEX CARD														

APPENDIX 5. CAR COUNTER

Passing vehicles are recognized and tallied by their sound signature. As vehicles approached the car counter, sound levels gradually increase, reach a relatively high peak, and then gradually decrease (Fig. 15). Time duration and peak level (amplitude) are key to distinguishing a passing car from most other sound signatures such as persons walking, talking, biking, barking dogs, rain, low flying aircraft, and lawnmowers. Components were integrated onto a printed circuit board and encased in a water resistant housing unit for field operations

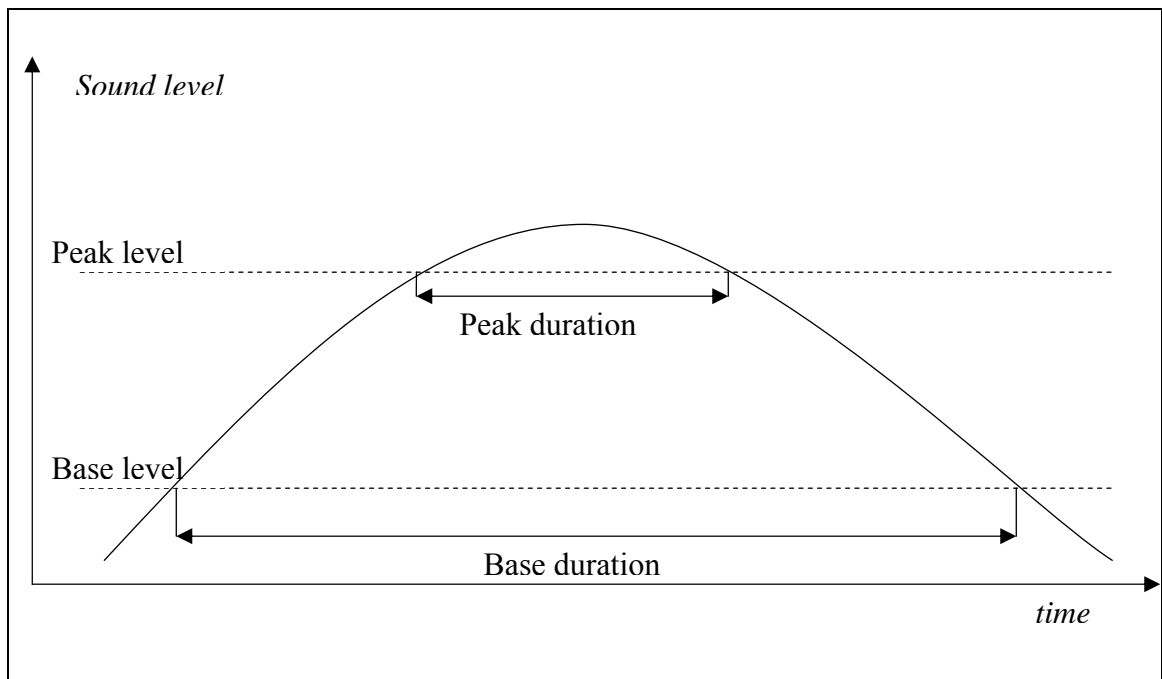

FIG. 15.—Sound signature of passing cars.

Hardware Overview

The printed circuit board was assembled with multiple components creating circuits of varying responsibilities (Fig. 16).

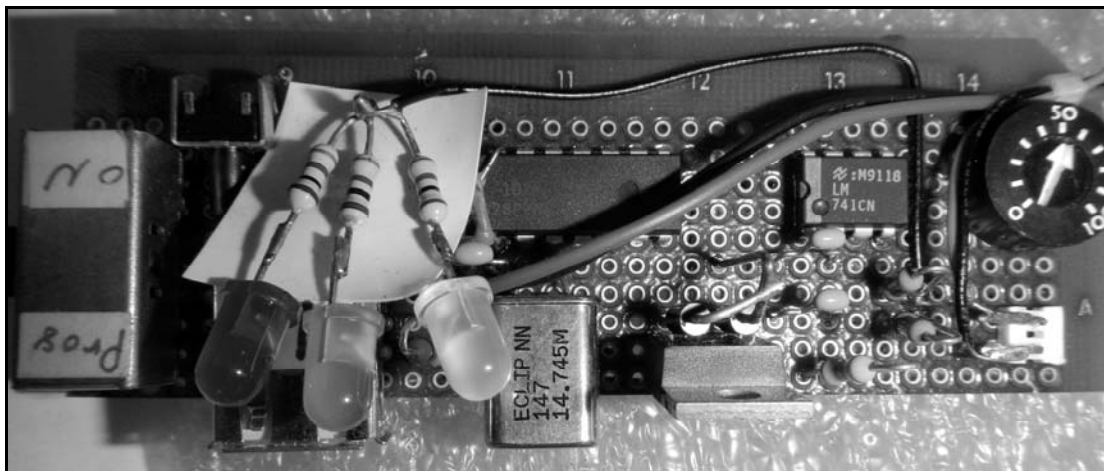

FIG. 16.—Printed circuit board assembly.

The primary component is the microcontroller, which has a built in CPU to carry out instructions, flash memory to retain programming and RAM to store collected data. The microcontroller integrated with additional external circuitry was required to perform the detection, recognition and tally of vehicles at Seascap (Fig. 17).

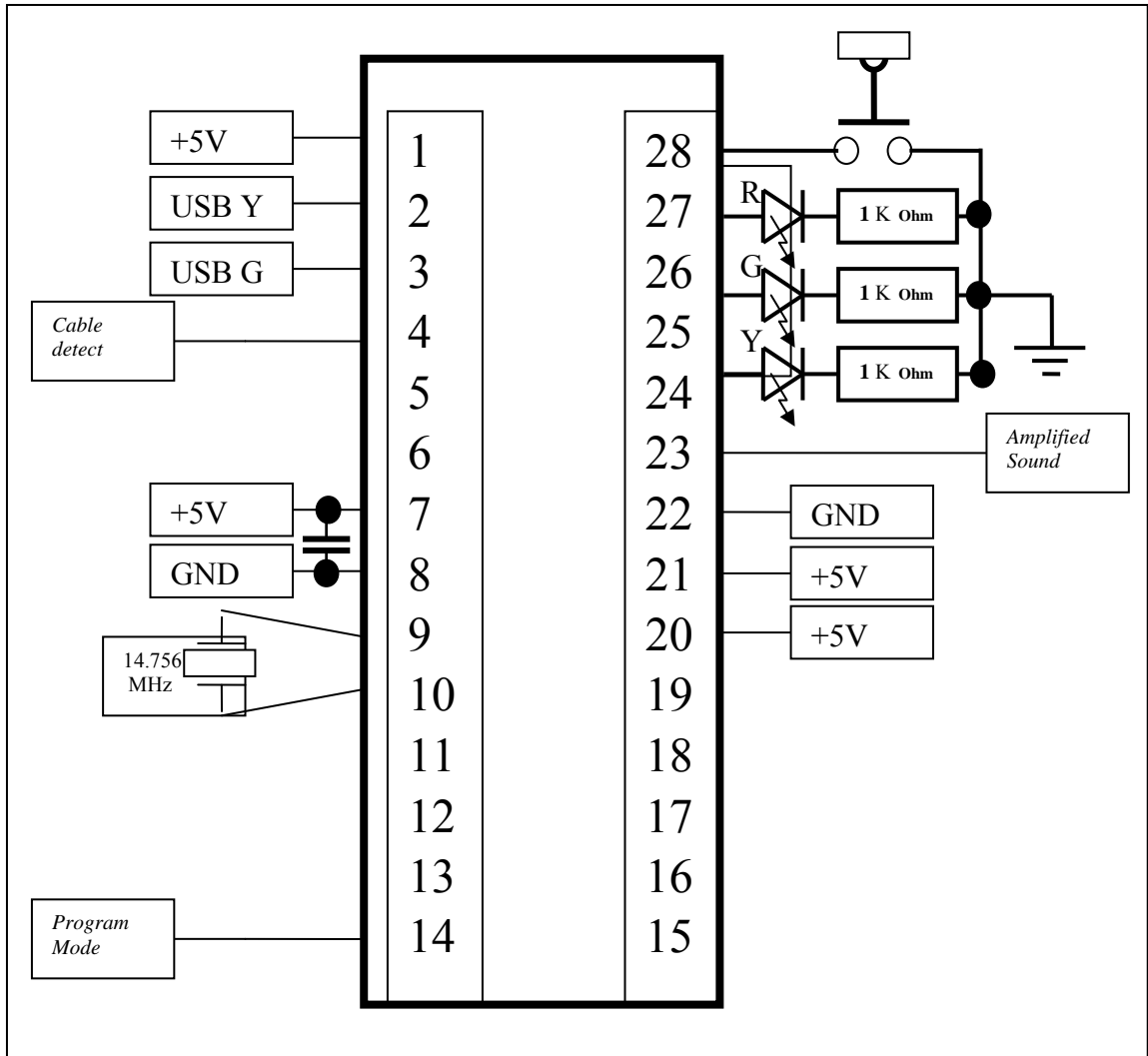

Fig. 17.—Car counter microprocessor

A power circuit was designed utilizing a fixed volt regulator (7805) producing a stable 5-volt power source (Fig. 18). The power supply circuit was designed to allow operation of the car counter while plugged into a USB power source or independently when decoupled, rendering stand-alone operations. In the field the power supplied to the regulator were multiple 1.5-volt AA batteries arranged in series in order to sustain prolonged operations.

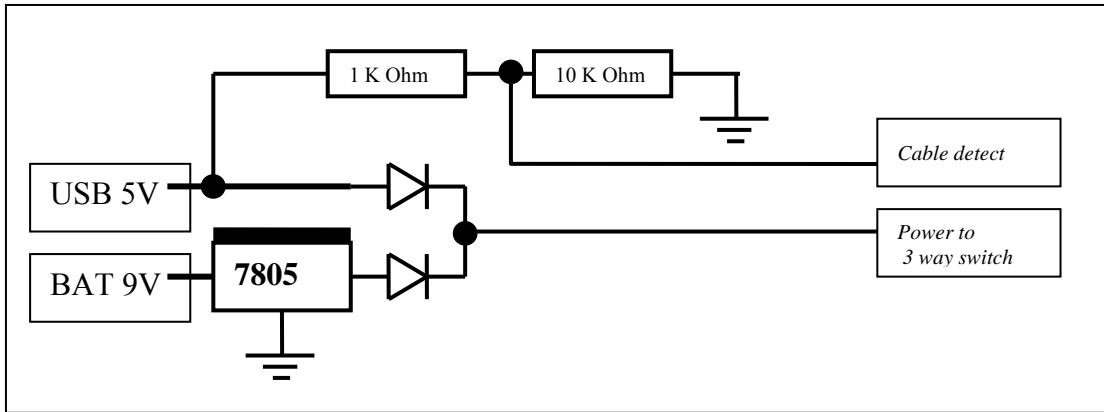

Fig. 18.—Power supply schematic.

Sound entering the car counter via the microphone required amplification. The unit also needed the ability to be tuned. An operational amplifier (LM 741) in parallel with a potentiometer (1 meg Ohm) on its inverting input was used to accomplish this (Fig. 19).

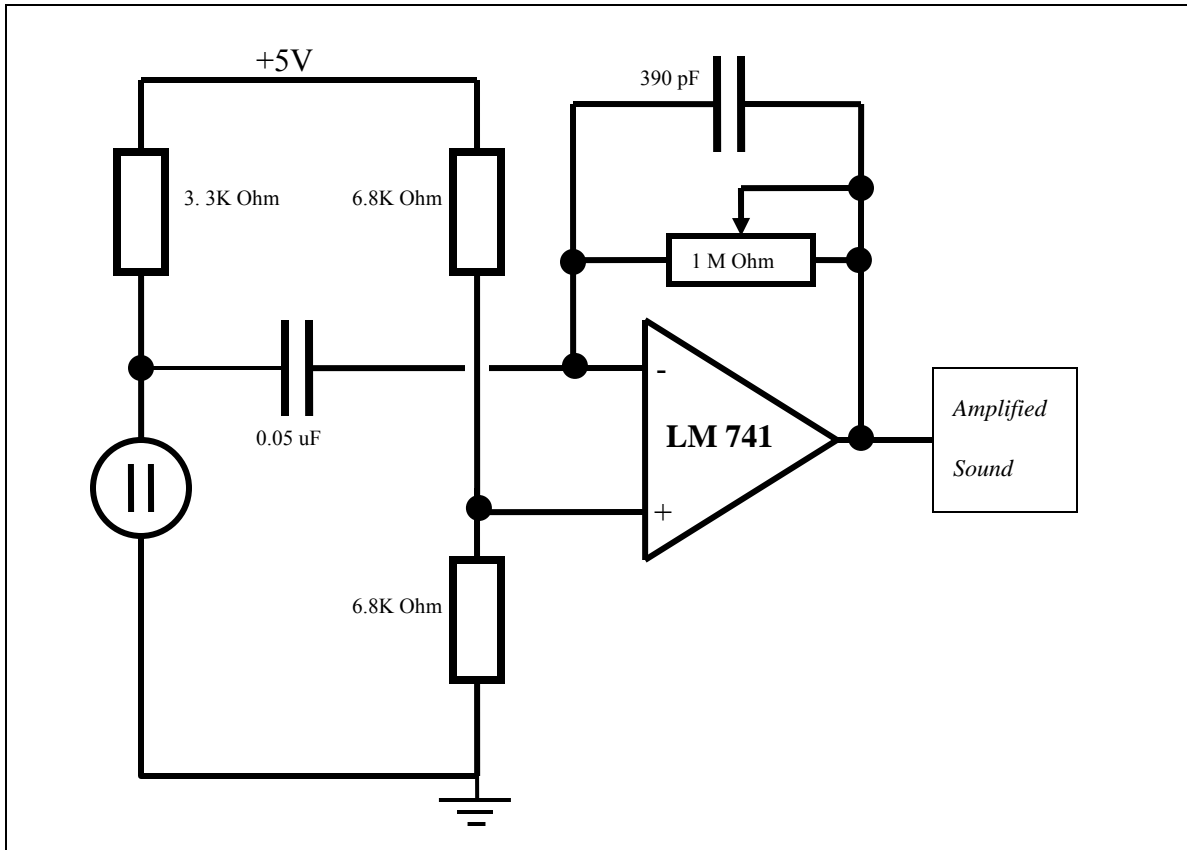

FIG. 19.—Operational Amplifier schematic.

Software operation

When connected to a laptop via the serial USB cable the program in flash can be updated via avrdude (Fig. 20). First, the 3-way switch has to be set to ‘pgm’. When this switch is set to ‘run’ the serial cable can be used to communicate, to the car counter program by means of a very simple command language. This interface allows the unit to dump sound monitoring logs, manually start and stop monitoring, change or readout detection parameters, set system time, program activation and deactivation times for automatic monitoring, save, readout or clear previously recorded traffic data in EEPROM.

In standalone mode, the system operates in a daily cycle reserving battery life so that it can collect a few days of data in any programmable time interval. Each day, at the programmed start time, the system wakes up and starts monitoring until a programmed stop time. These start/stop values are part of the settings programmed in EEPROM.

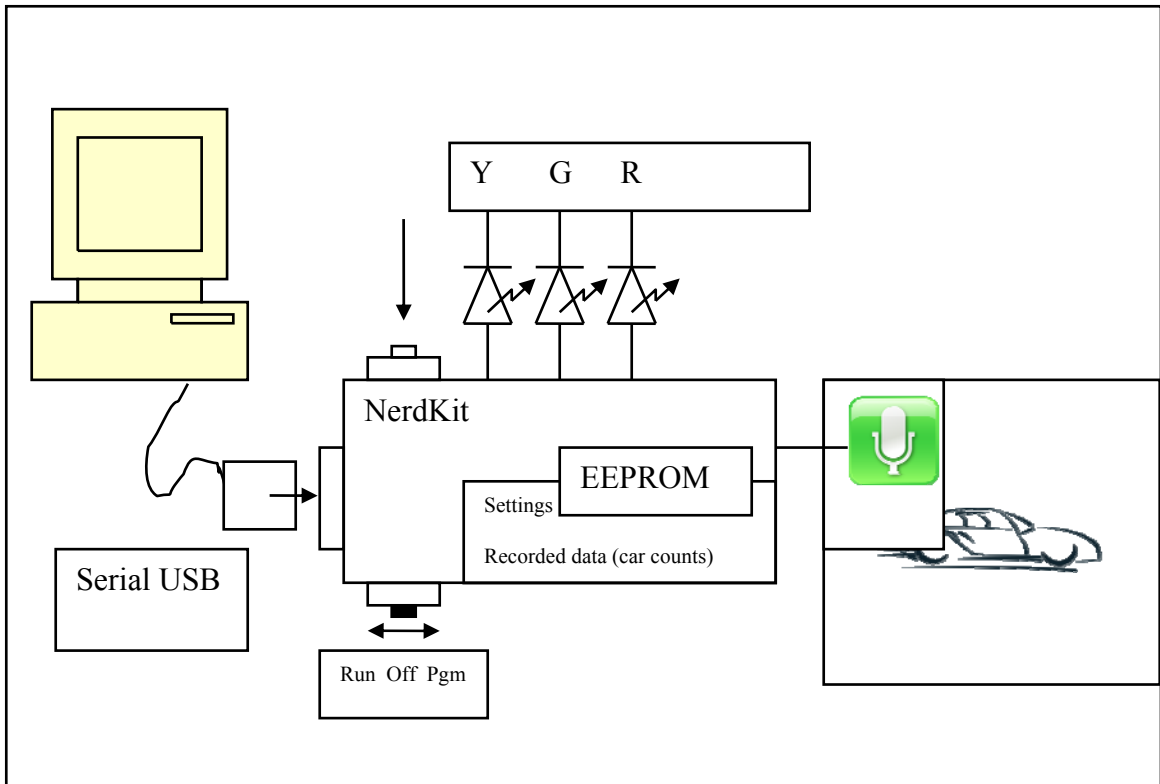

Fig. 20.—System interface.

When monitoring, the system updates a counter in memory for each detected car, the value of which is saved in a new EEPROM location at the end of each hour of monitoring. Using the serial USB command interface, the entire set of hourly values can

be read out after the system is retrieved from its monitoring location, and plotted off line (using a laptop) in a hourly traffic intensity histogram.

The push button and three LEDs are under software control. Behavior is as follows. A short button push manually toggles car monitoring, while pushing down for a few seconds displays the current value of the car count value in memory by blinking the red LED. The yellow LED shows if the system is currently listening to an elevated sound level and the green LED shows whether car level monitoring is currently active. The red LED blinks once after each detected car.

APPENDIX 6. MANUAL CAR TALLY SHEET

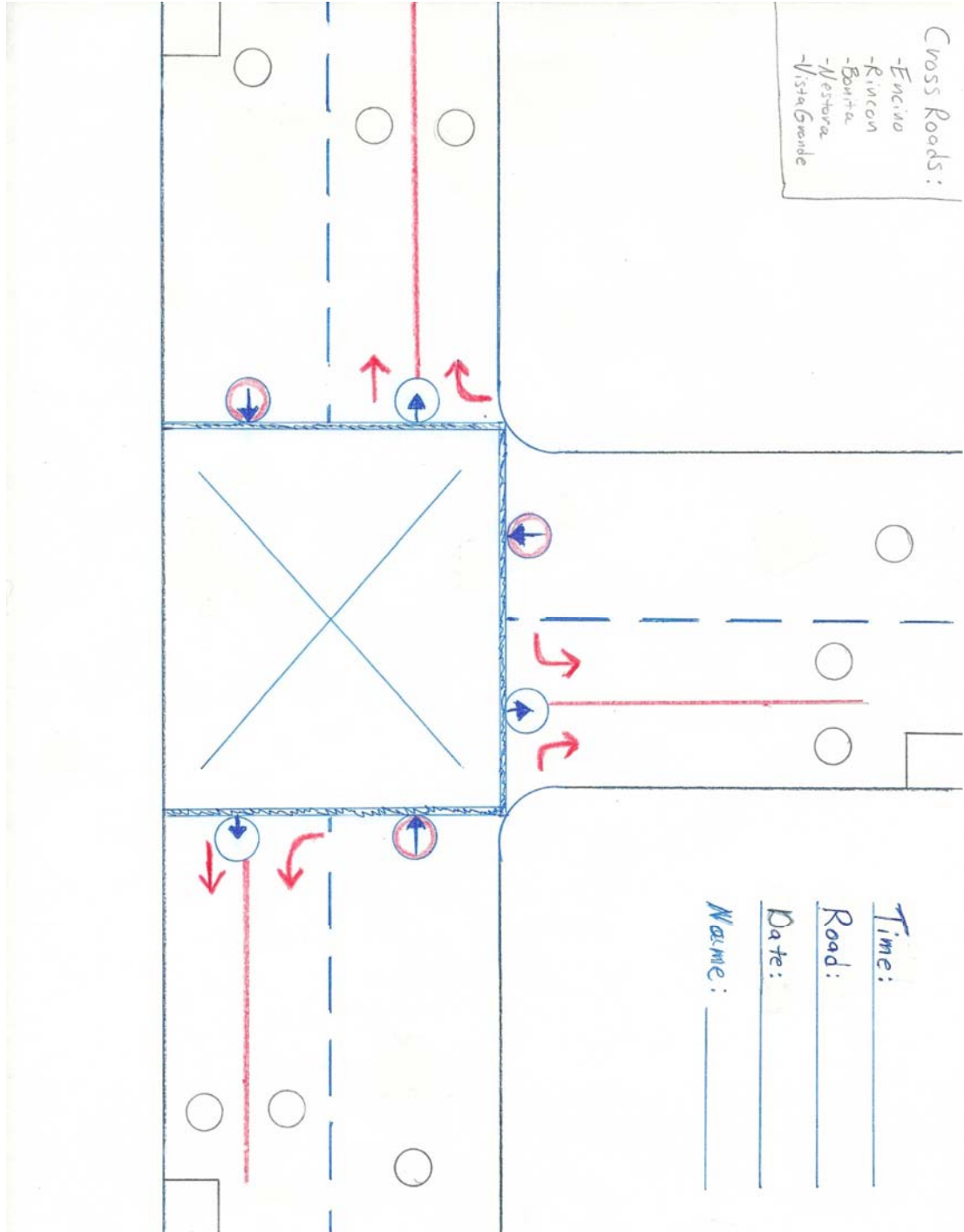

APPENDIX 7. AGGREGATED SALAMANDER PASSAGE TRACK (ASPT)TM

The Aggregated Salamander Passage Track (ASPT) is a safe passage system for small salamanders (SVL less than 7.5cm) with life history patterns of water/land. This design utilizes multiple railroad tracks running perpendicular to migration corridors across roads.

Each track is 11cm tall, 11cm wide (at base) and provides 5cm of clearance at its top, when stacked side by side (Fig. 21).

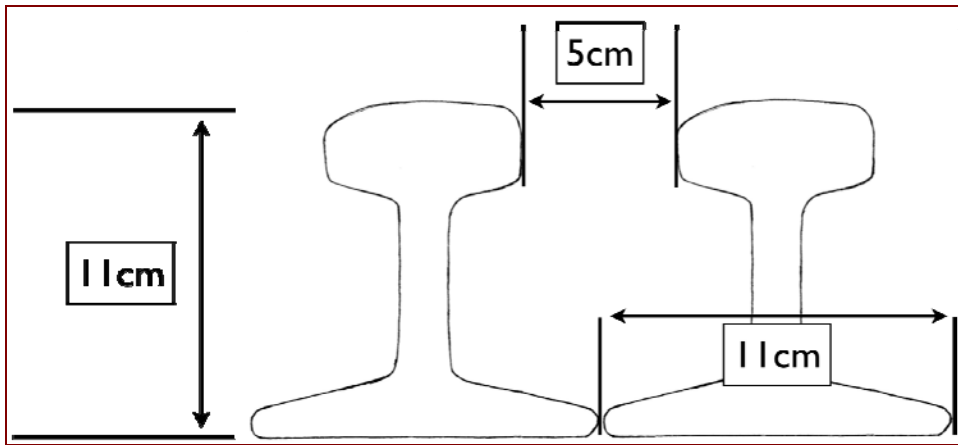

Fig. 21.—ASPT single track dimensions.

The ASPT system utilizes 8 railroad tracks butted side by side producing a single run just under 3feet (Fig. 22).

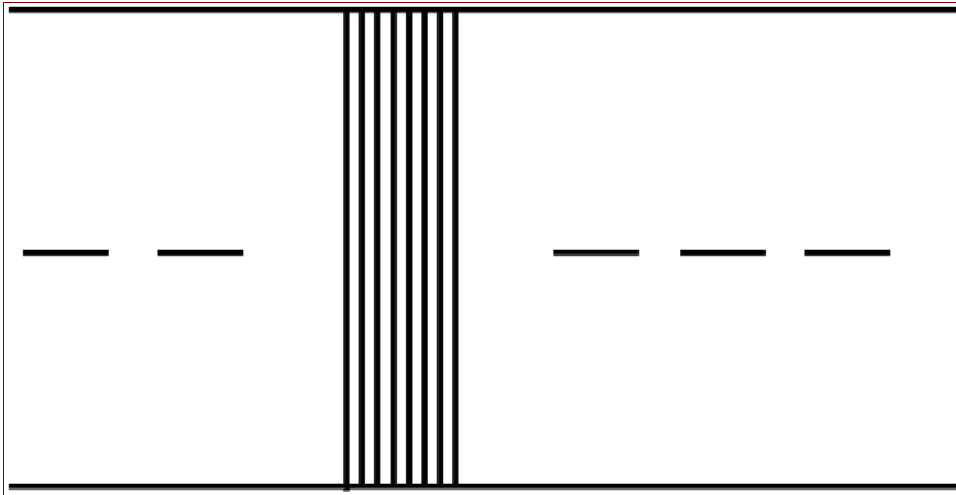

FIG. 22.—ASPT single run illustrated across road.

Each run is integrated into the road such that the tops of the rails are even with the road and the base is resting on a solid foundation (Fig. 23). Road edges should be reinforced.

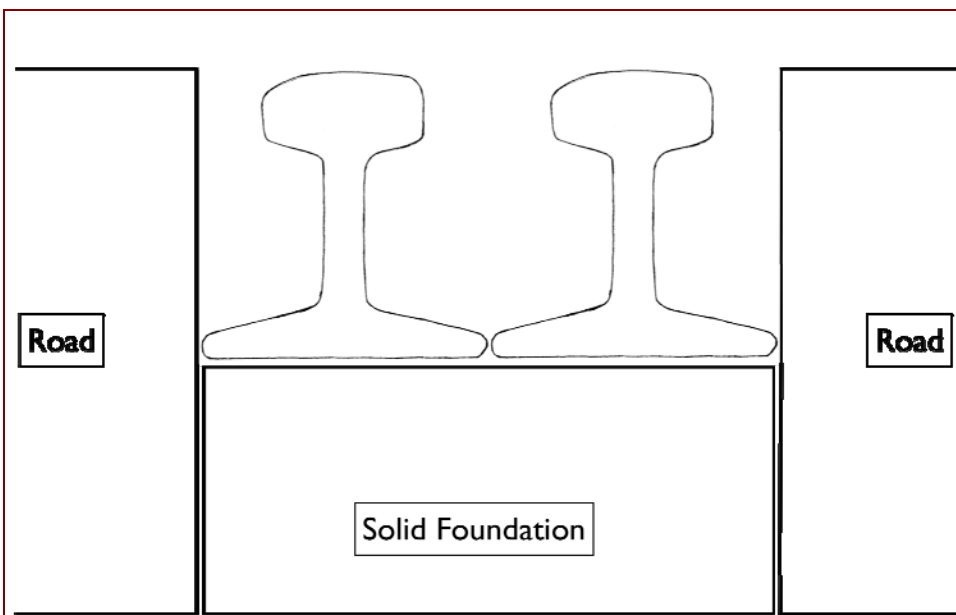

Fig. 23.—Integration into road.

The system as a whole maintains a minimum of 3 runs (Fig. 24). Permanent fencing is required that restricts the salamanders on the outside from climbing over, yet allows salamanders on the inside to escape.

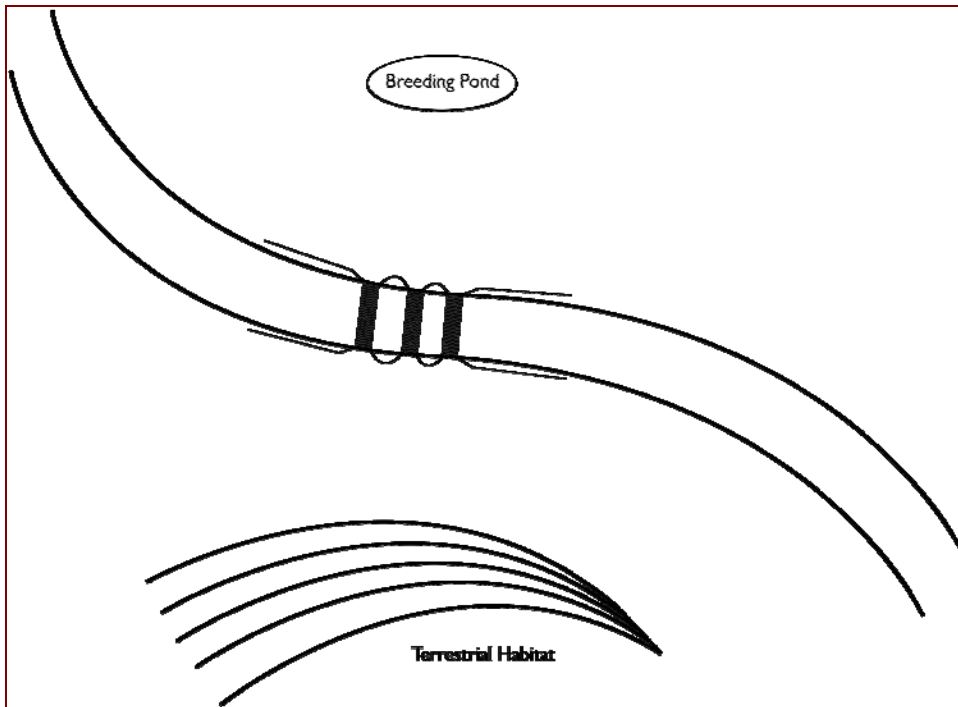

Fig. 24.—ASPT System across road.

The ASPT system allows salamanders to have an unobstructed view above their head and allows moisture to enter. If salamanders are able to climb over any one rail they have opportunity to fall into the next cavity. If by chance they climb onto the road they are able to reach the opposite side where are able to escape. This design eliminates the single small entrance and exit of a road tunnel. It also eliminates a single point source of food awaiting predators, much like road tunnels.

Maintenance would be required prior to the start of each migration season to clear dirt and debris. The top of each rail should be scored (if required) to meet traction

requirements for vehicles. Tops of rails should be painted white to make visible to oncoming traffic. Signs should be posted alerting drivers. Pedestrian access should be cautioned; signs warning of tripping hazard should be posted.



Save the Santa Cruz Long-toed Salamander!