

2007

Securing Wireless Networks from ARP Cache Poisoning

Roney Philip
San Jose State University

Follow this and additional works at: http://scholarworks.sjsu.edu/etd_projects



Part of the [Computer Sciences Commons](#)

Recommended Citation

Philip, Roney, "Securing Wireless Networks from ARP Cache Poisoning" (2007). *Master's Projects*. 131.
http://scholarworks.sjsu.edu/etd_projects/131

This Master's Project is brought to you for free and open access by the Master's Theses and Graduate Research at SJSU ScholarWorks. It has been accepted for inclusion in Master's Projects by an authorized administrator of SJSU ScholarWorks. For more information, please contact scholarworks@sjsu.edu.

Securing Wireless Networks from ARP Cache Poisoning

A Project

Presented to

The Faculty of the Department of Computer Science

San Jose State University

In partial Fulfillment

of the Requirements for the Degree

Master of Computer Science

By

Roney Philip

May 2007

APPROVED FOR THE DEPARTMENT OF COMPUTER SCIENCE

Dr. Mark Stamp

Dr. Robert Chun

Dr. Jon Pearce

APPROVED FOR THE UNIVERSITY

ABSTRACT

Securing Wireless Networks from ARP Cache Poisoning

by Roney Philip

Wireless networks have become an integral part of today's networks. The ease of deployment, low cost, mobility and high data rates have contributed significantly to their popularity. The medium of data transmission in wireless networks makes them inherently less secure than wired networks. For wireless networks to access the Internet they must be connected to a wired network via an Access Point or a wireless router. This has led wireless network equipment manufacturers to implement wireless Access Points and wireless routers with a built in switch for wired clients and a WiFi access point for wireless clients. The set up within the equipment is such that the wired and wireless networks are internally bridged together such that they are in a single Local Area Network (LAN). This mix of wired and wireless networks poses a new class of attacks on wired networks via insecure wireless LANs. One such class of attack is the Address Resolution Protocol (ARP) Cache Poisoning attack. Depending on the wireless LAN set-up, previously secure wired networks may become vulnerable to attacks from wireless clients in the same LAN as the wired client.

My project aims to develop a solution to prevent ARP Cache Poisoning attacks in a wireless Access Point-based network, involving wireless and wired clients. I have proposed a design to prevent ARP cache poisoning attacks and, as a proof-of-concept, have implemented the design in a Wireless router manufactured by Linksys.

ACKNOWLEDGEMENTS

I would like to thank Dr. Mark Stamp, for his guidance, inspiration and patience throughout the course of my project, without which this project would have been impossible.

I would also like to express my sincere gratitude to my family for the support and encouragement rendered to me to undertake this project. Above all, I am indebted to God for the strength and wisdom He's given me during this project.

TABLE OF CONTENTS

1. INTRODUCTION	1
2. BACKGROUND	3
2.1 ADDRESS RESOLUTION PROTOCOL (ARP).....	3
2.2 ARP CACHE POISONING	9
2.3 WIRELESS NETWORKS.....	11
2.4 ARP CACHE POISONING IN WIRELESS NETWORKS	14
2.5 PRIOR RESEARCH.....	19
3. DESIGN	21
3.1 DESIGN GOALS	21
3.2 THE DESIGN	22
3.3 ALGORITHM.....	28
4. IMPLEMENTATION	29
4.1 HARDWARE	30
4.2 OPENWRT FIRMWARE.....	32
4.3 CODE PLACEMENT.....	33
4.4 IMPLEMENTATION DETAILS	35
5. TEST CASES AND RESULTS	38
5.1 ATTACK SCENARIOS TESTED	39
5.2 IMPACT ON PERFORMANCE	44
6. CONCLUSIONS AND FUTURE WORK	46
REFERENCES	48

INDEX OF FIGURES

Figure 1: The architecture of the TCP/IP reference model.....	4
Figure 2: Operation of ARP when the command 'ftp 10.40.68.22' is typed.....	6
Figure 3: Format of an ARP message.....	7
Figure 4: ARP message in an Ethernet header.....	8
Figure 5: Host C performing the ARP poisoning attack on Host A and Host B.....	10
Figure 6: Man-in-the-middle attack.....	10
Figure 7: Infrastructure mode.....	12
Figure 8: Adhoc mode.....	13
Figure 9: General set-up of wireless network with the wired network.....	15
Figure 10: Wireless client attacking wired clients.....	16
Figure 11: Wireless client attacking a wired client and a wireless client.....	16
Figure 12: Attacking wireless clients.....	17
Figure 13: Attacking roaming wireless hosts.....	17
Figure 14: Combined home gateway device.....	19
Figure 15: Attacking two wired clients via a wireless client in a home deployment.....	19
Figure 16: Attacking a wired client and a wireless client in a home network.....	20
Figure 17: Timeline diagram of DHCP messages exchanged.....	23
Figure 18: Format of a DHCP message.....	24
Figure 19: WRT54GL wireless router.....	30
Figure 20: Internal diagram of the OpenWrt firmware.....	34
Figure 21: Structure of sk_buff.....	36
Figure 22: Attacking wired clients from wireless client.....	39
Figure 23: ARP cache of Host A before the attack.....	40
Figure 24: ARP cache of Host B before the attack.....	40
Figure 25: ARP cache of Host A after the attack.....	41
Figure 26: ARP cache of Host B after the attack.....	41
Figure 27: ARP cache of Host A when arp_patrol_agent() is enabled.....	42
Figure 28: ARP cache of Host B when arp_patrol_agent() is enabled.....	42
Figure 29: Attacking a wireless and a wired client.....	43
Figure 30: ARP cache of Host B before the attack.....	43

Figure 31: ARP cache of Host B after the attack.....44
Figure 32: ARP cache of Host B when arp_patrol_agent is enabled.....44
Figure 33: Round trip time measurement for ARP request-reply in ms.....45
Figure 34: Percentage overhead.....46

1. INTRODUCTION

Wireless networks have gained considerable momentum in businesses, government offices, hot spots and even buildings requiring high security. Wireless networks use radio waves to transmit data. Hence any device located within the range of the network and having a wireless network interface card can potentially read the data. In a wired network a machine needs to be physically connected to the network; such connection points are typically protected by physical security measures such as those associated with the perimeters of a building. However, with a wireless network, in many cases it is not possible to restrict the range of the radio waves to the exact perimeters of physical security. This makes wireless networks more vulnerable to attacks than wired networks. Various security schemes like Wired Equivalent Privacy (WEP) and Wi-Fi Protected Access (WPA) have been employed to encrypt the data transmitted within a wireless network. Even with these schemes in place, a class of attacks known as Address Resolution Protocol (ARP) Cache Poisoning is still achievable as this class of attack and the above-mentioned encryption schemes are in two different layers of the Transport Control Protocol/Internet Protocol (TCP/IP) network architecture model.

Wireless networks communicate to each other and the Internet via an Access Point (AP) or a wireless router. The AP needs to be connected to a backbone wired network in order to connect its wireless clients to the Internet. In order to achieve this setup the AP is connected to a switch, which serves wired clients as shown in Figure 9. This enables the wireless clients to access the Internet just like the wired clients connected to this switch. Many network equipment manufacturers also provide this setup within a single device by providing a built-in switch for wired clients, a built-in AP for wireless clients and a built-in router which is to be connected to a modem that connects to the Internet as shown in Figure 14. The AP is internally connected to the switch via a bridge. A bridge is a device that connects different network interfaces at the data link layer (Layer 2) of the Open Systems Interconnection (OSI) network architecture

model. The OSI model and its various layers are explained in Section 2. Here, the bridge forwards traffic from the wireless network to the wired network after converting the 802.11 wireless packets into 802.3 Ethernet packets and vice versa. Due to the presence of the bridge between the AP and the switch, all the clients connected to the switch and the AP are in a single Local Area Network (LAN). Hence, any broadcast packet sent from a wireless client will reach not only the wireless clients connected to the AP but also all the wired clients connected to the switch. This setup introduces a possible vulnerability in the wired network by exposing it to ARP Cache Poisoning attacks from the wireless clients.

ARP Cache Poisoning is a Layer 2 attack. In order for this attack to take place the attacker should have access to the LAN. The attacker should be connected directly or indirectly to any layer 2 device such as a switch, hub or bridge.

The aim of this project was to find a way to prevent ARP Cache Poisoning from wireless networks. According to Fleck, B. et al [1], the approaches to prevent ARP Cache Poisoning from wireless networks are the following:

- a. Redesigning the network architecture
- b. Redesigning or upgrading Access Point hardware and firmware
- c. Deploying VPN solutions

In this project I have taken the approach (b), of upgrading the Access Point firmware to prevent ARP cache poisoning from wireless networks.

The report is organized as follows:

- Section 2 gives the necessary background on the OSI and TCP/IP network architecture models, the ARP protocol and how an ARP cache poisoning attack is conducted. It also provides background on wireless networks and illustrates how ARP cache poisoning is achieved in wireless networks. This section also describes prior research done in solving ARP cache poisoning and some of their disadvantages.
- Section 3 defines the goals for our design, a description of the design itself and the components involved in the design.

- Section 4 explains the implementation details of our design.
- Section 5 presents the test cases emulated in a real life network with a Linksys WRT54GL wireless router and the results obtained with and without the design.
- Section 6 outlines the contributions, presents some limitations and suggests future work for this project.

2. BACKGROUND

2.1 Address Resolution Protocol (ARP)

The Open Systems Interconnection (OSI) model, the standard model of network architecture, contains seven layers, as shown in Figure 1 [15]. Today, most real world networks use the TCP/IP model of network architecture. Figure 1 places the OSI model and the TCP/IP model side-by-side to show how the different layers of the TCP/IP model fall within the layering conventions of the OSI model. The figure also places the different protocols in the TCP/IP model based on the layer in which they operate.

The layers are numbered 1-7 from the bottom up. For example, the physical layer is layer 1 and the Application layer is layer 7. In the Network layer or layer 3 of TCP/IP suite, a host is identified by its IP address, a 32-bit number. But the Medium Access Control (MAC) layer or layer 2 of the TCP/IP suite follows a different addressing scheme. An interface in the MAC layer is identified by a 48-bit MAC address.

When layer 3 receives a packet from the higher layers it checks the IP address of the destination machine. If the destination machine is in the same local network as that of the sending machine, the packet can be sent directly to the destination machine; else the IP packet has to be routed via a router. To send the packet directly to the destination machine, the network layer needs to

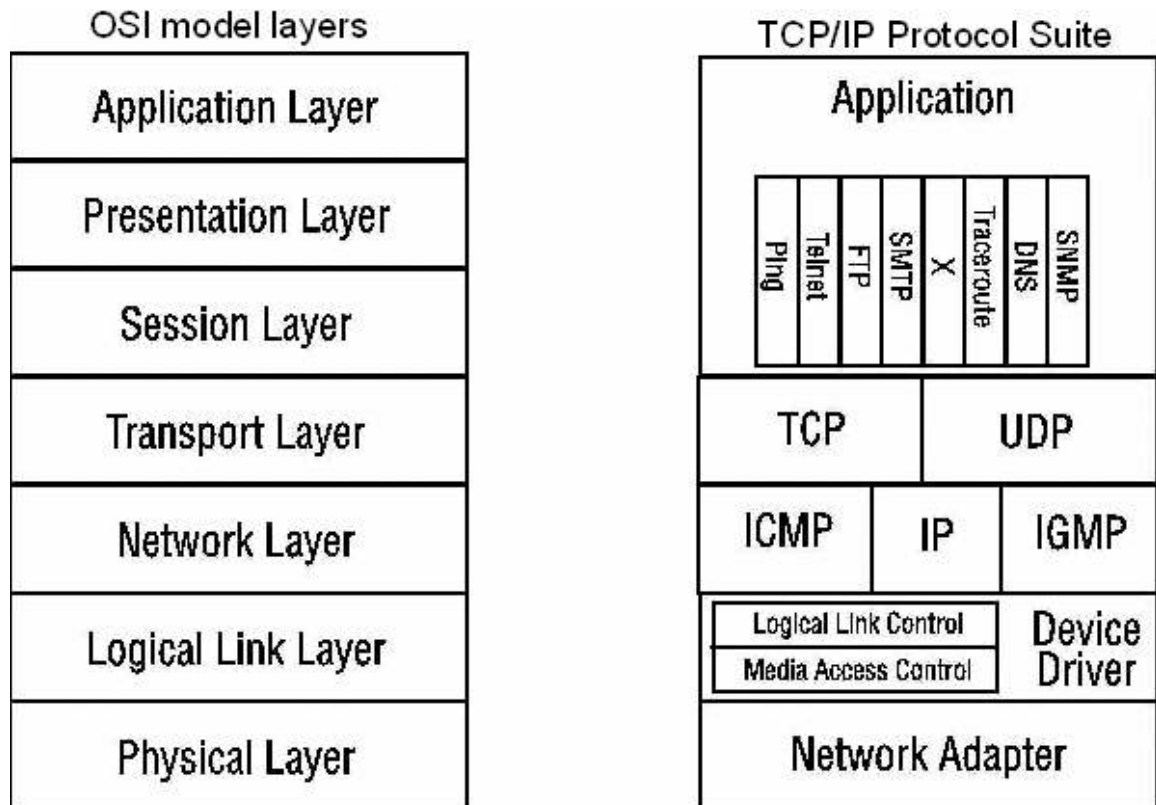

Figure 1: The architecture of the TCP/IP reference model [15]

know the MAC address of the destination machine. The network layer of the TCP/IP suite accomplishes this using the Address Resolution Protocol (ARP). ARP dynamically maps the 32-bit IP address of a machine to its 48-bit MAC address.

For example, suppose we type the command [13]

ftp 10.40.68.22

The following actions take place:

1. The FTP client asks the TCP layer to establish a connection with the IP address specified in the command.
2. TCP sends a connection request segment to the destination IP address in an IP datagram.
3. If the destination IP address is on a local network the IP address is converted into a 48-bit Ethernet address via ARP.

4. ARP broadcasts an ARP request in an Ethernet frame to all the hosts in its local network saying 'who has 10.40.68.22? tell 10.40.68.50'(Assuming 10.40.68.50 is the IP address of the requesting machine).
5. Every host that receives the ARP request checks if the target IP address belongs to it.
6. The host having IP address 10.40.68.22 will issue an ARP reply with its MAC address in that packet, saying, '10.40.68.22 is at 00:0f:d2:ce:43:12'.
7. Once the ARP reply is received by the sending machine, the IP datagram is sent to the destination machine.

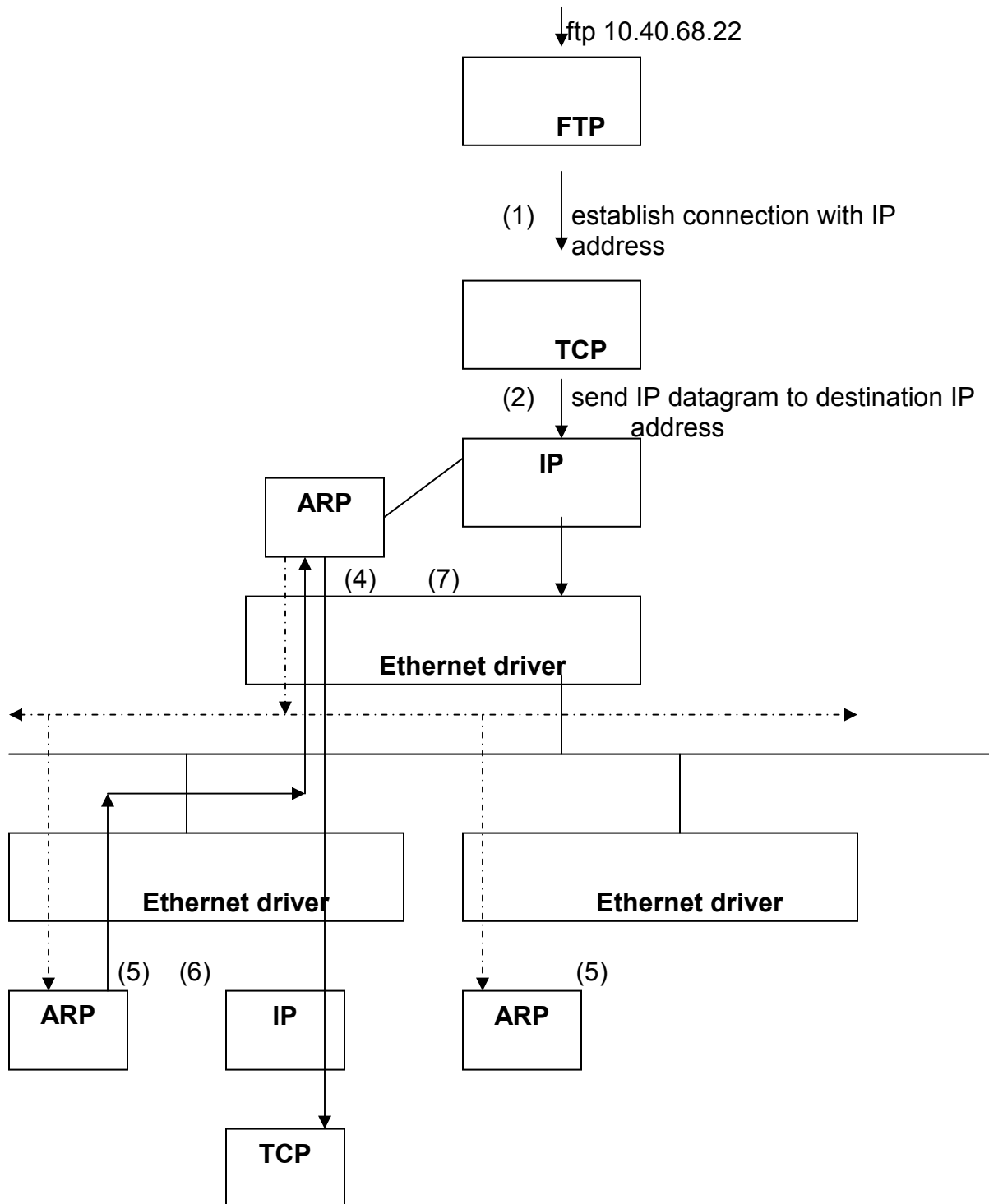

Figure 2: Operation of ARP when the command [ftp 10.40.68.22](ftp://10.40.68.22) is typed

2.1.1 ARP Messages

There are four types of messages in the ARP protocol:

- ARP Request

- ARP Reply
- RARP Request
- RARP Reply

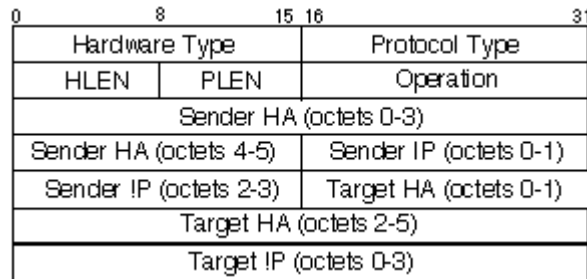

Figure 3: Format of an ARP message

The following are the fields of an ARP message:-

Hardware Type – Specifies what the underlying hardware is. Example, Ethernet

Protocol type- Specifies the type of protocol above this layer

HLEN – Specifies the length of the hardware address

PLEN – Specifies the length of the Protocol (Example IP) address

Operation – Specifies what type of ARP message it is.

1 - ARP Request

2 - ARP Reply

3 – RARP Request 4 – RARP Reply

Sender HA- Hardware Address/MAC address of the sending machine

Sender IP – IP address of the sending machine

Target IP – Target IP address of the destination machine

Target HA - Hardware Address/MAC address of the destination machine

- **ARP Request** – When a host sends an ARP request it fills in its MAC address, IP address, type of ARP message and the target IP address. The ARP request is broadcast to all the hosts in the same LAN as the sending host. The target HA is left blank for the host with the target IP address to fill in.

- **ARP Reply** – When a host receives an ARP request containing its own IP address as the target IP address, it fills in the target HA field with its MAC address. The host creates an ARP reply with the values of the sender and target fields in the ARP request reversed and the Operation field set to the opcode of the ARP reply. This packet is then sent only to the requesting machine.
- **RARP Request** – Reverse Address Resolution Protocol (RARP) is the reverse of ARP. A RARP request is sent when a machine wants to get the IP address that corresponds to its MAC address. RARP requests are broadcast in the LAN.
- **RARP Reply** – RARP Reply is sent by RARP servers. If the MAC address in the RARP request belongs to one of the clients served by the RARP server, a reply is sent with its corresponding IP address.

In this project we are not considering the RARP request and RARP reply as these messages are sent to get the IP address of the requesting machine. The ARP cache is not affected when RARP messages are sent or received. Hence the ARP Cache Poisoning is not possible with RARP messages. Also, most networks use the Dynamic Host Control Protocol (DHCP) or a static configuration for IP address assignment; hence the usage of RARP is not common.

ARP messages are encapsulated within an Ethernet header, as shown in the following figure before they are sent over the network.



Figure 4: ARP message in an Ethernet header

2.1.2 ARP cache

In order to reduce network traffic, the ARP layer in each host maintains a cache of the mapping of IP address to MAC address for previously resolved IP addresses [13]. This cache is maintained for a short period of time and the entry

is removed when its timeout expires; the timeout is renewed if it is accessed again. An entry in the ARP cache is created or updated in the following cases:-

- Just before a host sends an ARP reply to the machine which sent the ARP request, it will create an entry in its ARP cache for the mapping of the sender's IP address to the sender's MAC address.
- Whenever a host receives an ARP request from another host, if an entry corresponding to the IP address of the sending host exists in its ARP cache, the entry will be updated.

2.2 ARP Cache Poisoning

ARP Cache Poisoning is the technique by which an attacker maliciously modifies the mapping of an IP address to its corresponding MAC address in the ARP cache of another host. This is a man-in-the-middle (MiM) attack by which the attacker can divert the traffic passing between two machines to pass via him.

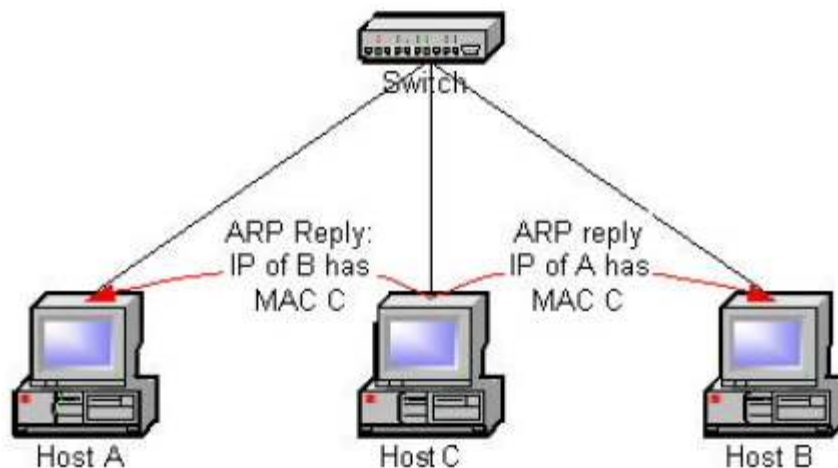

Figure 5: Host C performing the ARP poisoning attack on Host A and Host B

In Figure 5 the attacker is Host C. It executes the ARP Cache Poisoning attack by sending a spoofed ARP reply to Host A saying that 'IP address of Host B maps to MAC address of Host C' and a spoofed ARP reply to Host B saying that 'IP address of Host A maps to the MAC address of Host C'. ARP is a stateless protocol and replies are not checked against pending requests. Hence

Host A and Host B will update their ARP cache with the mapping received in the ARP replies.

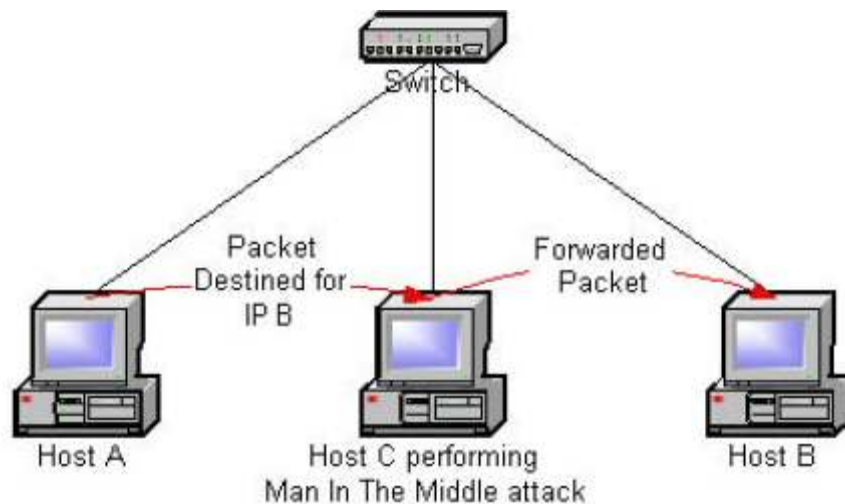

Figure 6: Man-in-the-middle attack

Once the ARP caches of Host A and Host B are poisoned, Host A will send all the traffic destined for Host B, to Host C. Similarly Host B will send all traffic destined for Host A, to Host C. Host C can now read all the traffic between Host A and Host B. If Host C forwards the packets, after reading them, to the actual destination machine, then Host A and Host B will not even detect that they are being attacked.

2.2.1 ARP Cache Poisoning Methods

2.2.1.1 Unsolicited response

- A spoofed ARP reply could be sent to any host and the receiving host will update its ARP cache [10]
- A spoofed ARP reply could also be broadcast to all hosts in the LAN, thus poisoning the ARP cache of all the hosts with just one message

2.2.1.2 Request

When a host receives an ARP request, the ARP layer in the host will update its ARP cache with the mapping stated in the source IP and source MAC address fields of the ARP request packet [10], even if the request was not for that host. Hence an attacker only needs to send a spoofed ARP request (inherently broadcasted) to poison the cache of all the hosts in a LAN.

2.2.1.3 Response to a request

A malicious host in a LAN, on receiving a legitimate ARP request, can send a spoofed ARP reply [10]. There could be a race condition between the spoofed ARP reply and the legitimate ARP reply in reaching the requesting host. The ARP cache will be updated with the last received ARP reply.

2.3 Wireless networks

Wireless networks or Wireless LANs (WLANs) are LANs in which hosts communicate via radio waves.

2.3.1 Modes of Wireless LANs

There are two modes of WLANs:-

- *Infrastructure mode* – In this type of WLAN, all the wireless clients communicate via a base station or an access point (AP). The access point acts as a connection to the wired network, which is the backbone for the WLAN [14].

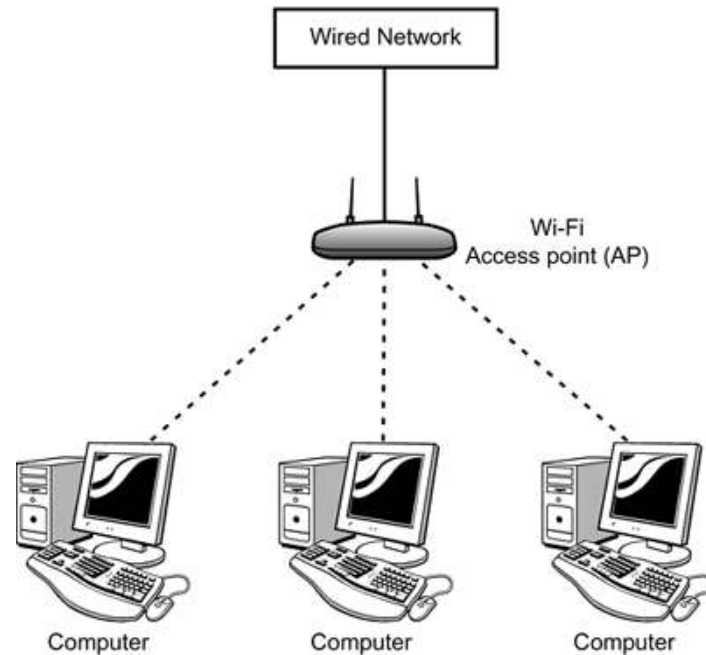

Figure 7: Infrastructure mode

- *Adhoc mode* - In this mode, the wireless clients can talk to each other on a peer-to-peer basis, without any central server [14].

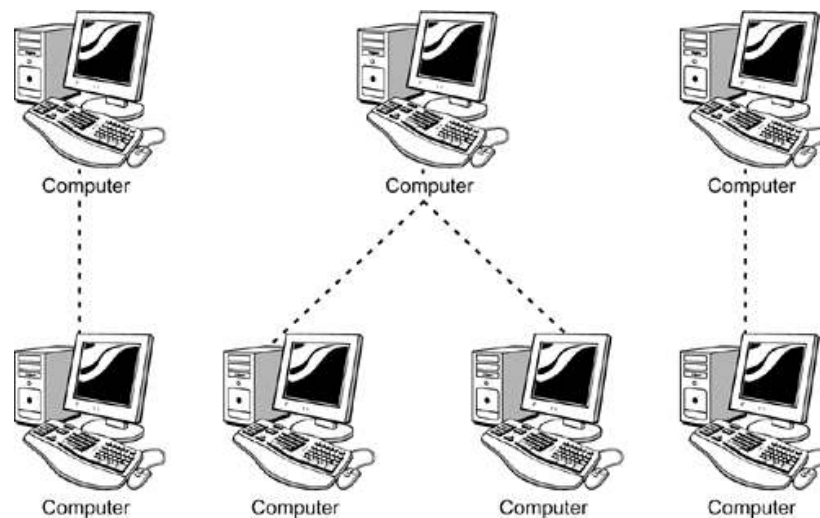

Figure 8: Adhoc mode

For this project we will only be considering the infrastructure mode of WLANs. The ARP Cache Poisoning problem is more of a threat when a wireless

client is trying to attack the wired clients through a wireless AP or a wireless router to which they are all connected. In adhoc mode, there is no wireless equipment to which the wireless clients and wired clients are commonly connected. Hence, the infrastructure mode of WLANs is where the problem exists.

2.3.2 Wireless Access Point

In the infrastructure mode, the wireless clients can communicate only through an access point. The access point decodes the radio waves received from the wireless clients and sends it to the Internet using an Ethernet connection. Similarly the data received from the wired network is encoded into radio waves and sent to the wireless clients.

A wireless client wanting to join a wireless network seeks for available Access Points [14]. Every Access Point continuously sends beacons to inform wireless stations of its existence. The Access Point sends a Service Set Identification (SSID) in the beacon, which distinguishes one access point from another. Once the wireless client has identified the access point it wants to join, it sends an association request to the Access Point. The wireless client and the AP go through a handshake process, which includes exchanging information regarding the network and authentication. The AP will authenticate the wireless client and intermediates network communication with the wireless client from that point onward.

Once the client is done using the wireless network, it has to disassociate from the AP. If the client does not disassociate and does not use the network for a specific period of time, then the association of that client will time out.

Functions of the Access Point:-

- Intermediates communication between two wireless stations that are communicating with each other
- Acts as a bridge between the 802.11 network and the wired network such as the 802.3 network.

2.4 ARP Cache Poisoning in Wireless Networks

ARP cache poisoning is an attack prevalent in LANs, i.e., all hosts connected to the same switch or hub as that of a malicious host are vulnerable to this attack. Access points act as hubs for wireless networks and act as bridges between wireless networks and wired networks. The general setup of a wireless network bridged to a wired LAN is as shown in Figure 9.

As in the setup in Figure 9, the wired clients are connected to the same switch as that of the Access point. Any message broadcast from wireless hosts A and C reaches the wired Host B. The broadcast domain of a network includes all the machines connected to a switch [1]. Here the AP is connected to the switch, hence all the wireless hosts associated with that AP belong to the broadcast domain of that switch. The wired clients connected directly to the

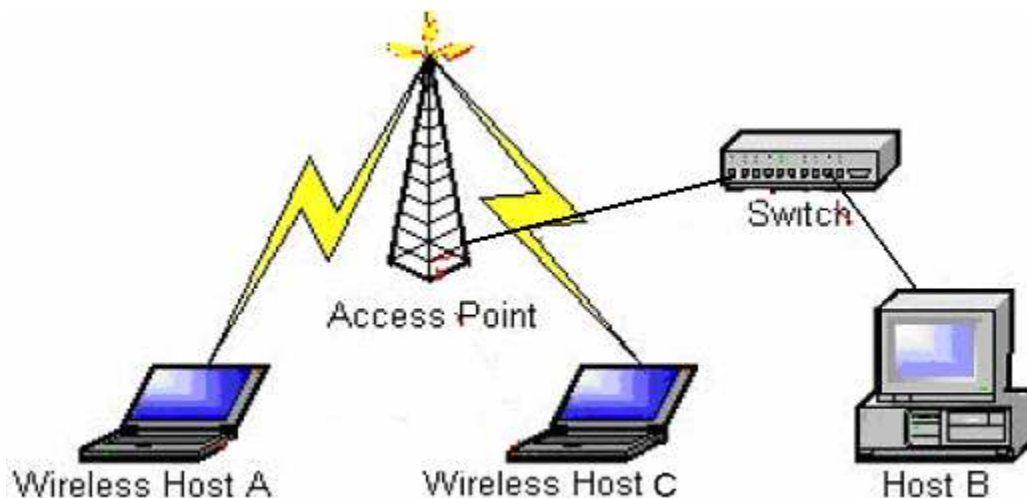

Figure 9: General set-up of wireless network with the wired network

switch also fall in the broadcast domain of that switch. ARP requests are broadcast in a LAN. Hence all the hosts in the broadcast domain receive the ARP requests. This in turn makes the wired hosts connected to the same switch as that of an AP vulnerable to an attack from wireless clients.

Generally, in hot spots like cafes, car dealerships etc., an Access Point will be provided to customers who have a wireless host so as to get connected to the wireless network. The general setup is such that the AP will be connected to a switch to which the café's wired hosts are also connected. The wired hosts could be transmitting confidential information among each other. This information can be easily read if a malicious wireless customer does a MiM attack using ARP Cache Poisoning.

The ARP cache poisoning attack can be performed even if the wireless clients are in a wireless network enabled with security features like Wired Equivalent Privacy (WEP) or Wi-Fi Protected Access (WPA). WEP and WPA encrypt the Layer 2 packets. ARP, being in the same layer as IP, is a Layer 3 protocol. Hence the poisoned ARP packets sent in a wireless network are sent within a WEP or WPA encrypted frame. The wireless clients that are doing the ARP cache poisoning attack have already joined the network and hence all packets sent from these wireless clients are encrypted. The Access Point will accept and forward these packets to the destination wireless machine because they are WEP or WPA encrypted with the initially assigned key. When the packet reaches the destination machine the frame is decrypted and the spoofed mapping is read from the ARP frame. The ARP cache is updated with the spoofed mapping, thus poisoning the ARP cache.

2.4.1 Attack Scenarios

2.4.1.1 Attacking wired clients using a wireless client

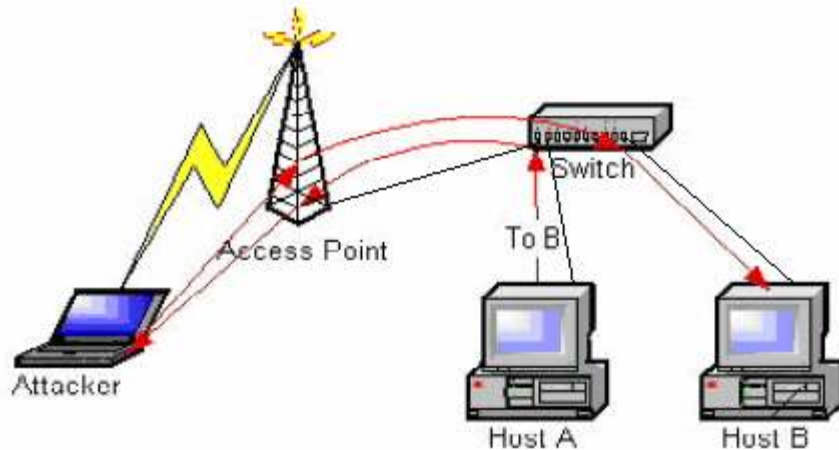

Figure 10: Wireless client attacking wired clients

In this scenario, a wireless client, the Attacker, sends a spoofed ARP packet to Host A stating that Host B's IP address is mapped to the Attacker's MAC address. Similarly the Attacker sends a spoofed ARP packet to Host B stating that Host A's IP address has the Attacker's MAC address. Thus the Attacker poisons the ARP caches of Hosts A and B, thereby directing the traffic between them to go through the Attacker [1].

2.4.1.2 *Attacking a wireless client and a wired client*

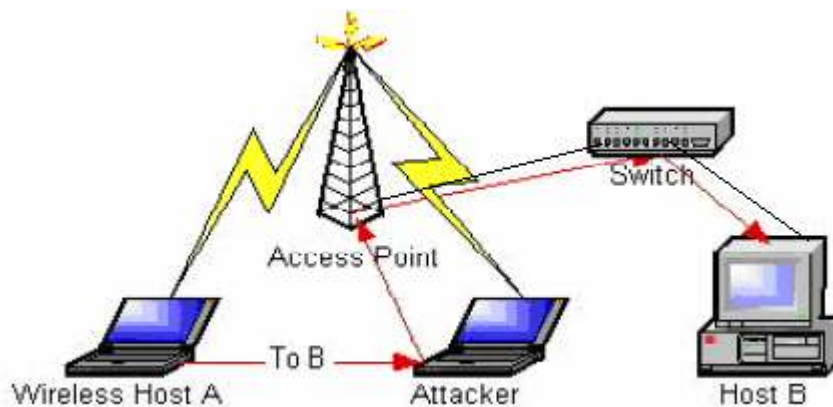

Figure 11: Wireless client attacking a wired client and a wireless client

In Figure 11, the Attacker sends spoofed ARP packets to wired Host B and Wireless Host A, thereby poisoning their ARP caches. Both the victims are

in the same broadcast domain as that of the Attacker, hence spoofed ARP packets will reach the victims [1].

2.4.1.3 Attacking wireless hosts

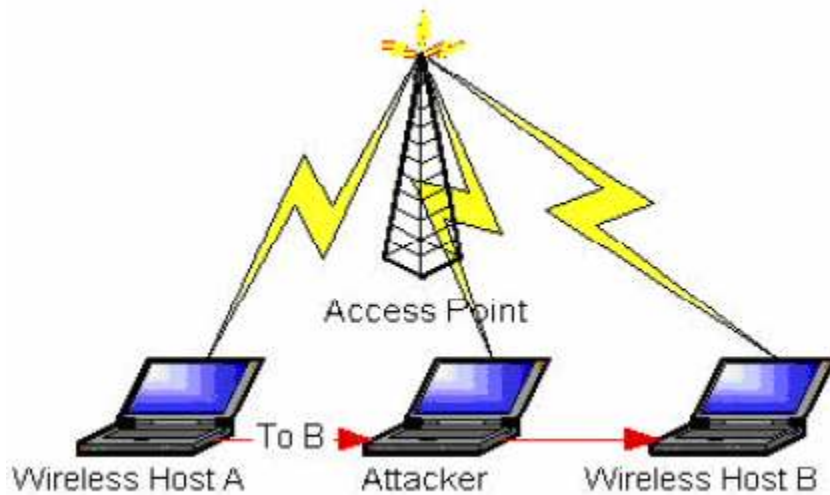

Figure 12: Attacking wireless clients

An Attacker can also attack two wireless hosts, which are in association with the same AP as the Attacker, as they are in the same broadcast domain [1].

2.4.1.4 Attacking roaming wireless hosts

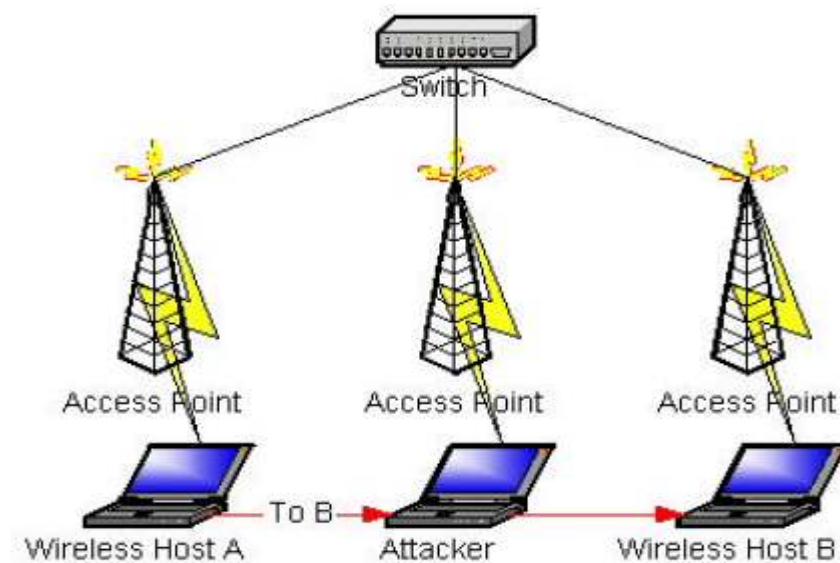

Figure 13: Attacking roaming wireless hosts

In Figure 13, there are multiple APs connected to the same switch. In 802.11b networks, to achieve roaming, the APs need to be connected to the same switch [1]. Due to this set up all the wireless hosts associated with these APs belong in the same broadcast domain. Hence any forged ARP packet sent from the Attacker can reach any wireless host connected to any of these APs.

2.4.1.5 Attacking home networks

Most vendors sell a combined router, switch and access point in one device as shown in Figure 14 [1]. In these devices the switch is for wired clients in the same LAN, the router is for the users to connect to their Internet Service Provider (ISP) and the AP is for wireless hosts in the LAN. Such a device satisfies the needs of a home network.

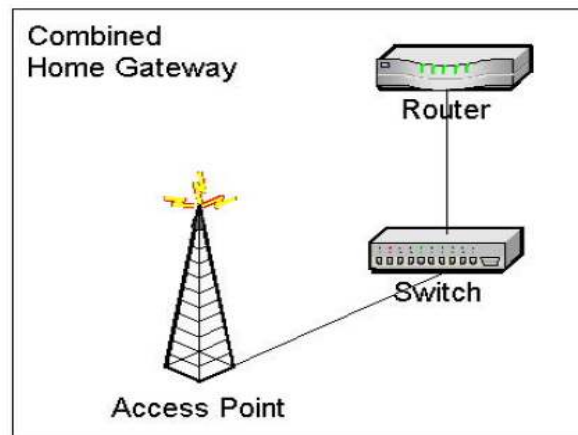

Figure 14: Combined home gateway device

In this combination device the AP is connected to the same switch as the wired clients. This results in the wired clients being vulnerable to an ARP Cache Poisoning attack from wireless clients. With this combined home gateway device, the above-mentioned attack scenarios from 2.4.1.1 – 2.4.1.2 are possible on home networks as well, as shown in Figure 15 and Figure 16 [1].

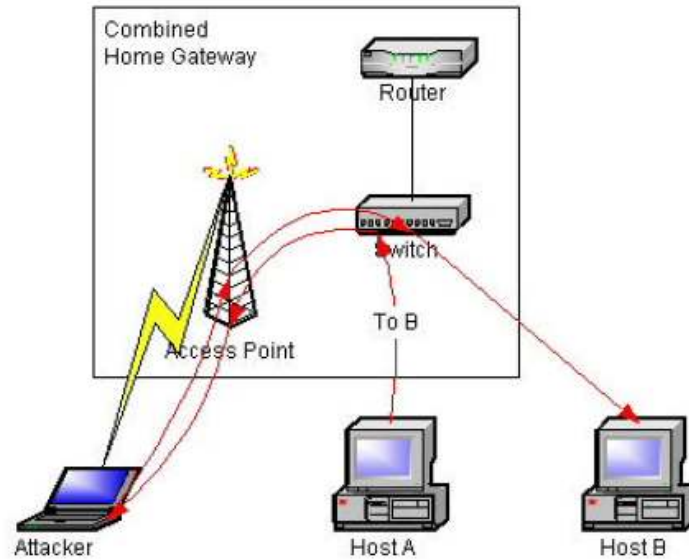

Figure 15: Attacking two wired clients via a wireless client in a home deployment

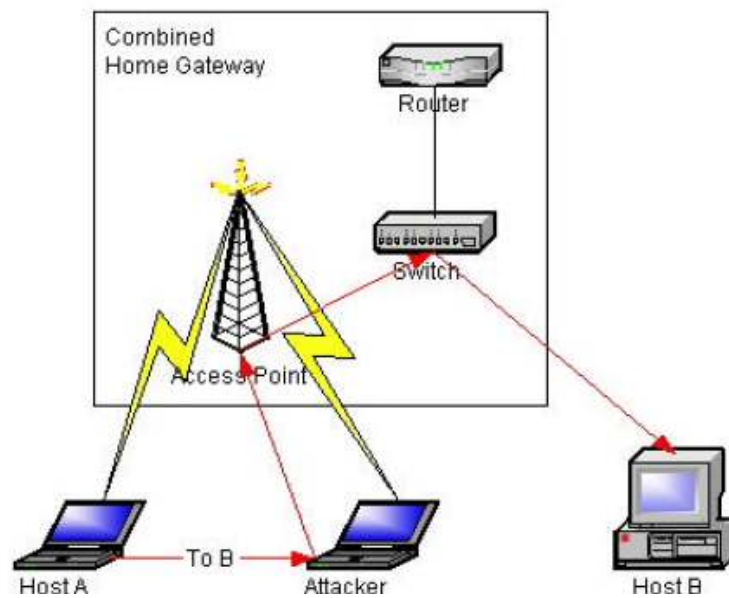

Figure 16: Attacking a wired client and a wireless client in a home network

2.5 Prior Research

There are several existing solutions to ARP Cache Poisoning; however, a detailed study shows that there are some disadvantages in the existing solutions.

Issac, B. et al [2] proposes 'Secure Unicast ARP by extending DHCP' to prevent ARP cache poisoning. In this solution, when Host A wants to communicate with Host B, it first sends a secure unicast ARP request packet to a DHCP+ server. A Secure Unicast ARP (S-UARP) request packet is a unicast ARP request packet sent to a DHCP+ server. The DHCP+ server is an enhanced DHCP server that understands Secure Unicast ARP packet formats. The DHCP+ server has information about the IP and MAC address mapping of all the hosts to which it has leased an IP address. Hence it responds with the MAC address mapped to the requested IP address in an encrypted format. It is a trusted party and the messages are encrypted before transmission, with a secret key that has been distributed to the client and the server by a Certification Authority. This makes sure that Host A will not get an ARP packet, which could cause poisoning. The drawback of this solution is that it requires modification to the ARP protocol, which means that all the Hosts in a LAN that want to prevent ARP Cache poisoning would have to modify their kernels to reflect the modified ARP protocol. It would also require a DHCP+ server, which would understand the secure unicast ARP packet and respond to it. Another modification that would be required is to the DHCP relay agent, as it has to be able to identify an S-UARP packet and forward it to the DHCP+ server.

Brushi et al [9] has proposed a Secure ARP (S-ARP), which uses asymmetric key cryptography to authenticate the hosts in a LAN. A Certification Authority assigns a private/public key pair to every host in the LAN. Each ARP packet sent from a host is signed with the host's private key. The receiving host verifies the signature of the ARP packet using the sending host's public key. To include the signature of the sending host in the ARP packet, an additional header is inserted at the end of the standard ARP protocol header. The solution in [9] also requires modification to the ARP protocol as the sender needs to sign each ARP message with his private key and the receiving host needs to verify the signature with the sender's public key. The author mentions in [9] that to get the entire LAN completely secure, all the hosts should be S-ARP enabled. S-ARP also introduces additional overhead and time for signature and verification by the

sender and the receiver respectively, for each ARP message. The other issue with this solution is that this is not a feasible approach for a wireless network environment like a hotspot, where the wireless clients entering the network are random and short-time users who cannot be expected to have S-ARP enabled.

Tripunithara, et al proposed a Middleware approach to prevent ARP cache poisoning in [10]. This approach maintains a 'requested' queue and a 'responded' queue in each host. If the host has sent an ARP request, it will be entered in the 'requested' queue and when the corresponding reply is received, it is entered in the 'responded' queue. Hence, whenever an ARP response is received, it is allowed to update the ARP cache only if there is a corresponding request in its request queue. The solution prevents the ARP Cache Poisoning attacks, but each and every host in the LAN has to be modified. The scale of deployment is very high.

3. DESIGN

3.1 Design goals

3.1.1 Protocol should remain unmodified

One of the major design goals for my project was that the ARP protocol itself should not require any modification. ARP protocol, as part of the TCP/IP suite, is a very popularly used protocol for mapping a host's IP address to its MAC address. The TCP/IP suite is widely deployed. Hence any protocol changes would require modification in all the hosts that need to use the protocol. In our design only the access point needs to be modified, hence the scale of deployment is much less compared to having to deploy the modification in all the hosts in a LAN.

3.1.2 Transparent to the users

The other design goal was to ensure that the security added to this protocol would be transparent to the users. For example, the user would not have to create any password or key to enable security from these attacks. By our design

the wireless clients just need to send ARP packets to the Access Point in the usual manner and it is the responsibility of the Access Point to monitor the packets for ARP Cache Poisoning attacks and make sure that the wireless clients are secure.

3.1.3 Minimal overhead when sending and receiving ARP packets

One of the other design goals was to make sure that there is minimal overhead in terms of expensive operations, associated with sending and receiving an ARP packet. For example, the sending host should not have to sign each ARP packet and the receiving host should not have to verify each ARP packet received using the public key of the sending host. These expensive operations would result in increasing the round-trip time of an ARP response being received, which ultimately affects the round trip time of the upper layer protocols.

3.2 The Design

3.2.1 Wireless clients and DHCP

In order for a wireless client to communicate via the wireless card, it has to associate with an Access Point. Once the wireless client associates with the Access Point, it has to get an IP address in order for it to connect to clients outside its LAN or to the Internet. In most networks today, the wireless client gets an IP address for itself from a DHCP (Dynamic Host Control Protocol) server. This is accomplished by sending a DHCP request; the DHCP protocol is explained in the next section.

3.2.2 DHCP Protocol

The DHCP protocol is a way of providing host-specific configuration parameters as well as providing network/IP addresses to the hosts from a DHCP server.

For the rest of our discussion we are only interested in the function of DHCP in providing IP addresses to the hosts. Figure 17 shows the timeline diagram of

messages exchanged when a host tries to get an IP address from a DHCP server. There could be multiple DHCP servers in the same LAN as that of the client. The client first broadcasts a DHCP DISCOVER message to locate the

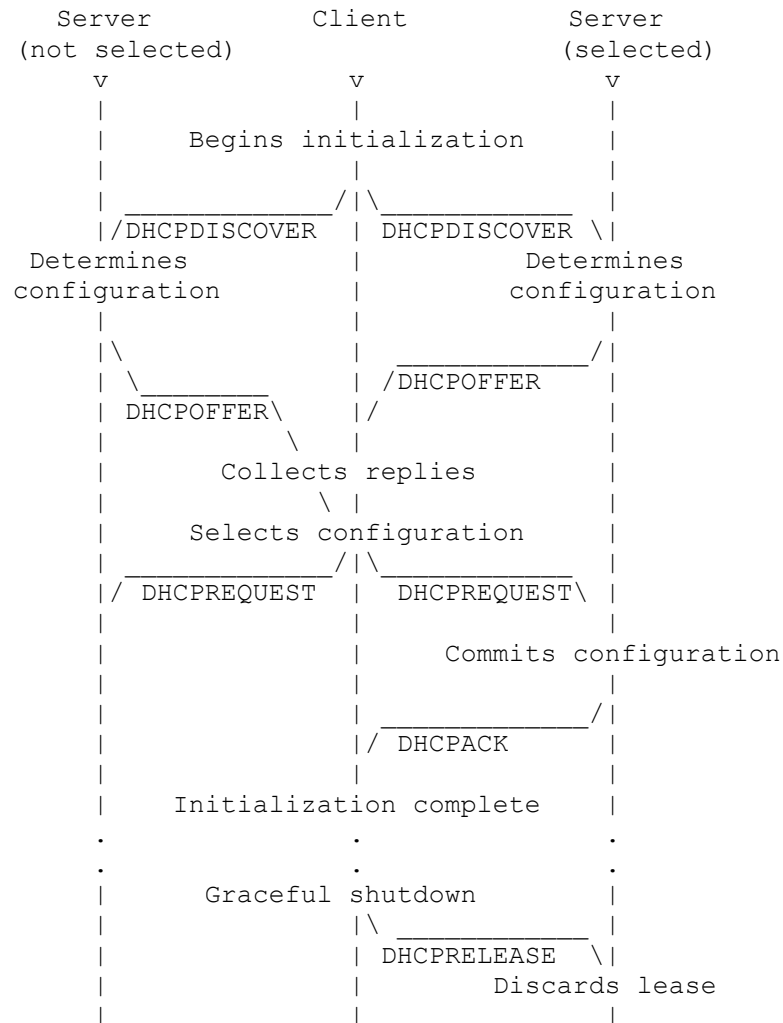

Figure 17: Timeline diagram of DHCP messages exchanged

available DHCP servers. All the DHCP servers that received the message will send DHCP OFFER messages with the configuration parameters they can offer to the host. The client then selects the configuration provided by one of the DHCP servers and sends a DHCP REQUEST message to all the servers indicating which DHCP server it has selected and also requesting the configuration parameters the selected DHCP server had offered. The selected DHCP server will lease that IP address to the requesting client and will send a

DHCP ACK message as a confirmation to the client. The IP address given to the client will not be given to any other host till the lease period is over.

The format of a DHCP message is as shown in Figure 18.

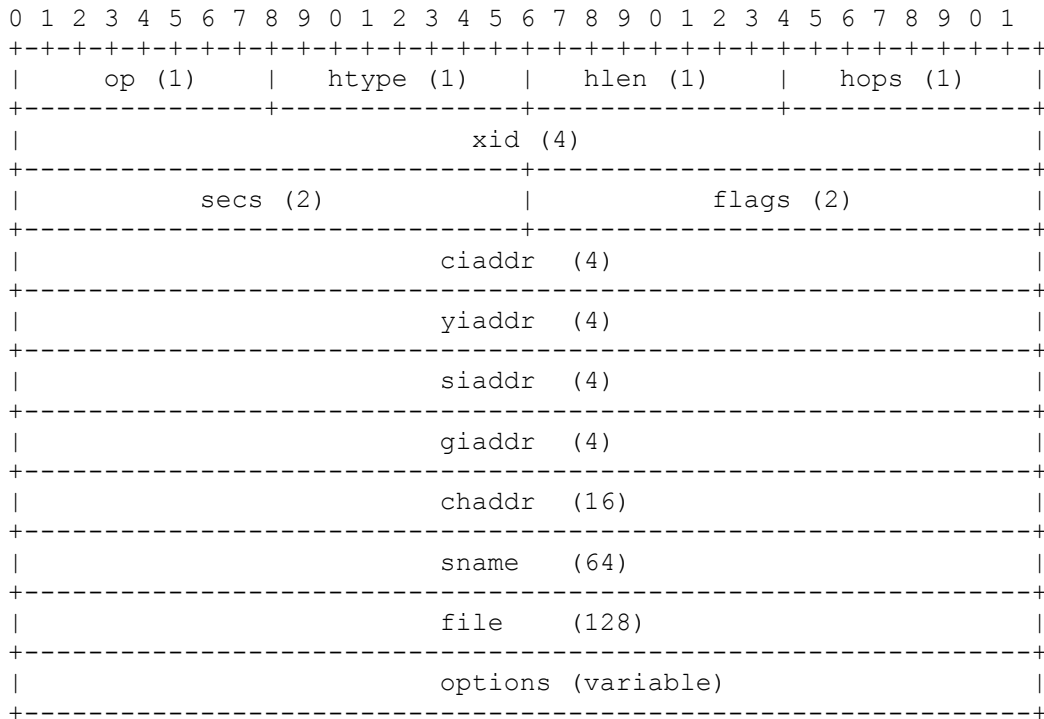

Figure 18: Format of a DHCP message

The fields required for the rest of our discussion are explained below:

Fields	Description
opcode	Message op code/ message type 1= BOOTREQUEST, 2= BOOTREPLY
yiaddr	'your' (requesting client's) IP address, the IP address assigned by the DHCP server to the client
giaddr	Relay agent IP address
chaddr	client hardware address

The format of the DHCP message remains the same for all the message types discussed above. But with each iteration the fields in the DHCP message get filled progressively. The 'opcode' indicates the type of DHCP message. During the DHCP DISCOVER – DHCP REQUEST message iterations the 'yiaddr' field is not filled. In the DHCP ACK message the IP address assigned to the client is put in this field. In the DHCP ACK message all the fields of the DHCP message are filled. The 'giaddr' is the default gateway address, to which the client sends packets destined for machines outside its LAN. The 'chaddr' field contains the MAC address of the requesting client machine.

- As the DHCP server and the DHCP messages contain the original IP address and MAC address of all the DHCP-enabled machines in a LAN, the Access Point can get the IP-to-MAC address mapping directly from the DHCP server or build up the mapping by monitoring DHCP messages. It can use this information to verify future ARP packets that are passing through it. This leads to the following alternatives: Design using the DHCP leases file
- Design using the DHCP ACK message

3.2.3 Design using the DHCP leases file

In most Access Points the DHCP Server exists within the Access Point itself. In that case the DHCP server will store all the IP addresses that it has leased out within that network along with their MAC addresses, retrieved from the DHCP messages, in the dhcp.leases file. This file will include all the wired clients connected to the switch within the Access Point and all the wireless clients associated with the Access Point. Whenever the Access Point sees an ARP request or reply, it can check the dhcp.leases file to verify whether the mapping in the ARP request/reply corresponds to the one in the file. If the mapping is not valid, the ARP request/reply packet can be choked. This prevents the ARP request/reply from poisoning the ARP cache of all the hosts connected to the Access Point as well as preventing the spoofed ARP packet from reaching the wired network.

3.2.4 Design using the DHCP ACK message

In a wireless network, since all the wireless clients can only communicate through the Access Point, every packet generated by or destined for a wireless client first reaches the Access Point. Hence, when a wireless client requests an IP address from the DHCP server, the DHCP messages are first received by the Access Point. The Access Point creates a mapping table, which stores the mapping of IP addresses to MAC addresses. The DHCP ACK message contains the client's MAC address and IP address. Every packet that reaches the Access Point should be scanned for a DHCP ACK message. Whenever a DHCP ACK message is encountered the IP address to MAC address mapping should be retrieved and stored in a mapping table created by the Access Point to store IP address to MAC address mappings. Since all the wireless clients registered with the Access Point have to get an IP address using the DHCP protocol, the mapping table will contain the correct mapping of all the wireless clients that communicate through this Access Point. Now, whenever the Access Point sees an ARP request or reply, it can use its mapping table to verify whether the mapping in the ARP request/reply is valid. If the mapping is not valid, the ARP request/reply packet can be choked. This prevents the ARP request/reply from poisoning the ARP cache of all the hosts connected to the Access Point as well as preventing the spoofed ARP packet from reaching the wired network.

3.2.5 Components of the system

3.2.5.1 *Mapping table*

The Access Point creates a hash table with IP address as the key and a structure containing the MAC address and the time of expiry (the time of expiry is calculated by retrieving the lease time and calculating the Access Point's time at the end of the lease time) as the value. Keeping the IP address as the key ensures that there are no duplicate IP addresses and each IP address maps to only one MAC address. Whenever an attacker spoofs an ARP message, he will be mapping a victim's IP address to his MAC address. Since an entry already exists in the mapping table containing the victim's IP address mapped to the

victim's MAC address, this message will be detected as an ARP poisoning packet.

This mapping table can be derived from the dhcp.leases file in an Access Point with a DHCP server running within it.

3.2.5.2 DHCP Agent

The DHCP agent scans all the incoming traffic, searching for a DHCP ACK message. Whenever the DHCP ACK message is encountered, the DHCP Agent will retrieve the values of the fields 'yiaddr' and 'chaddr' and store them as a new entry or overwrite the IP address and MAC address columns of an existing entry in the mapping table. There are two ways by which the mapping table is updated:

Case 1: New entry in the mapping table

A new entry is created in the mapping table when the DHCP server is assigning an IP address to the requesting client for the first time.

Case 2: Overwrite an existing entry

This happens when the DHCP server is extending the lease of an IP address previously assigned to the requesting client.

If the DHCP server exists within the Access Point, the DHCP server does the dhcp agent's work and the mappings are stored in the dhcp.leases file.

3.2.5.3 ARP Patrol Agent

The ARP Patrol Agent monitors all incoming traffic, looking for ARP messages. Irrespective of whether the ARP message is a request or reply, the mapping of the source IP to source MAC address is verified with the entries in the mapping table or the dhcp.leases file. We only check the source IP and the source MAC address mapping because, whether it's an ARP reply or request, the attacker is trying to spoof the source addresses since the receiving machine updates its ARP cache using the values in the source address fields. If the mapping is not valid, the ARP packet is choked.

3.3 Algorithm

3.3.1 DHCP agent algorithm

The algorithm for the DHCP agent is as follows:

Whenever a DHCP frame is received:

If the field, 'Message type' in the DHCP packet is Boot reply

 If the 'DHCP Message Type' is DHCP ACK

 Retrieve the IP address from the field 'yiaddr' and search
 for it in the mapping table

 If the yiaddr does not exist,

 Add it as a new entry into the mapping table.

 Retrieve the MAC address from the field 'chaddr'
 and add it as a value corresponding to the previously
 entered key.

 Else,

 Retrieve the MAC address from the field 'chaddr'
 and update the value corresponding to the retrieved
 key

 Else,

 Do nothing

Else,

 Do nothing

3.3.2 ARP Patrol agent algorithm

The algorithm for the ARP Patrol agent is as follows

When an ARP frame is received:

If source IP address in the packet is an entry in the DHCP hash table or
dhcp.leases file and the expiry time has not passed

```
If the MAC address corresponding to the IP address in the
hash table or dhcp.leases file is the same as the source MAC
address in the packet
    Accept the packet
Else,
    Drop the packet (Do not let the packet be sent to the
    destination machine)
Else,
    If the expiry time has passed
        Remove the entry in the mapping table and drop the ARP
        packet
    Else,
        this ARP packet is accepted.
```

This algorithm protects all machines within a network, which have received their IP addresses via the DHCP protocol, from ARP cache poisoning. An attacker trying to perform an ARP cache poisoning attack will be spoofing the source IP address in the ARP packet with the victim's IP address and the source MAC address with the attacker's own MAC address. If the victim has received the IP address via the DHCP protocol, the IP address to MAC address mapping of the victim machine would be in the DHCP mapping table or the dhcp.leases file. When the ARP patrol agent receives the spoofed ARP packet from the attacker, the attack is immediately detected and packet is dropped.

4. IMPLEMENTATION

This section explains how the design described above was implemented in a real world wireless Access Point. It first describes the choices available in hardware and the one that was chosen for this project. This section also describes in detail the 'open source firmware' that was chosen to be uploaded into the hardware in order to make the modifications.

4.1 Hardware

The choice of hardware was based on which manufacturers were providing source code for their firmware. The two open source wireless Access Points that I explored were EW-7209APg manufactured by Edimax and WRT54GL manufactured by Linksys.

4.1.1 EW7209APg by Edimax

The EW7209APg is a wireless Access Point that complies with the IEEE 802.11b/g 2.4 GHz specification along with a built-in 5-port 10/100 M switch. The hardware also provides a DHCP server within it. One of the advantages of this hardware is that the firmware is upgradeable via a web server. The problem encountered with this hardware was that all the necessary tools and other support needed for correctly building the source code were not available. The build scripts were not complete and this resulted in the developer-compiled firmware not being usable to upgrade the hardware.

4.1.2 WRT54GL by Linksys

WRT54GL is a Wi-Fi enabled router manufactured by Linksys, through which wireless and wired clients can share an Internet connection using the 802.3 Ethernet and 802.11b/g data link layers. WRT54GL combines the functionality of an Ethernet switch, wireless access point and a router. The wireless access point serves wireless clients and the Ethernet switch connects the wired clients. The router connects all of the wired and wireless clients via a DSL connection or a high-speed cable to the Internet. The wireless router also acts as a DHCP server to all the clients connected to the wireless access point and the Ethernet switch.



Figure 19: WRT54GL wireless router

Specifications and Hardware Inside of WRT54GL:

CPU speed	: 200 MHz
RAM	: 16 MB
Flash memory	: 4 MB
System-On-Chip	: Broadcom 5352EKPB
Wireless	: Integrated Broadcom BCM2050KML
Switch	: Built-in

The WRT54GL has the Linux operating system running in it. Hence under the obligations of the GNU General Public License (GPL) Linksys has released the firmware source code. One of the advantages of having the Linux OS running in the hardware is that developers can open a telnet session to the hardware and make modifications by running a shell within the hardware itself. The packages compatible for the Linux OS can be downloaded and added to the hardware, facilitating development work on the WRT54GL. Various development projects have been done on the WRT54GL's original firmware source code resulting in many third party open source firmware code bases. Some of the third party open source firmware code bases are:

- DDWrt – DDWrt is a third party firmware developed from the existing Linux source code in the WRT54GL Linksys router. The firmware adds more features to the original router code. This firmware is mainly used for increasing the functionality of the router and customizing it. It is not intended for open source development although the source code is available.
- OpenWrt – OpenWrt is a third party firmware developed from scratch using the stock firmware of the WRT54GL wireless router. It is intended for developers to be able to add features and publish them to the OpenWrt community of developers.

4.2 OpenWrt Firmware

For this project I chose OpenWrt.

4.2.1 About OpenWrt

OpenWrt is a Linux distribution, which has its own writable file system and package management system [6]. It contains more than 100 software packages and provides facilities in the source code to include more add-on packages. The OpenWrt source code is oriented towards developers by providing a build system, which enables developers to modify the firmware by changing the source code.

4.2.2 Compiling source code for embedded systems

Source code for embedded systems cannot be compiled within the embedded system itself. Embedded systems have lower processing power and memory; hence it is not possible to run a compiler directly on an embedded system. Instead, we need to have a cross compiler on our development machine that will compile the firmware and produce the binary for our embedded system.

4.2.3 Building OpenWrt image

OpenWrt's build script has been made easy for developers to download the source code and build the firmware image [6]. OpenWrt's Makefiles are written in

such a way that they will download the sources, apply necessary patches to work with the given platform and compile the source code for the given platform. The developer does not need to download the appropriate cross-compiler or the patches for the kernel or any other packages necessary for the source code to be compiled since the Makefiles will do it automatically if necessary.

One of the challenges I faced was to understand the design and implementation details of the source code. In addition to the Linux kernel, there are also several packages/modules specific to the router and the OpenWrt distribution. There's very little, if any, documentation on the design and code details. It was also necessary to understand how the Makefiles are structured in OpenWrt, so that upon making changes to parts of the source code tree, those parts would actually get built with the changes and not get regenerated from the original source.

4.3 Code placement

One of the coding-level challenges in this project was to find the appropriate location to hook the `arp_patrol_agent()` code. As the DHCP server was already in the system, I followed the 'Design using `dhcp.leases` file' approach, thus not needing to implement the `dhcp_agent()` in this hardware. The `arp_patrol_agent()` needed to be placed in such a location where I could monitor packets irrespective of whether they are sent by a wireless client or a wired client.

There exists a framework called Netfilter for doing packet filtering/mangling at the kernel level. Different layers in the network stack provide network hooks. Hooks are specific locations in the code to which software can register itself. Kernel modules that want to mangle packets should register with these netfilter hooks. Whenever the code reaches the netfilter hooks, the kernel modules that have registered with these hooks will be invoked.

As shown in Fig 20, in the OpenWrt firmware, the wired Ethernet interface (`vlan0`) and the wireless interface (`eth1`) are connected by a bridge, represented

by the br0 interface. A packet being transmitted from the Ethernet interface to the wireless interface or vice-versa is forwarded by the bridge.

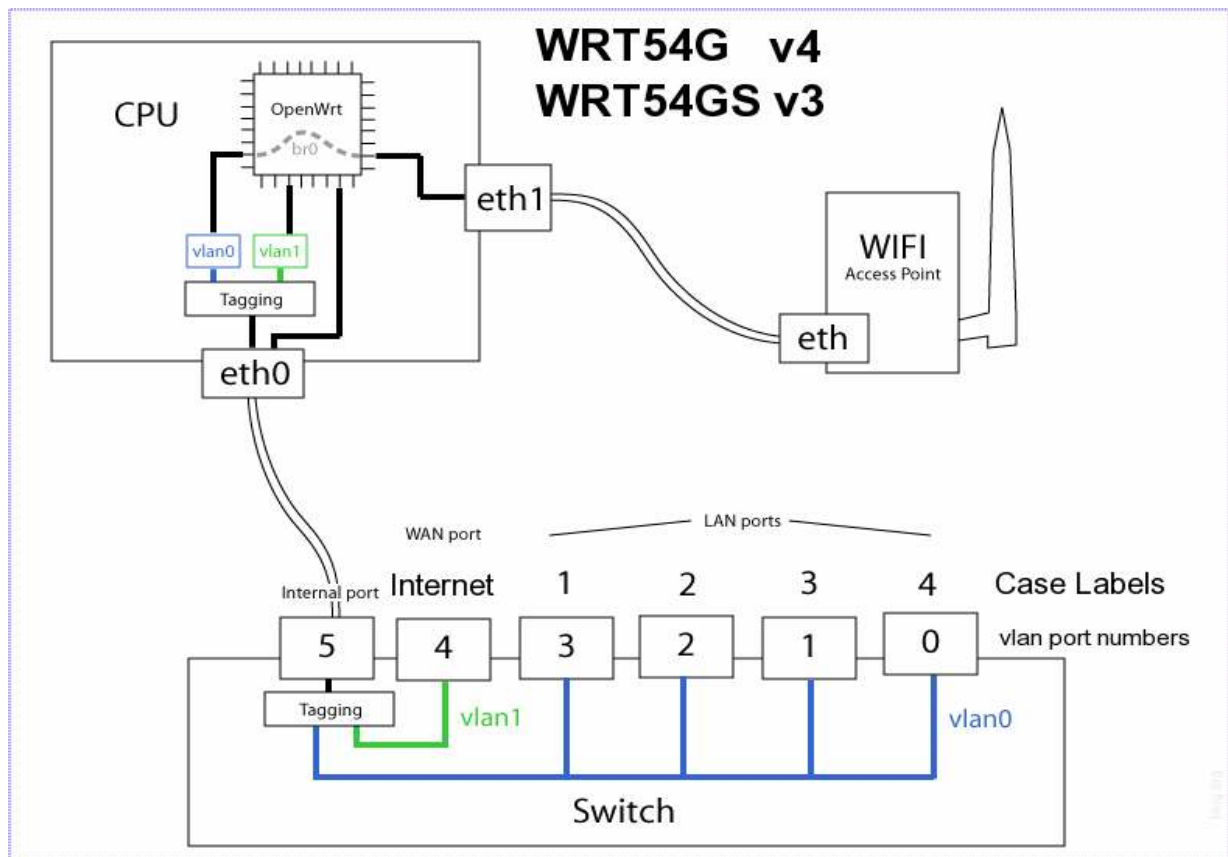

Figure 20: Internal diagram of the OpenWrt firmware [6]

The Ethernet bridging code of the OpenWrt firmware has defined six netfilter hooks. The main hooks are the INPUT, FORWARD and OUTPUT hooks. The INPUT hook is located at the point where the bridge has decided that the packet is destined for the local computer. The FORWARD hook is located at the point where the bridge has decided that the packets are to be forwarded to the other side of the bridge. The OUTPUT hook is located at the point where the bridging decision has been made for packets that originated in the router. A kernel module called Ebtables is registered with these netfilter hooks. Ebtables [12] refers to Ethernet bridging tables and can be used to parse the Layer 2 header of the packets passing via the bridge. Every packet that passes via the bridge from

one Layer 2 interface to another Layer 2 interface has to pass through the netfilter FORWARD hook, which will invoke the ebtables module. This parsing of packets by Ebtables is not done by default. As part of my implementation, I force the Ebtables module to parse the Layer 2 header of every packet passing via the bridge. When an ARP packet is detected, Ebtables invokes the `ebt_arp_filter()` function. In this function I have added my `arp_patrol_agent()` hook. The `arp_patrol_agent` detects the occurrence of an ARP poisoning attack. Depending on the verdict from the `arp_patrol_agent()` the `ebt_arp_filter()` function is asked to DROP or ACCEPT the packet .

4.4 Implementation details

This section describes the implementation details of the various components of the system.

4.4.1 dhcp.leases file

The DHCP server in the router assigns IP addresses to wireless clients and wired clients that are connected to the router. For every IP address assigned the server stores the IP address and the MAC address of the machine to which the IP address is assigned, in a `dhcp.leases` file. The fully qualified path of the file in this firmware is `/tmp/dhcp.leases`

Format of the dhcp.leases file:

```
946689575 00:00:00:00:00:05 192.168.1.155 wdt 01:00:00:00:00:05
946689522 00:00:00:00:00:04 192.168.1.237 * 01:00:00:00:00:04
946689351 00:0f:b0:3a:b5:0b 192.168.1.208 colinux *
946689493 02:0f:b0:3a:b5:0b 192.168.1.199 * 01:02:0f:b0:3a:b5:0b
```

The first column is the time of lease expiry in epoch time (seconds since 1970), the second column is the MAC address, the third column is the assigned IP address, the fourth column is the host name and the fifth column is the client-id usually derived from the client's MAC address. The `dhcp.leases` file is updated

every time an IP address is assigned newly or when a client renews the lease time for a previously assigned IP address. The entry is removed when the lease expires. Hence the dhcp.leases file is always up to date.

4.4.2 arp_patrol_agent()

```
static int arp_patrol_agent(const sk_buff *skb)
```

Parameters: sk_buff *skb

Returns: 0 if there is a poisoning attack detected and 1 if there is no attackdetected

sk_buff - It is the packet structure used in the Linux Operating system to transfer a network packet between the different layers of the network stack.

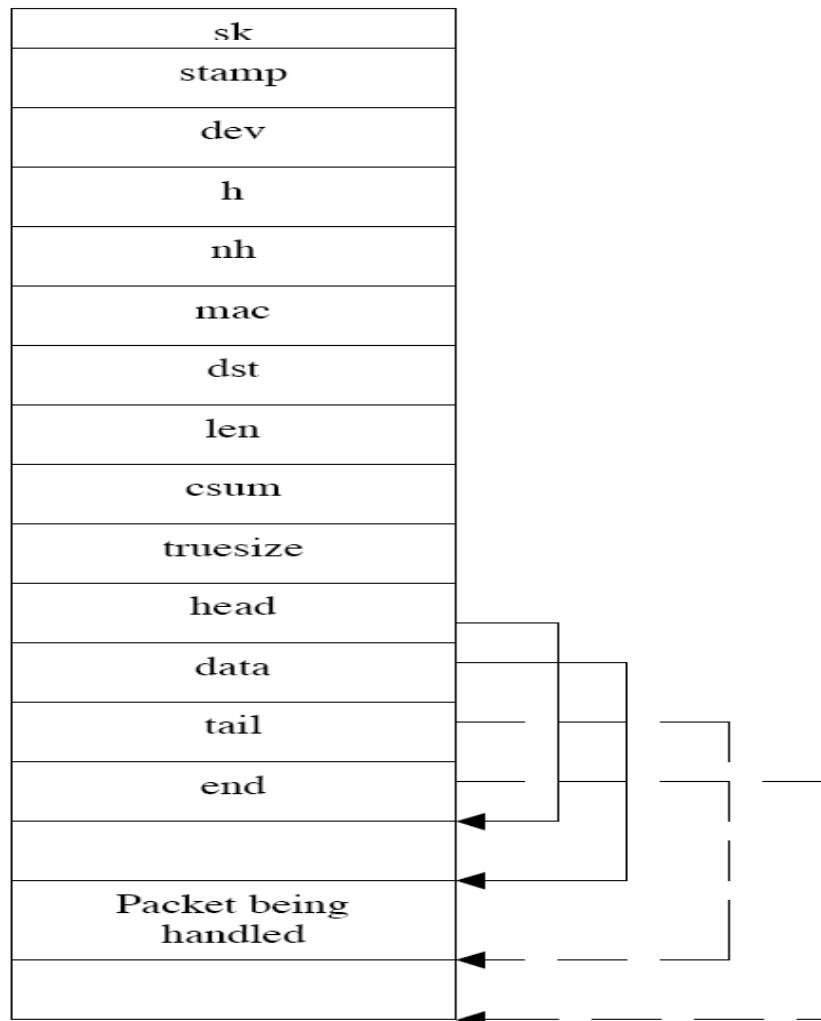

Figure 21: Structure of sk_buff

Once a packet is received at the physical layer, which is the NIC, the device driver creates an `sk_buff` structure and populates it with IP data [11]. The device driver then calls the function `netif_rx()` to pass the `sk_buff` structure to the upper layer protocols.

Description of the important fields follows:

sk: pointer to the socket owning this packet

stamp: time this packet arrived

h: transport layer header pointer

nh: network layer header

mac: pointer to link layer header

len: actual data length

next: pointer to the next `sk_buff`{}

prev: pointer to the previous `sk_buff`{}

dev: dev currently being used

data: pointer to the start of data.

tail: pointer to end of protocol data.

end: pointer to end of the buffer holding

The `sk_buff` structure has a pointer `nh`, to the network layer header; in the case of an ARP packet the network layer header is the ARP header. From the ARP header, the function will read the source IP address and check if that IP address exists in the `dhcp.leases` file. If so, the function will retrieve the source MAC address from the `sk_buff` structure and compare it with the one in the `dhcp.leases` file, corresponding to the source IP address. If the mapping in the packet is not the same as the mapping in the `dhcp.leases` file a value of 0 is returned, else a value of 1 is returned. If the IP address in the `sk_buff` structure does not exist in the `dhcp.leases` file, a value of 1 is returned.

4.4.3 Boot script changes

The kernel module, Ebttables, into which I hooked my `arp_patrol_agent`, does not get loaded into the kernel by default at boot time. The user can start an ssh or a telnet session with the router and type `insmod` (insert module) on the command line to get Ebttables and other related modules to be loaded. In order to automate the process of ARP cache poisoning detection, I've modified an OpenWrt boot script to insert the necessary modules at boot time.

When the OpenWrt distribution of the Linux Operating system boots up, it runs all the boot scripts starting with the letter 'S' in the `/etc/init.d` directory. The daemons and background processes that need to be run when the system is booting up are included in these scripts. One such boot script is the 'S10boot' script. I have added the commands to insert the modules `ebttables`, `ebt_arp` and `ebtable_filter` in this boot script.

4.4.4 Limitation of this implementation

The WRT54GL router uses a Broadcom chipset in its wireless Access Point. Broadcom does not release the device driver source code that handles the transmission of packets from one wireless client to another wireless client. The `arp_patrol_agent()` needs only to be hooked into the device driver code for the ARP cache poisoning attack to be prevented from one wireless client to another wireless client. But since the source code is not available, the agent has currently not been hooked into the driver.

5. TEST CASES AND RESULTS

This section describes the various tests done to poison a host's ARP cache, emulating various attack scenarios as described in Section 2.4.1. The tests were conducted on a combined home gateway, the Linksys WRT54GL wireless router. The results show what the ARP cache contains before and after the `arp_patrol_agent()` was added. In addition to the Linksys WRT54GL wireless router, the test environment contained a Pentium III desktop with 512 MB RAM

running Windows 2000, connected to the 10/100 M switch of the wireless router using an Ethernet cable. A Dell Latitude D620 laptop having 1.83 GHz CPU speed with 1.99 Gb RAM running Fedora Linux and a Dell Inspiron 1000 laptop with 2.19 GHz, 44MB RAM, running Windows XP Home Edition, both equipped with a Wireless NIC card and an Ethernet NIC card, were interchangeably connected to the wireless router as wired or wireless clients as required by the attack scenario.

5.1 Attack scenarios tested

5.1.1 Attacking wired clients using a wireless client

The setup of the LAN for this attack scenario is as shown in Fig 24. Host A and Host B are wired clients connected to the 10/100 M switch of the wireless router and the Attacker is a wireless client connected to the Access Point in the wireless router.

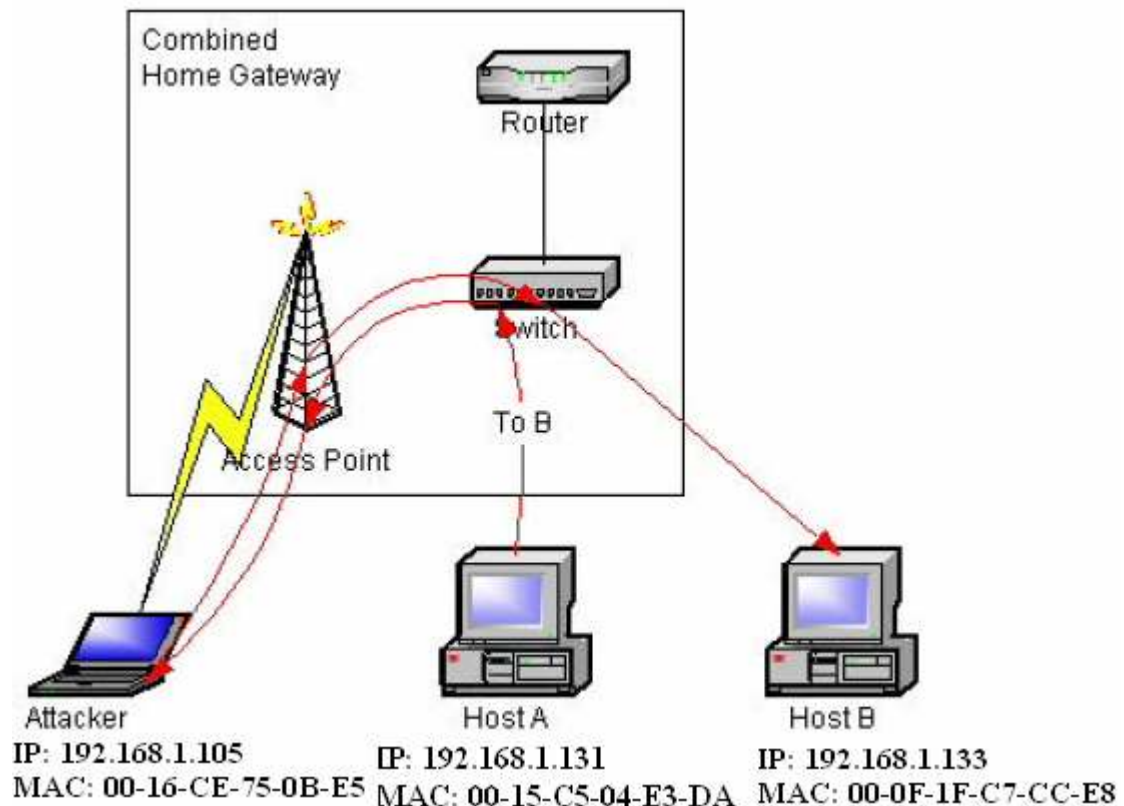
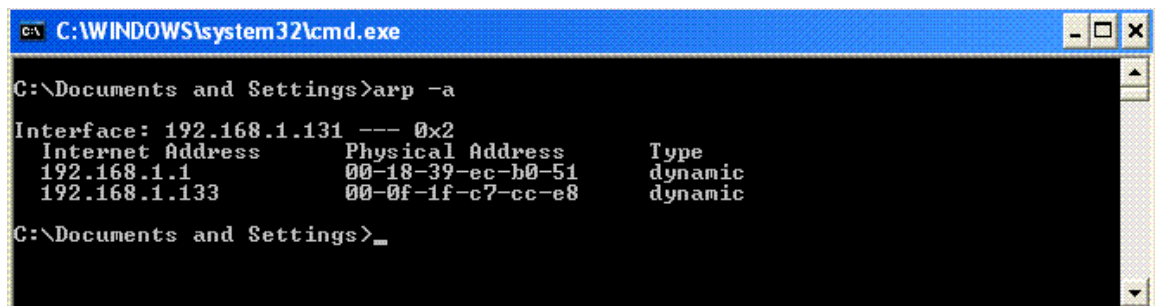

Figure 22: Attacking wired clients from wireless client

Host A and Host B want to communicate with each other. The Attacker wants to divert the communication between Host A and Host B to flow through the Attacker. The IP address and MAC address of each machine areas indicated in the Figure 22.

Before the attack:-

Host A's arp cache after communicating with Host B is as follows:



```

C:\WINDOWS\system32\cmd.exe
C:\Documents and Settings>arp -a
Interface: 192.168.1.131 --- 0x2
  Internet Address      Physical Address      Type
  192.168.1.1          00-18-39-ec-b0-51    dynamic
  192.168.1.133       00-0f-1f-c7-cc-e8    dynamic
C:\Documents and Settings>_

```

Figure 23: ARP cache of Host A before the attack

Host B's arp cache after communicating with Host A is as follows:

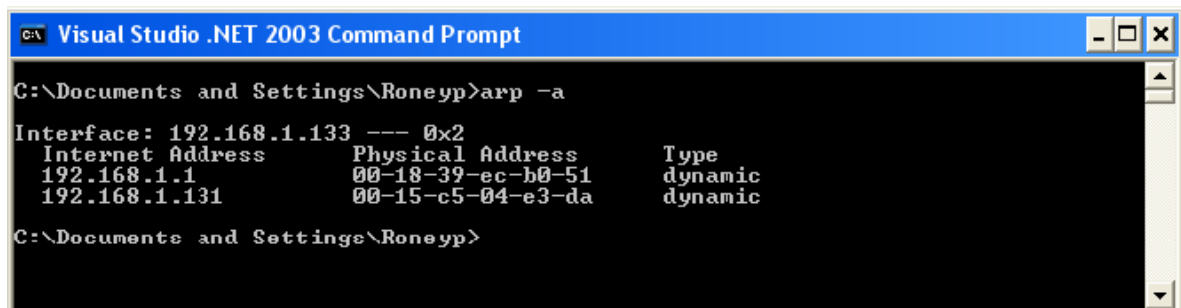

```

C:\ Visual Studio .NET 2003 Command Prompt
C:\Documents and Settings\Roney>arp -a
Interface: 192.168.1.133 --- 0x2
  Internet Address      Physical Address      Type
  192.168.1.1          00-18-39-ec-b0-51    dynamic
  192.168.1.131       00-15-c5-04-e3-da    dynamic
C:\Documents and Settings\Roney>

```

Figure 24: ARP cache of Host B before the attack

Demonstration of the attack:

To perform an ARP cache poisoning attack the Attacker sends a spoofed ARP reply to Host A with Host B's IP address as the source IP address and the Attacker's MAC address as the source MAC address. Similarly the Attacker sends a spoofed ARP reply packet to Host B with Host A's IP address as the source IP address and the Attacker's MAC address as the source MAC address.

After the attack:-

Host A's arp cache:

```

C:\WINDOWS\system32\cmd.exe
C:\Documents and Settings>arp -a
Interface: 192.168.1.131 --- 0x2
  Internet Address      Physical Address      Type
  192.168.1.1           00-18-39-ec-b0-51    dynamic
  192.168.1.133        00-16-ce-75-0b-e5    dynamic
C:\Documents and Settings>

```

Figure 25: ARP cache of Host A after the attack

Host B's arp cache:

```

Visual Studio .NET 2003 Command Prompt
C:\Documents and Settings\Roney>arp -a
Interface: 192.168.1.133 --- 0x2
  Internet Address      Physical Address      Type
  192.168.1.1           00-18-39-ec-b0-51    dynamic
  192.168.1.131        00-16-ce-75-0b-e5    dynamic
C:\Documents and Settings\Roney>

```

Figure 26: ARP cache of Host B after the attack

ARP Cache Poisoning prevention with arp_patrol_agent() :-

With my design when the Attacker sends a spoofed ARP packet to Hosts A and B, the packet travels through the Ethernet Bridge to reach the wired clients. In the bridge the *arp_patrol_agent()* checks if the source IP address and the source MAC address mapping in the ARP packet is the same as the mapping in the dhcp.leases file. Since the mappings are not same the ARP packet is dropped and hence the packets do not reach Hosts A and B.

After performing the attack: -

Host A's ARP cache:

```

C:\WINDOWS\system32\cmd.exe
C:\Documents and Settings>arp -a
Interface: 192.168.1.131 --- 0x2
  Internet Address      Physical Address      Type
  192.168.1.1          00-18-39-ec-b0-51    dynamic
  192.168.1.133       00-0f-1f-c7-cc-e8    dynamic
C:\Documents and Settings>_

```

Figure 27: ARP cache of Host A when arp_patrol_agent() is enabled

Host B's arp cache:

```

Visual Studio .NET 2003 Command Prompt
C:\Documents and Settings\Roney>arp -a
Interface: 192.168.1.133 --- 0x2
  Internet Address      Physical Address      Type
  192.168.1.1          00-18-39-ec-b0-51    dynamic
  192.168.1.131       00-15-c5-04-e3-da    dynamic
C:\Documents and Settings\Roney>

```

Figure 28: ARP cache of Host B when arp_patrol_agent() is enabled

5.1.2 Attacking a wireless client and a wired client

In this scenario, the setup of the LAN is as shown in Fig 29. Host B is a wired client connected to the 10/100 M switch of the wireless router and the Attacker is a wireless client connected to the Access Point in the wireless router.

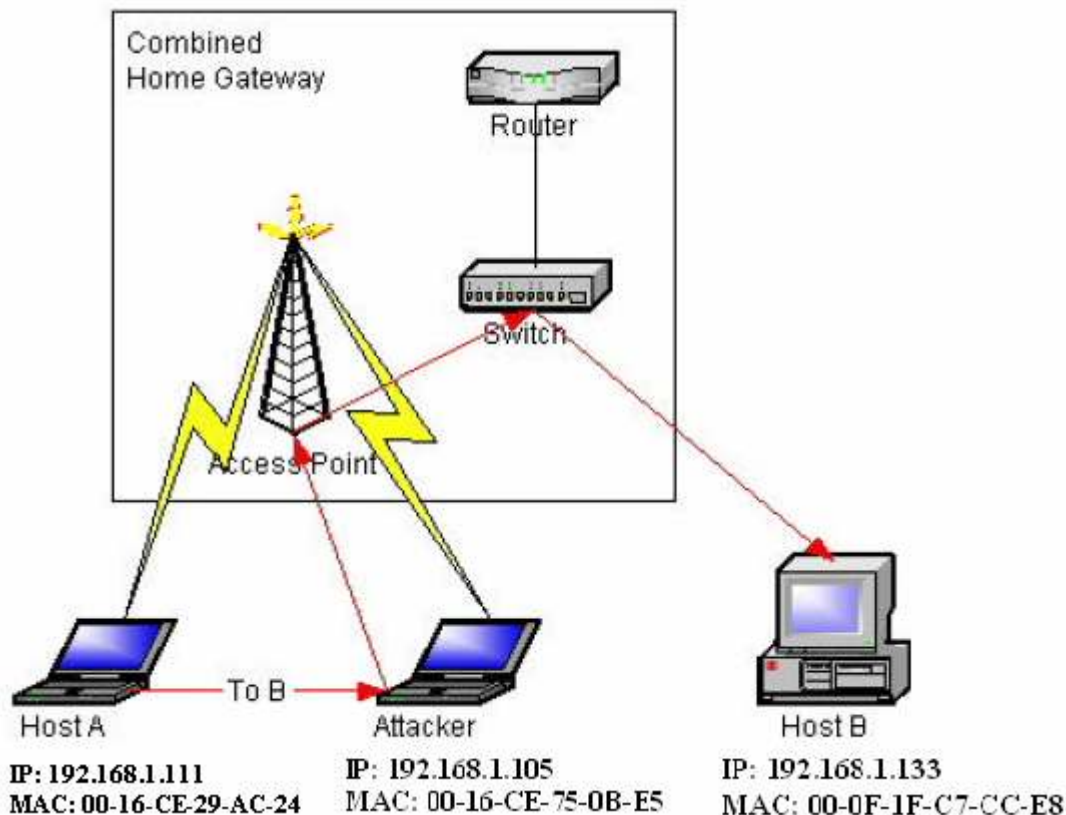

Figure 29: Attacking a wireless and a wired client

Before the attack:-

Host B's ARP cache after communicating with Host A is as follows:

```

C:\WINDOWS\system32\cmd.exe
C:\Documents and Settings>arp -a

Interface: 192.168.1.133 --- 0x2
Internet Address      Physical Address      Type
192.168.1.1          00-18-39-ec-b0-51    dynamic
192.168.1.111       00-16-ce-29-ac-24    dynamic
C:\Documents and Settings>

```

Figure 30: ARP cache of Host B before the attack

Demonstration of the attack:

The Attacker is a wireless client over here and sends a spoofed ARP packet to Hosts A and B as before.

After the attack:-

Host B's arp cache:

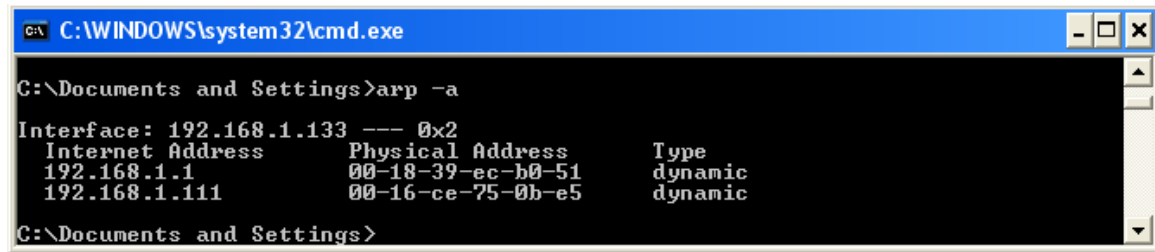

```

C:\WINDOWS\system32\cmd.exe
C:\Documents and Settings>arp -a
Interface: 192.168.1.133 --- 0x2
  Internet Address      Physical Address      Type
  192.168.1.1          00-18-39-ec-b0-51    dynamic
  192.168.1.111        00-16-ce-75-0b-e5    dynamic
C:\Documents and Settings>

```

Figure 31: ARP cache of Host B after the attack

ARP Cache Poisoning prevention with the arp_patrol_agent():-

The Attacker's spoofed ARP packet travels over the Ethernet bridge to reach the wired Host B. The ARP packet is dropped by the *arp_patrol_agent()* on detecting a wrong mapping of IP address and MAC address. Thus the Attacker is not successful in doing a Man-in-the-middle attack as he cannot poison the ARP cache of the wired Host B, disabling him from diverting the traffic between the Host A and Host B.

After the attack:-

Host B's arp cache:

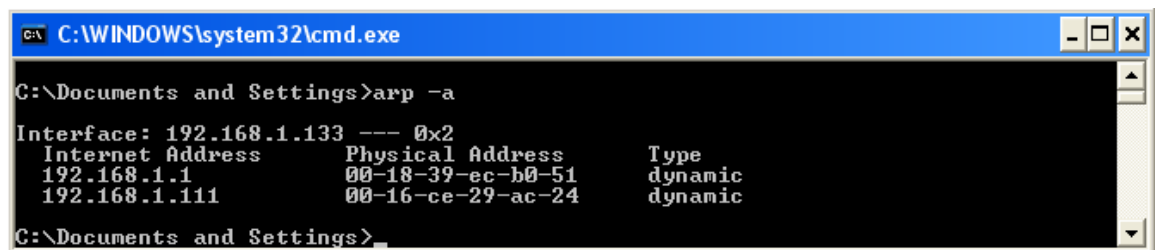

```

C:\WINDOWS\system32\cmd.exe
C:\Documents and Settings>arp -a
Interface: 192.168.1.133 --- 0x2
  Internet Address      Physical Address      Type
  192.168.1.1          00-18-39-ec-b0-51    dynamic
  192.168.1.111        00-16-ce-29-ac-24    dynamic
C:\Documents and Settings>

```

Figure 32: ARP cache of Host B when arp_patrol_agent is enabled

5.2 Impact on Performance

I have studied the impact on performance that the *arp_patrol_agent* will introduce to the ARP protocol. I tested the round trip time (RTT), from when an ARP request is sent to when a corresponding ARP reply is received. The RTT was measured when the router is running the *arp_patrol_agent* as well as when the router is not running the *arp_patrol_agent*.

The performance test was done by sending 1000 pings (ICMP echo requests) from a host A to a host B. The ping causes the host A to issue an ARP request to B and receive an ARP reply from B. After each ping command the ARP cache of A was cleared. From an Ethereal trace running in A, we were able to measure the RTT of an ARP request-reply pair.

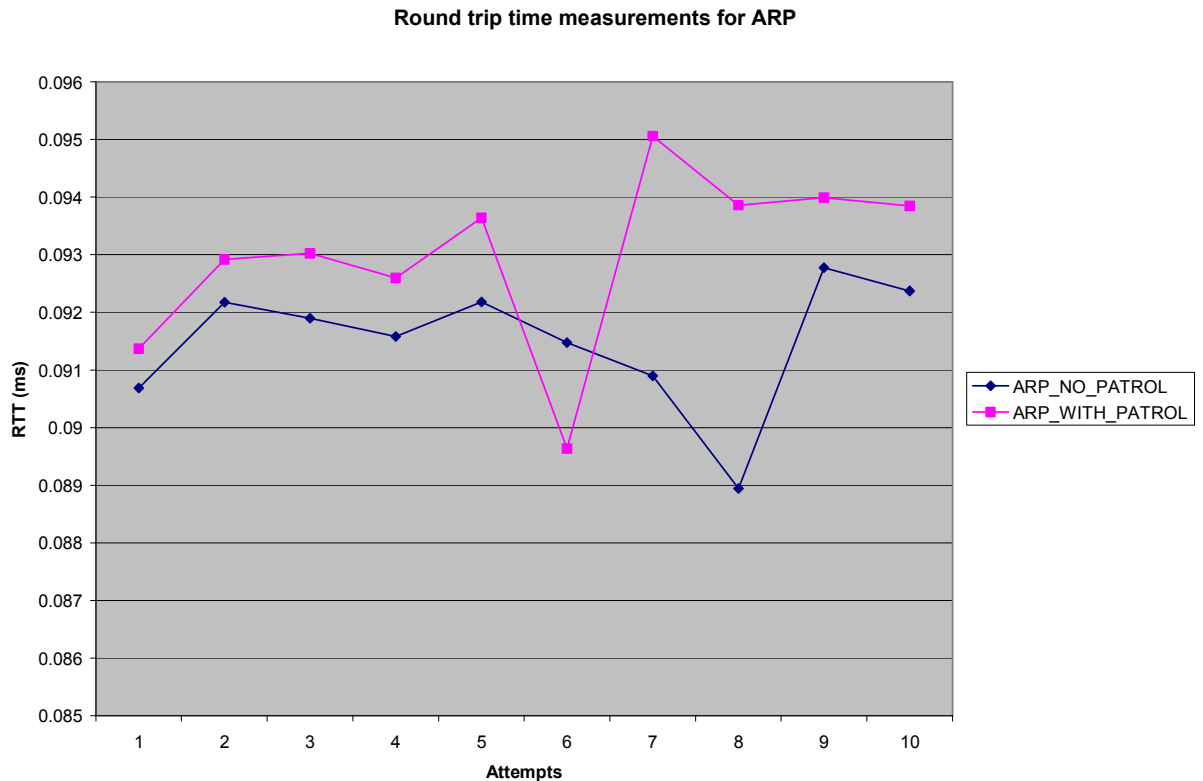

Figure 33: Round trip time measurement for ARP request-reply in ms

I have plotted a graph of 10 points where each point represents the average of the RTT of 100 ARP request-reply pairs. The averaging was done because, as can be expected, there is a lot of variance in the RTT. As we see from the graph in Figure 33, the increase in RTT of ARP when the `arp_patrol_agent` is running is almost negligible. I have also plotted another graph, Figure 34, which shows the percentage increase or decrease in the RTT of ARP when the `arp_patrol_agent` is running. From the above tests I have observed that the average performance degradation when the `arp_patrol_agent` is running is approximately 1.65%. Also, as exemplified by the sixth point, the variance in RTT due to extraneous factors,

like load on the hosts, even causes the RTT with `arp_patrol_agent` to be less than RTT without the agent. This suggests that the minor degradation in performance observed here could be statistically insignificant.

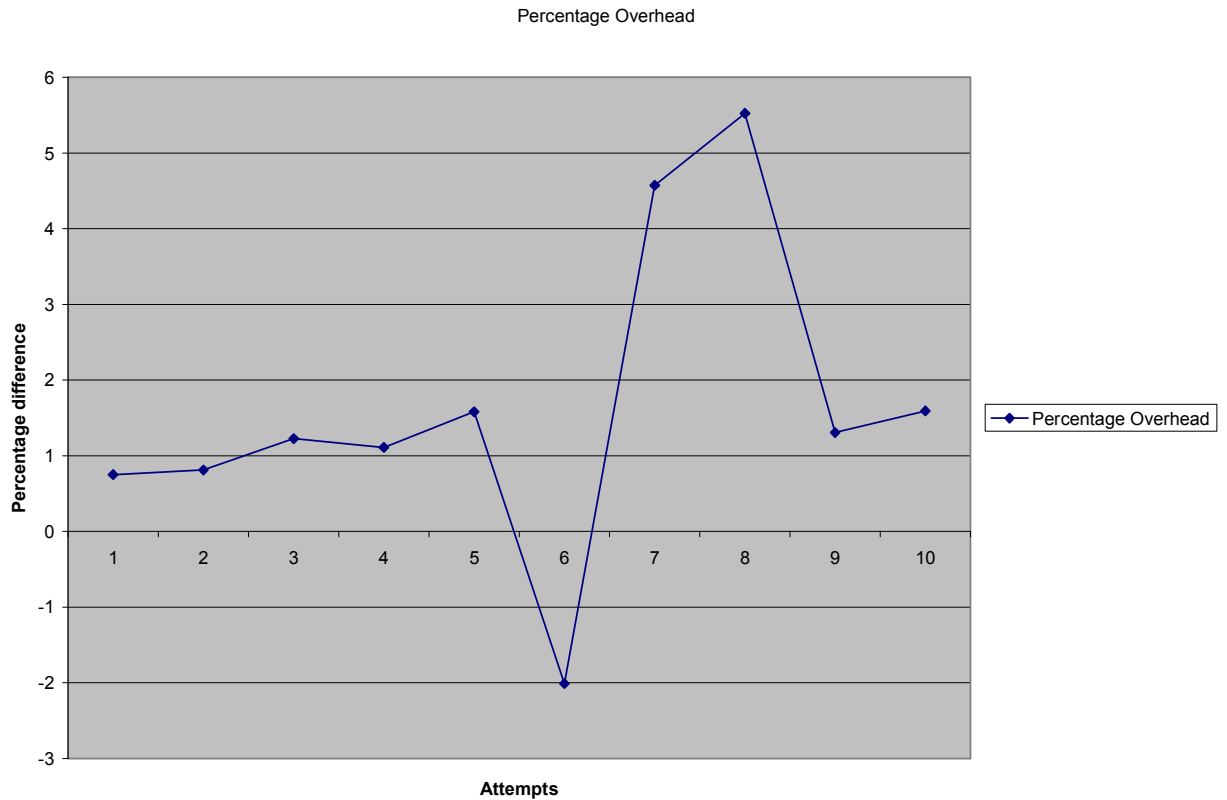

Figure 34: Percentage overhead

6. CONCLUSIONS AND FUTURE WORK

In this report I have described the problem of ARP cache poisoning in wireless networks. I have shown how the inherently secure wired clients are vulnerable to an attack from the wireless clients due to the nature of the setup of wireless-cum-wired networks within network devices like wireless access points or wireless routers. I have proposed a scheme to prevent the ARP cache poisoning attack from within these network devices.

The proposed scheme is a feasible approach for preventing ARP cache poisoning, as it does not require any modification to the ARP protocol itself. Any

modification to the ARP protocol would require the TCP/IP stack of all the hosts that need protection to be changed.

The scheme also does not add any significant overhead while sending and while receiving an ARP packet. The checking of the ARP packet is only done once in the Access Point and not at both the sending and receiving sides.

As a proof of concept I have implemented the scheme in a popular wireless router, the WRT54GL manufactured by Linksys. The scheme protects any client that has received an IP address from a DHCP server from ARP cache poisoning. I have also explained the performance studies conducted and shown that there is negligible impact on the performance of the ARP protocol when my solution is implemented within the wireless router.

The proposed scheme opens up various possibilities for enhancement. Some of the possibilities are described below:

- The above design does not support hosts that have static IP addresses. When a wireless client wants to join a wireless network, it has to first associate with the Access Point. The Access Point at this time can learn the static IP address to MAC address mapping of the wireless client and store it in the mapping table.
- The `arp_patrol_agent` code has been implemented currently to fit to the needs of the OpenWRT firmware installed in the Linksys wireless router. The code could be written such that it is more portable irrespective of the platform it has to operate on.
- Reading from the `dhcp.leases` file could be done faster by storing the IP addresses once seen in a hash table along with their corresponding MAC addresses. When an ARP packet is received, if the IP address to MAC address mapping in the packet exists in the hash table then accept the packet; else check for the mapping in the `dhcp.leases` file.

REFERENCES

- [1] Fleck, B., Dimov, J., Wireless Access Points and ARP Poisoning: Wireless vulnerabilities that expose the wired network.
www.eecs.umich.edu/~aparakash/eecs588/handouts/arppoison.pdf

- [2] Issac, B.; Mohammed, L.A. (2005), Secure unicast address resolution protocol (S-UARP) by extending DHCP, *13th IEEE International Conference on Networks*

- [3] Whalen, S.,(2001) An Introduction to ARP Spoofing
www.node99.org/projects/arpspoof/arpspoof.pdf

- [4] A Survey of 802.11 a Wireless Security Threats and Security Mechanisms
www.itsec.gov.cn/webportal/download/75.pdf

- [5] DHCP – Another Untrustworthy Service
<http://www.spirit.com/Network/net0202.html>

- [6] OpenWrt Docs
<http://wiki.openwrt.org/>

- [7] Droms, R. Dynamic Host Configuration Protocol, RFC2131

- [8] Arbaugh , W.A., Shankar, N., Wan, Y.C.J., (2001) Your 802.11 Wireless Network has No Clothes.

- [9] Brushi, D., Ornaghi, A., Rosti, E. (2003), S-ARP: A Secure Address Resolution Protocol, *Proceedings of the 19th Annual Computer Security Applications Conference.*

- [10] Tripunithara, M.V., Dutta, P. (1999). A Middleware Approach to Asynchronous and Backward Compatible Detection and Prevention of ARP Cache Poisoning, *15th Annual Computer Security Applications Conference (ACSAC '99)*, 303.
- [11] A Map of the Networking Code in the Linux Kernel 2.4.20
<http://datatag.web.cern.ch/datatag/papers/tr-datataq-2004-1.pdf>
- [12] Ebtables/iptables interaction on a Linux-based bridge
http://ebtables.sourceforge.net/br_fw_ia/br_fw_ia.html
- [13] Stevens, R. W. *TCP/IP Illustrated, Volume 1: The Protocols. Addison–Wesley Professional Computing Series*, January 1994.
- [14] Gast, M. *802.11 Wireless Networks: The Definitive Guide*. O'Reilly publishing, April 2002
- [15] Strebe, M. and Perkins, C. TCP/IP from a security viewpoint, *Microsoft TechNet*
<http://www.microsoft.com/technet/archive/winntas/maintain/tcpip.msp?mfr=true>
- [16] Network Bridge
http://en.wikipedia.org/wiki/Network_bridge